

Ground Control Solutions





**RELIABLE
GROUND
SUPPORT**

Introduction4

Research & Development8

DYWI® Drill Hollow Bar System 14

Passive Support60

Rock Reinforcement.....96

Pre-Support.....144

Drainage and Injection..... 168

Mechanized Tunneling.....188



Introduction

Focus Global Tunneling

DSI Underground is a leading system supplier of innovative technologies with approximately 2,800 employees around the world. Today, we are one of the largest manufacturers and suppliers of technically sophisticated ground control solutions for Tunneling.

To ensure efficient logistical and technical services worldwide, we dispose of a large number of wholly-owned companies and subsidiaries. Our distributing warehouses on all continents offer fast and competent local support to our customers to meet new requirements at all times.

Our experienced and highly motivated experts for Tunneling continuously stay in touch with designers, consultants, contractors, and clients.

**BRIDGING THE GAP BETWEEN
CHALLENGE AND SOLUTION**

Extension of Local Presence in Regional Market Segments

International customers profit from our distributing warehouses built specifically for their needs as well as from our comprehensive services. We are represented in 90 countries worldwide

with wholly-owned DSI Underground subsidiaries, licensees, or agents. We offer an efficient electronic documentation system, software for optimized loading, packaging optimized for exportation

as well as a large variety of logistical solutions that are provided by our customer-oriented export team.

**LOCAL PRESENCE -
GLOBAL COMPETENCE**



Introduction

What does DSI Underground offer its Customers?

All Underground structures are unique. Most ground support challenges encountered during construction are project-specific and require individual solutions. Innovative system solutions are often individually adapted to customer requirements and must quickly be identified and supplied.

DSI Underground's interdisciplinary work groups always maintain close contact with clients in order to create best fitting solutions in our own laboratories. We develop prototypes and carry out intensive on-site tests to provide high quality products and specific system solutions that you as our customers need.

We always guarantee you our full support. Furthermore, we offer a comprehensive training program, the transfer of know-how, and on-site installation supervision.

DELIVERING THE SUPPORT YOU NEED

Key Competence – Service and Customer Support

Ground control stabilization for Underground applications requires that all elements are adequately designed and correctly installed.

Since an efficient stabilization only results from the functioning interaction of all individual elements, testing of ground support products is carried out by the same team that also develops

and produces them. This way, we can guarantee that all components of a system function faultlessly.

DSI – THE SOLUTION PROVIDER



Introduction

Local Presence – Global Competence



Caldecott Tunnel,
Highway 24, Oakland -
Orinda, CA, USA



Drumanard Tunnel,
Louisville, KY, USA



3rd Tunnel Niagara Falls,
ON, Canada



Tysons Corner, Dulles
Corridor Metrorail Project,
Vienna, VA, USA



Hirschhagen Tunnel,
Kassel – Herleshausen,
Germany



Pencaligüe Hydroelectric
Power Plant,
Santa Barbara, Honduras



Loboguerrero Tunnel
Chain, Valle del Cauca,
Colombia



Hindhead Tunnel, A3
Highway, Surrey, UK



Metro Algier, Algeria



Alto Maipo Hydroelectric
Power Plant, Maipo Valley,
Chile



Cheves Hydroelectric
Power Plant, Lima, Peru



Ceneri Base Tunnel,
Ticino, Italy



San Cristóbal Tunnel,
Santiago, Chile



Transolímpica Tunnel,
Rio de Janeiro, Brazil



Thirra-Tunnel, Durrës,
Kosovo – Albania

Introduction



Alaufstiege, Stuttgart, Germany



Valik Tunnel, Prague, Czech Republic



Brenner Base Tunnel, Innsbruck, Austria



Koralm Tunnel, KAT 3, Lavant Valley, Austria



M6 Duna Autópálya Motorway Connection, Budapest, Hungary



Sentvid Tunnel, Ljubljana, Slovenia



Omis Tunnel, National Road D8, Omis, Croatia



Liantang/Heung Yuen Wai L6, Hong Kong, China



Shatin to Central Link (SCL), Hong Kong, China



Metsovo Tunnel, Metsovo, Greece



Upper Yeywa Hydropower Project, Myanmar



Rohtang Tunnel, Himachal Pradesh, India



Gautrain High Speed Train, Johannesburg, South Africa



Parramatta Rail Link Tunnel, Parramatta, NSW, Australia



Boggo Road Busway, Brisbane, QLD, Australia

Research & Development

As leaders in innovation, we have been offering our customers a comprehensive range of technically sophisticated system solutions for decades. We actively promote new technical developments and research projects.

Our extensive research & development efforts result in global patent applications proving our leading market position. State-of-the-art ground control solutions are constantly improved – to your advantage.

Customer specific support and individual adaptations of our products and systems are implemented practice-oriented and just in time by competent and experienced engineers in our technical departments.



Research & Development

All R&D activities related to self-drilling ground control solutions are coordinated from the global competence center in Pasching, Austria. Another center of competence for passive ground support is located in Louisville, KY, USA.

Thanks to the consolidation of its activities, DSI Underground offers a complete range of ground support systems to global markets that is strengthened by technical service and innovative developments.

Every day, our customers profit from the technology transfer that has been made possible by this consolidation.

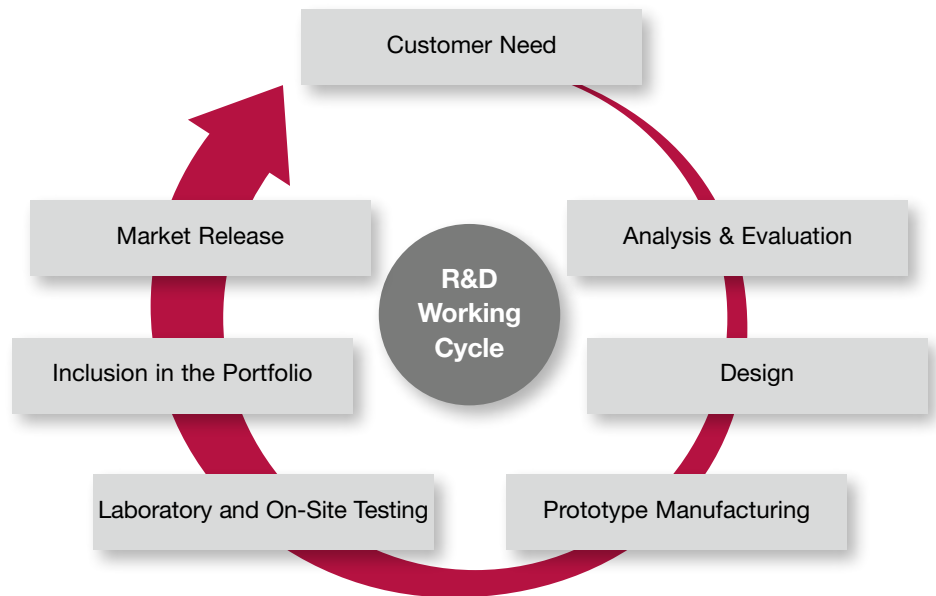

- National and European Technical Approvals
- Self-drilling ground support products: one-step bolts and pre-support systems with immediate load-bearing capacity
- Automation units for different types of ground control systems such as the POWER SET bolt or the AT – Pipe Umbrella Support System
- AT – Pipe Umbrella System: flexible drilling systems and different innovative pipe connections adapted to customer requirements
- LSC™ Element: improved, yielding ground control for excavation in squeezing or swelling ground
- Numerical simulations, laboratory tests, and field examinations
- Knowledge about the interaction between support elements and the ground
- Static calculations for various support structures
- Optimization of steel support designs
- Knowledge transfer to designers and customers in the course of seminars and conferences

Research & Development

Cooperation with Professional Organizations

In order to continue being an innovation leader, we have been maintaining close partnerships and co-operations with leading universities and international expert organizations for decades.

We are always open for new, creative and sometimes unconventional solutions. However, to take that famous extra step,

input from the outside is often required. That is why we are consciously and consistently cultivating an interdisciplinary exchange of experiences across all levels. We are cross-linking specialist knowledge from all kinds of areas and are actively exchanging knowledge with international expert organizations and universities.

We are aware of our responsibility as an innovation leader and are represented in the corresponding committees for experts and standards. This way, we are continuously advancing the technical development as well as the safety and usability of our systems.

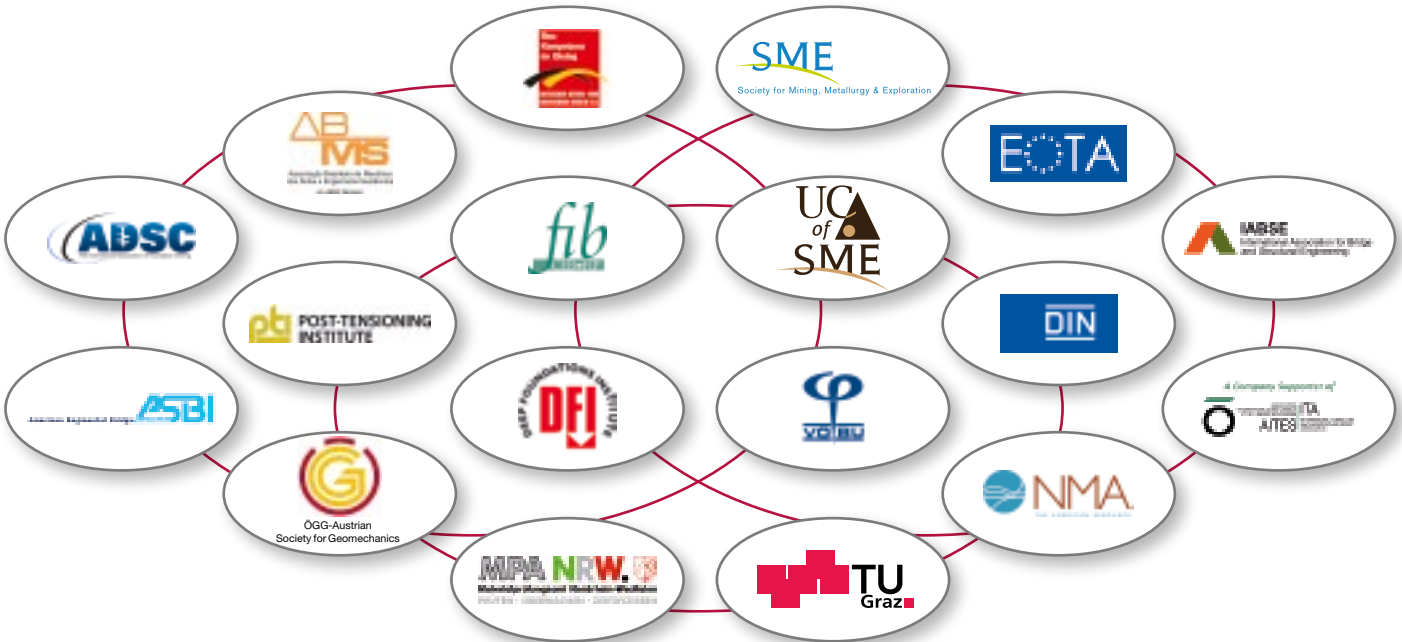

Research & Development

Services and Technical Support

We offer both on-site technical support and product management provided by a team of experienced technicians and skilled service personnel. Our team is at your disposal for general and product specific questions related to the following areas:

- Development and dimensioning of ground control systems
- Testing and evaluation of ground support products
- Self-drilling installation technology
- Design and optimization of lattice girders, steel support, and liner plates
- On-site service for the professional installation and testing of all distributed products and systems

- Realization and supervision of installation and injection works
- Testing of the product specific usage properties of ground support products
- 2-D and 3-D design templates for passive support systems
- Support in all project phases by a team of experienced technicians and licensed professional engineers

In order to actively promote new developments, research projects, and customer requests, we dispose of the following testing, laboratory, and measurement equipment:

- Tensile testing machine with a maximum test load of 4,000 [kN] (900,000 [lbf])
- Universal hardness tester (HRC, HV, HB)
- Surface profile measurement instrument
- Field equipment for anchor tensioning and pull testing
- Utilization of university research institutions and government testing facilities for the evaluation of ground support structures in the pre-construction phase
- Quality control tools for inspection of various types of primary material: flat steel, rebar, and tubes

Quality Assurance

At DSI Underground, quality is our business, and it is at the center of our daily actions. In order to guarantee the implementation of these requirements in all areas from development to application, our sites Pasching in Austria and Louisville in the USA are certified in accordance with ISO 9001. Regular internal and external audits serve to examine and actively promote the development of the quality management system.

Quality is not an aim, but a continuous process, which is also one of the main principles of Total Quality Management (TQM). We are committed to TQM on a global scale and work in accordance with its three basic principles:

- Total
Integration of all employees contributing to the manufacturing of products or systems into the QM process

- Quality
Continuous orientation of all company activities towards customer expectations
- Management
Responsibility and role model function of highest level management based on participative and team oriented leadership

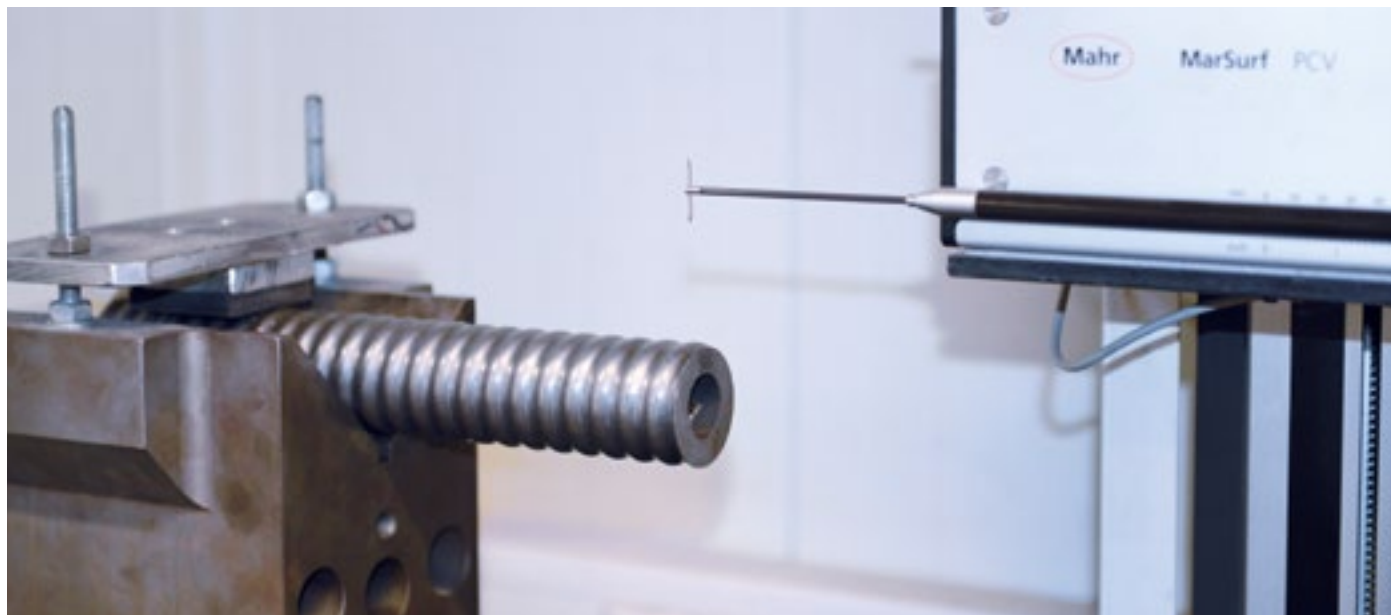





DYWI® Drill Hollow Bar System

Fields of Application

Underground

Face Bolting

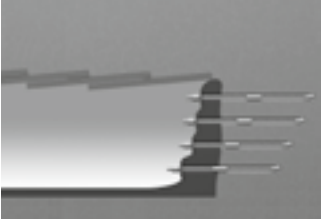

Injection Works

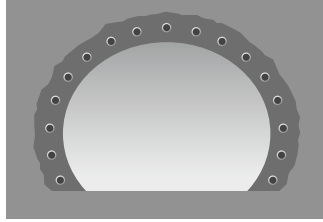

Portal Stabilization



Footwall Stabilization



Roof and Rib Bolting

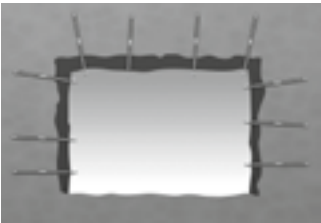

Radial Bolting

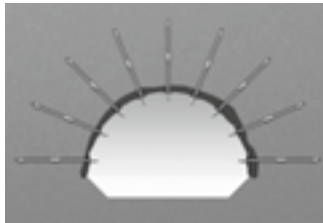

Forepoling

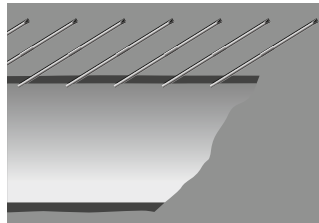

Utility Hangers

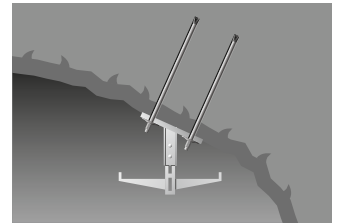

Civil Engineering

Slope Stabilization



Tie Back Anchorage

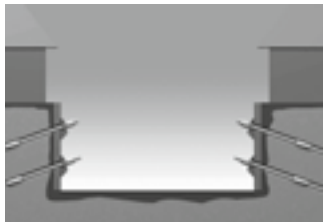

Uplift Control

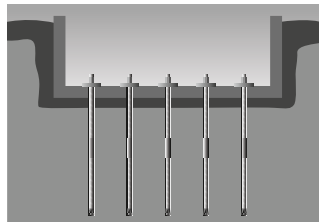

Pile Foundation

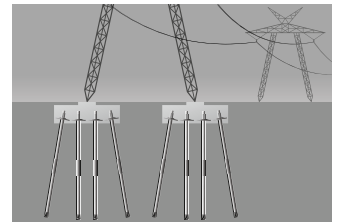

Rock Fall Protection

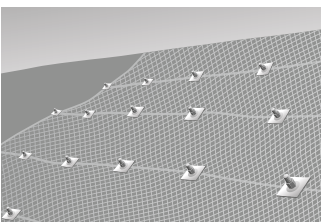

Ground Consolidation

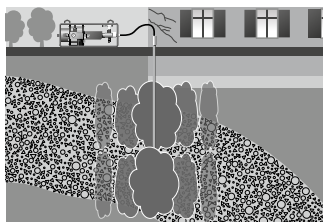

Abutments

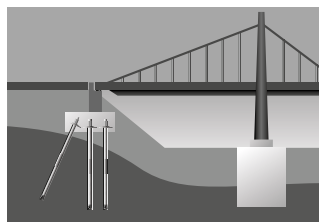

Tie Rods

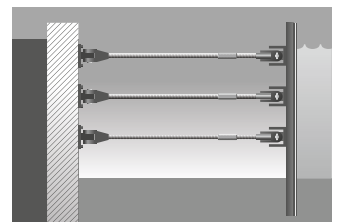

Contents

Introduction	16
Main Advantages	17
System Components	18
Rock and Soil Nail	20
Ground Anchor	22
Micropile	24
Spile and Injection Lance	26
Specifications	28
Corrosion Protection	32
Drill Bits	34
Self-Drilling Installation	36
Testing and Monitoring	39
Further References	41
System Accessories	42
S-D Expansion Bolt	44
Expansion Shell	46
Yielding Anchor Head	47
Lock Coupling	48
Sealing Coupling	49
Post-Injection Coupling	50
Utility Nuts	51
Anchorage Elements	52
Rock Drilling Equipment	54
Injection Adapters	56
Grout Mixing Pump	57
Injection Flow-Pressure Meter	57

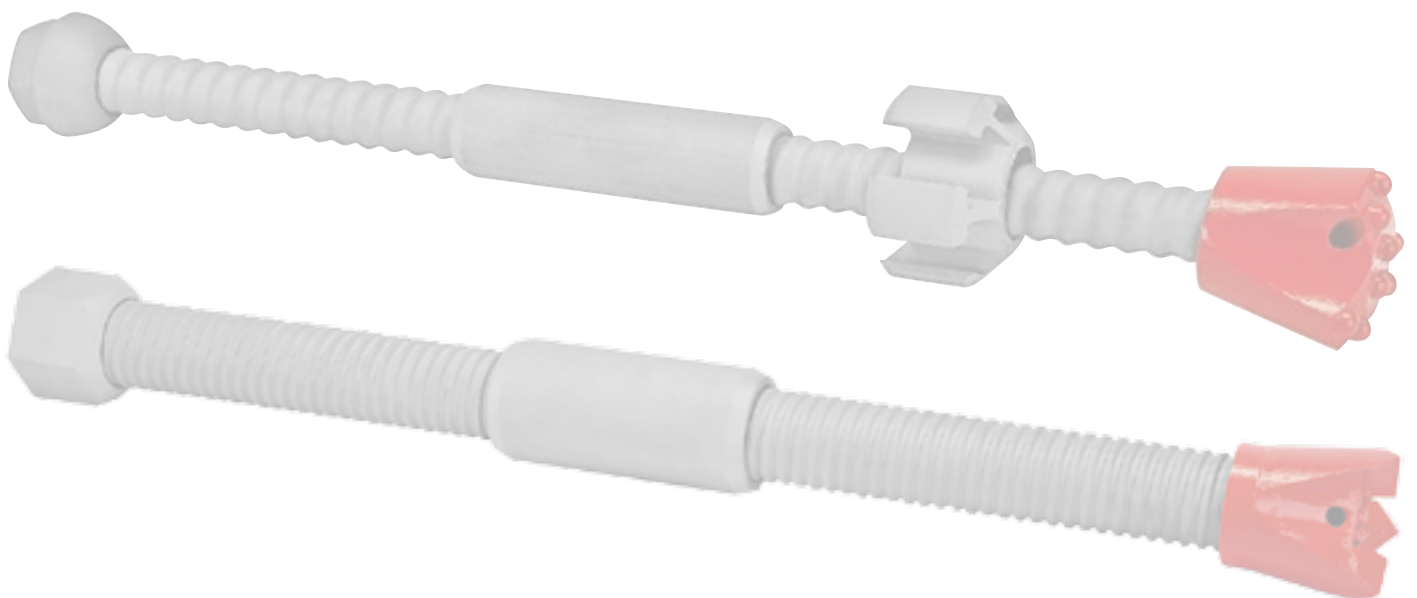

Introduction

The DYWI® Drill Hollow Bar System is a self-drilling ground control solution used for Underground applications and in Civil Engineering. Underground, it can be used for bolting, foot piles, face stabilization, as forepoling element for pre-support, or as a lance for injection works.

The DYWI® Drill Hollow Bar System also features a wide range of applications in Civil Engineering such as rock and soil nails, micropiles, or ground anchors. The system features an “all in one” tool for drilling, flushing, post- or simultaneous grouting, and finally the load-carrying member itself.

Installations in weak ground and unstable borehole conditions represent no difficulty and are ideal for the application of the DYWI® Drill Hollow Bar System. DSI Underground has long-term experience in the design, development, manufacturing, testing, and distribution of the DYWI® Drill Hollow Bar System.

System Solution



System Description

- Self-drilling ground control solution
- Preferably used under unstable borehole conditions
- Self-drilling installation without casing using a lost drill bit
- Installation with standard rotary or rotary-percussive drilling machines
- Hollow bar with continuous left-hand, cold-rolled outside thread utilized as drill rod during installation
- Easy extension of hollow bars using couplings
- Grouting can either be performed during drilling with a rotary injection adapter or after the drilling operation
- Threaded profile allows an ideal bond between the hollow bar and the grouting medium

Main Advantages

- Fast and safe self-drilling installation
- Trouble-free application in unstable boreholes
- Easy and similar operating principle using on-site personnel and standard drilling machinery
- Drilling, installation, and optional grouting in a single operational step
- Proven installation process in difficult ground conditions
- Sound and efficient alternative compared to time-consuming cased drilling installation methods and products
- Same installation principle for all applications and ground conditions
- Minimization of ground disturbance
- Drill bit designs and diameters can be adjusted to different and varying ground conditions
- Minor space requirements for installation
- Functional adjustment of required lengths using couplings
- Broad range of hollow bar load capacity classes allows basic dimensioning and adaptation of design
- Robust system and high-strength thread designed for the demands of the construction industry
- High level of quality control measures among all levels of design and manufacturing

Quality Assurance

DSI Underground's comprehensive services include the conception, design, planning and installation of its systems as well as quality management and on-site supervision.

To satisfy your requirements and needs, DSI Underground has implemented a quality assurance process for the

DYWI® Drill Hollow Bar System in accordance with the principles of total quality management.

Quality means safety and reliability for our customers. Our aim is to provide product quality and safety through the entire manufacturing and distribution process.

**QUALITY
SAFETY
RELIABILITY**

Quality Assurance Process



System Components

Basic Elements

- Hollow bar
 - Used as drill rod during installation
 - Suitable for simultaneous or subsequent grouting
 - Tension or compression member
- Coupling
 - Continuous inside thread with middle stop or center bridge
 - Controlled drilling energy transmission
 - Full load bearing capacity
- Drill bit
 - One drill bit per installed unit
 - Different diameters and designs
 - Hardened and carbide insert versions
 - Optimized for various ground conditions

Design Examples



System Components

Anchorage and Foundation Constructions

- Nut
 - Hex or domed version
 - Weldable square nut
 - Different designs and dimensions available
- Plate
 - Flat or domed
 - Plate design adjusted to system demands
 - Various solutions for angle compensations and special plate designs available

Design Examples

Nail Head with Domed Plate



Anchor Head with Angle Compensation



Micropile Head (Compression Pile)

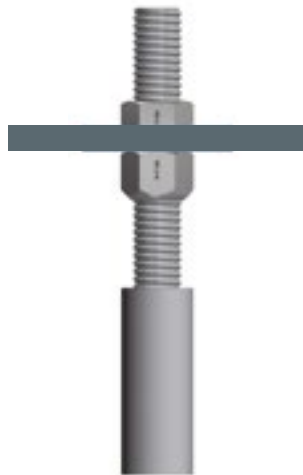

Reverse Anchor Head



System Accessories

- Structural elements
 - S-D expansion bolt
 - Expansion shell
 - Yielding anchor head
 - Lock nut
 - Eye nut and loop nut
 - Bail nut
 - Reverse anchor head
 - Lock coupling
 - Angle compensation disk
 - Sleeve for free length
 - Protective cap
- Drilling, grouting, and monitoring
 - Bayonet connector
 - Injection adapter
 - Rotary injection adapter
 - Grout mixing pump
 - DYWI® Inject Systems
 - Sealing coupling
- Post-injection coupling
 - Drill bit adapter
 - Rock drilling equipment
 - Centralizer
 - Injection flow-pressure meter
 - Pull testing equipment
 - Drill rod wrench
 - Tensioning tool

Rock and Soil Nail

Basic Concept

Soil nailing is a construction technique generally used for the stabilization of naturally unstable slopes or securing of over-steepened existing slopes, as well as the stabilization of retaining walls or embankments. For Underground applications, soil nails are also referred to as rock nails or bolts.

The basic concept of a soil or rock nail is based on the installation of longitudinal reinforcement elements into the ground. Hence, this load-bearing

system significantly differs from ground anchors (actively tensioned) and tensile piles, as the nail is installed un-tensioned (passive system). Consequently, nails increase the load-bearing capacity of the entire structure and act as a group of elements, withstanding tensile and shear forces acting on the nails. The center-to-center distance of nails must be chosen as such they are able to act as a complete nailing system. Prior to nail installation, the excavation face is generally

supported by shotcrete, precast concrete elements, mesh, or geotextiles. The design of a nail head construction depends on the application and the intended lifetime of the structure.

Conventional nail systems consisting of solid threaded bars are installed into pre-drilled holes and subsequently grouted. DYWI® Drill rock and soil nails are installed self-drilling, and are either grouted simultaneously during drilling or afterwards.

Schematic Drawing

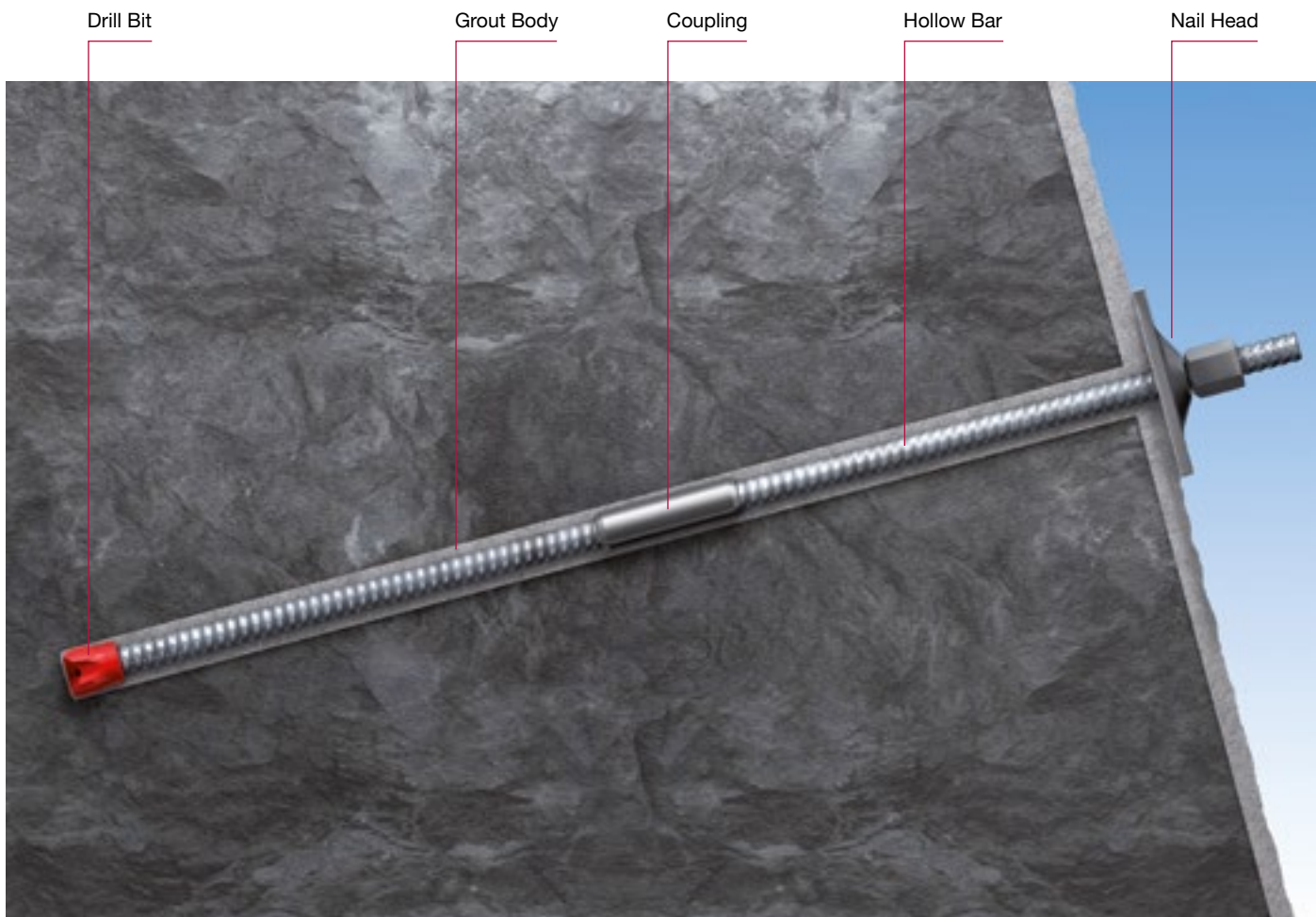

Approvals

- European Technical Approval (ETA)
- National technical approval in Austria (BmVIT)
- National technical approval in Germany (DIBt)
- German approval for Underground application
- National technical approval in Poland (IBDiM)
- Project-specific application

Rock and Soil Nail

Bonding Characteristics DYWI® Drill R32-400

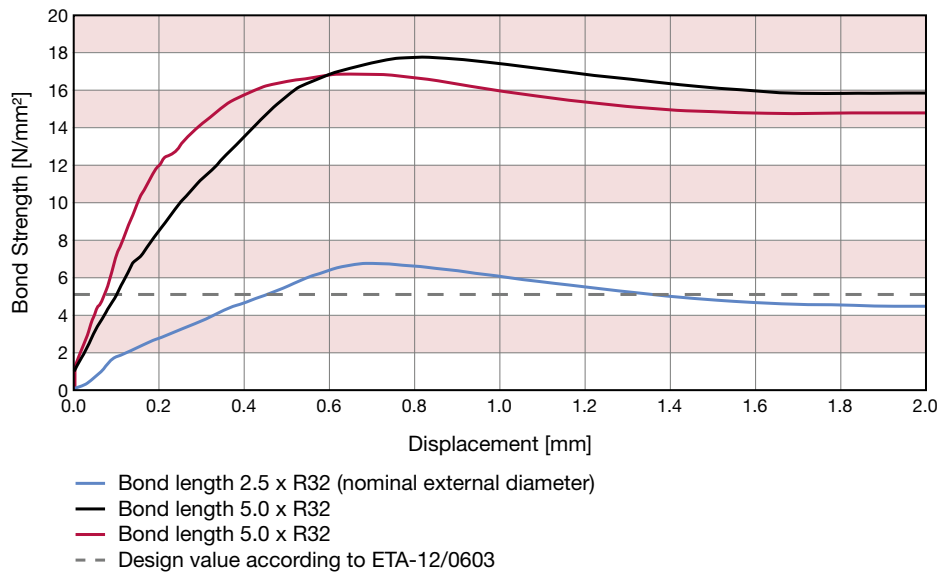

Applications



Ground Anchor

Basic Concept

In Civil Engineering, ground anchors are elements which are actively tensioned to support structures. Due to the active tensioning of the system, anticipated deformations are minimized or entirely eliminated. Fields of applications are either temporary – such as excavation pits and retaining walls – or permanent, e.g. tie backs or masts.

By definition, ground anchors consist of the following three system components:

- Bond length: the anchor is set in the borehole using cement grout (mortar), and is able to transfer the forces to the load-bearing soil via bond and skin friction
- Unbonded (or free) length: the tendon is uncoupled from the borehole wall using a sheathing (sleeve) which is sealed towards the coupling or hollow bar; the unbonded portion can freely extend and tension can be applied to the anchor system
- Anchor head: transfers the anchor force to the substructure (e.g. precast concrete elements) that needs to be anchored

Strand or solid bar ground anchor systems are installed into cased, pre-drilled holes and subsequently grouted. DYWI® Drill ground anchors are installed self-drilling with a pre-mounted sleeve attached to the drill string during installation.

Schematic Drawing

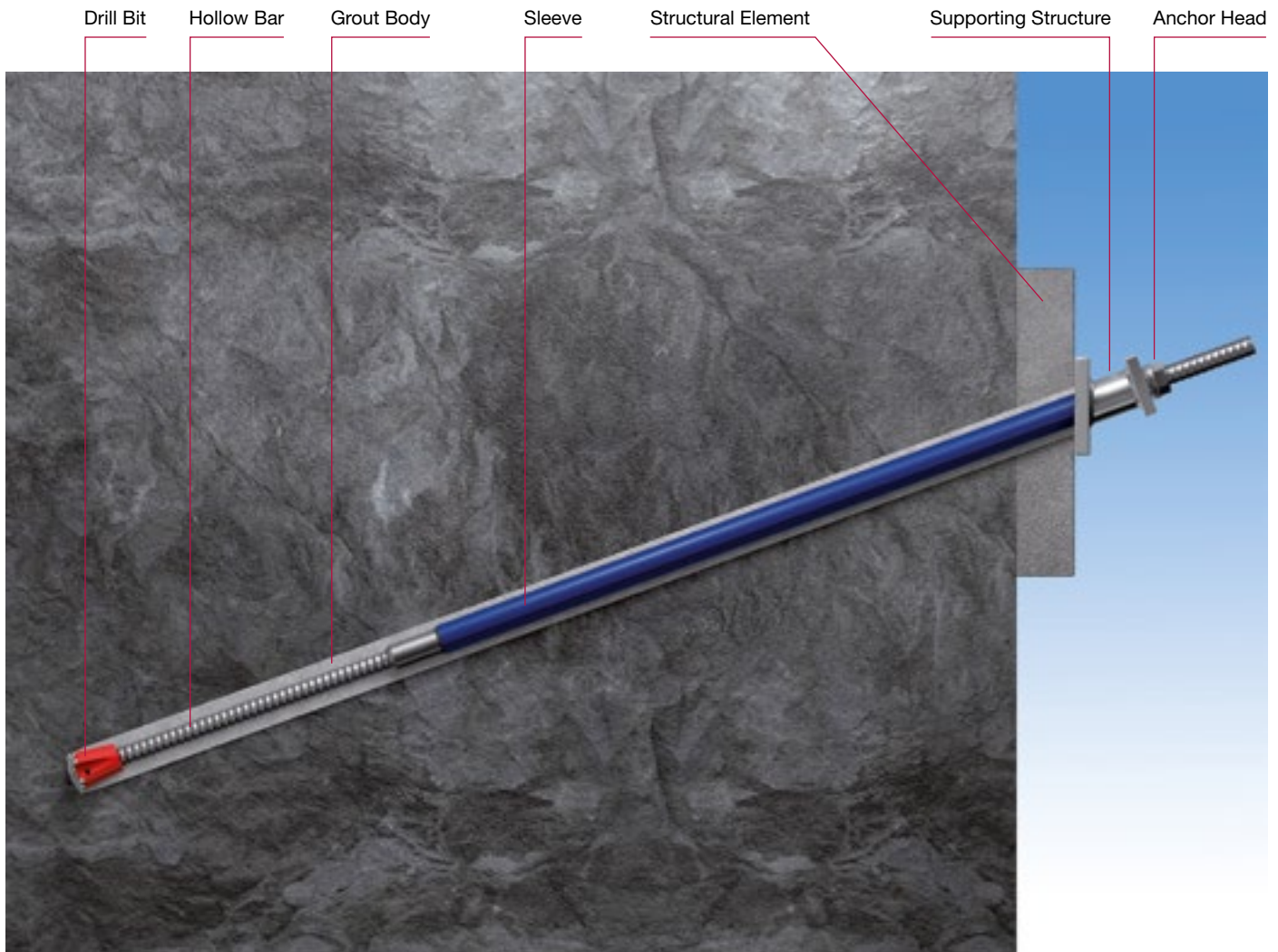

Ground Anchor

Torque-Tension Diagram DYWI® Drill Hollow Bar Type R32-280

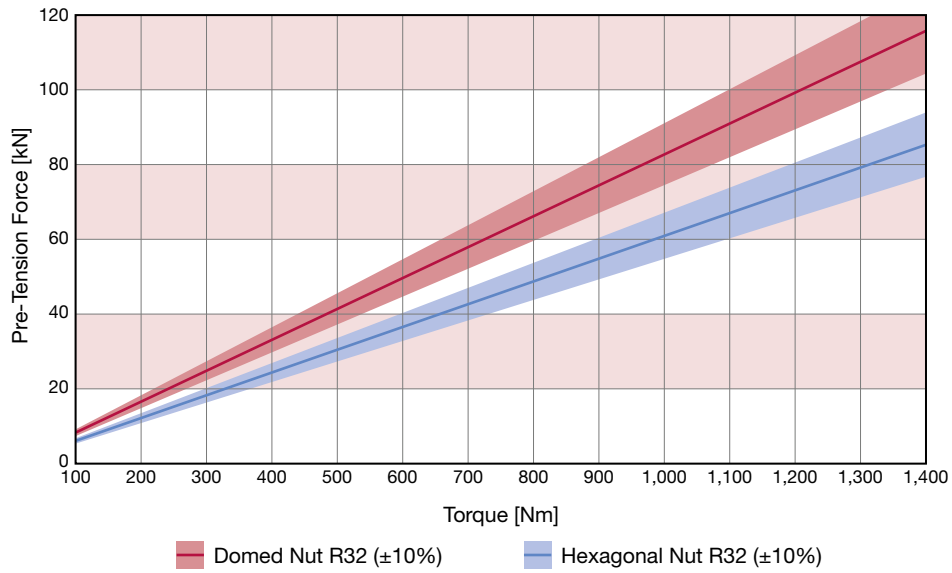

Domed Nut R32



Hexagonal Nut R32

Applications



Self-Drilling (S-D) Expansion Bolt



Micropile

Basic Concept

Pile foundation systems either consist of single piles (monopiles) or a group of piles which are connected to each other by a pile cap structure. Micropiles are typically used for underpinning civil structures, especially under limited space conditions or time constraints. By definition, micropiles consist of tubular steel elements with an outer

diameter range of approx. 60 - 200 [mm] (2.5 - 8.0 [in]). In general, micropiles act as a passive foundation system.

DYWI® Drill micropiles are installed self-drilling, typically using a large-diameter drill bit. Installation is accomplished with rotary or rotary-percussive drilling equipment, depending on the ground

conditions and intended installation length. Filling/grouting of the borehole is either performed simultaneously while drilling or afterwards. The grout serves as bonding medium which transfers the forces to the soil in terms of skin friction. A larger grout coverage also enhances the corrosion protection of the system.

Schematic Drawing (Tension Pile)

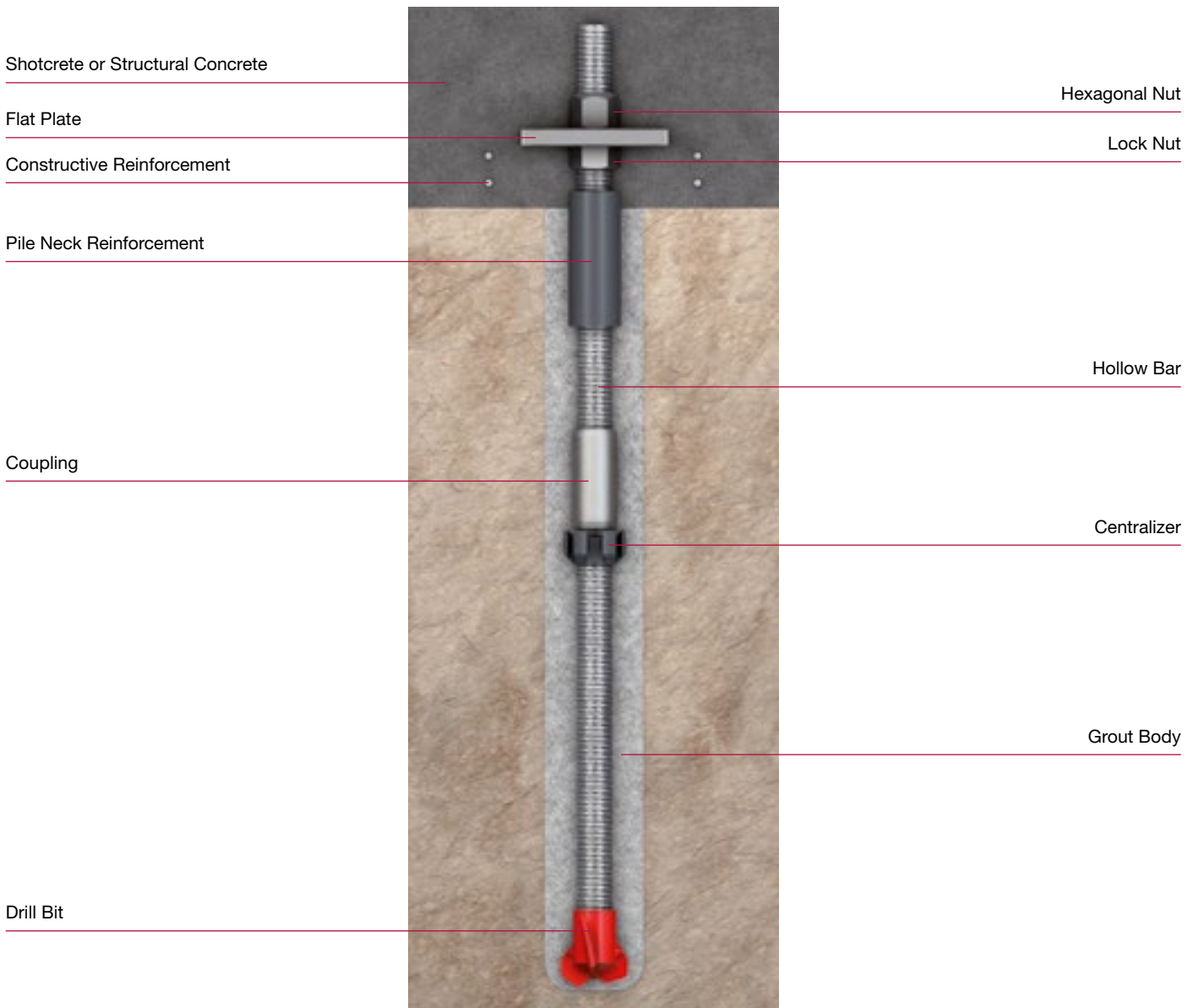

Approvals

- National technical approval in Austria (BmVIT)
- National technical approval in Poland (IBDiM)
- Project-specific

Micropile

Load Transfer Testing (ETAG 013)

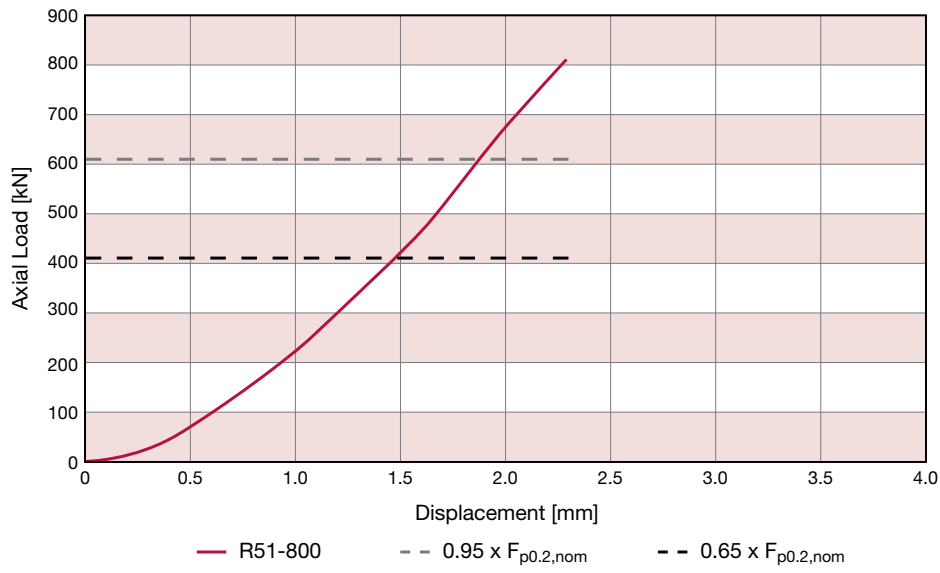

Applications



Spile and Injection Lance

Basic Concept

Spiles are used as temporary pre-support elements for the stabilization of the working area in tunnel headings. They are installed in the crown and sidewall area of a tunnel, to ensure the stability of the perimeter of the open span until the primary lining is installed. Injection lances are used for the targeted transport of a cement or resin based

injection medium to the designated injection area.

In difficult ground and in case of unstable boreholes, DYWI® Drill spiles and injection lances are a preferred solution to ensure a safe and fast installation procedure. Self-drilling spiles and injection lances allow the use of default Underground

drilling machinery (jumbos); threaded hollow bars enable a durable and easy connection to any injection hose system.

A detailed description of spiles and injection lances is included in the sections pre-support and chemical injection.

Schematic Drawing

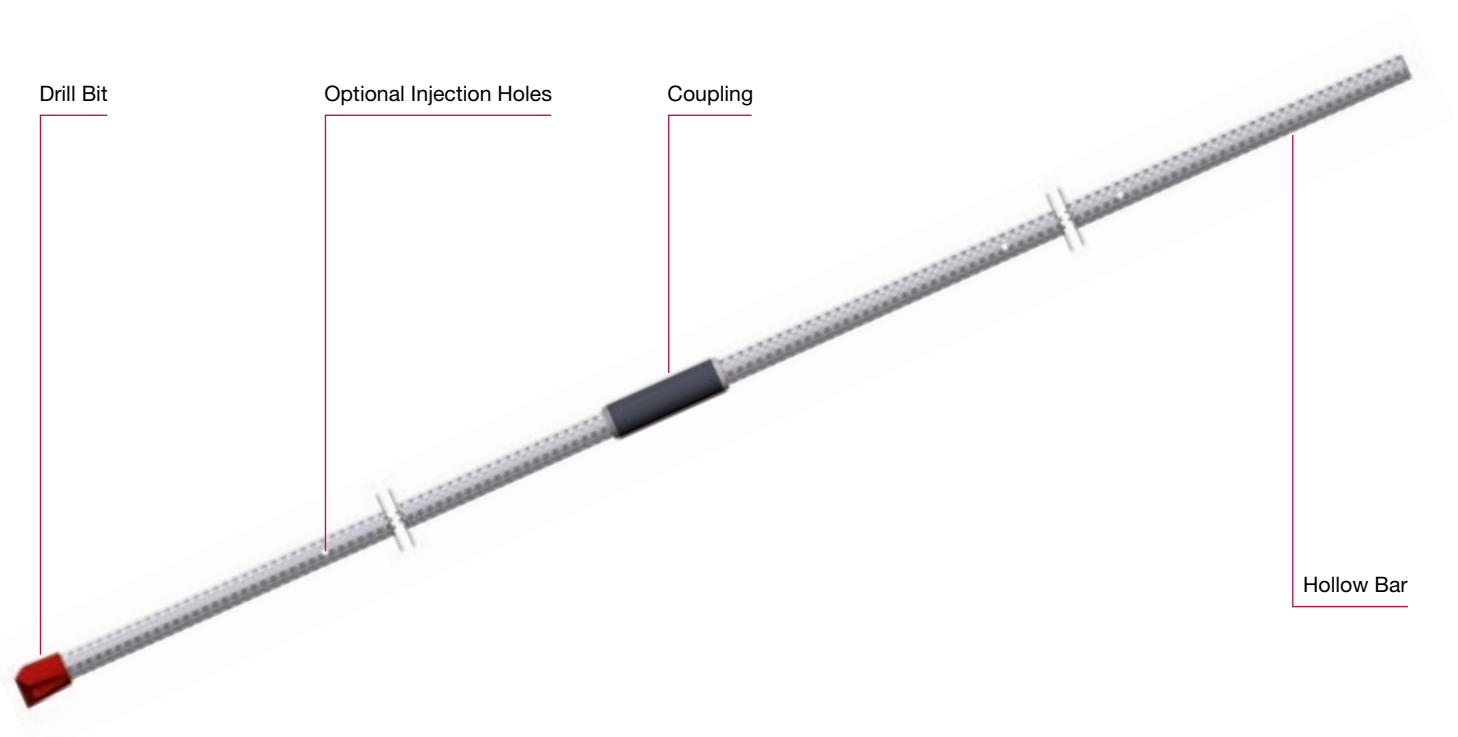

Bending Tests

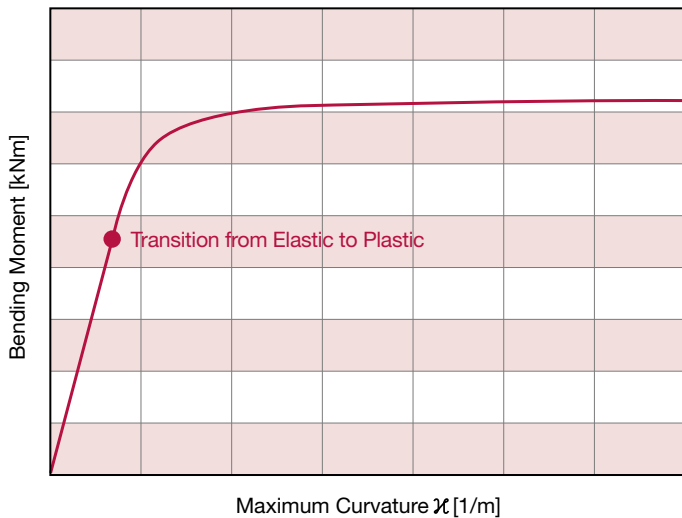

Spile and Injection Lance

Applications



Specifications

SI Units

Technical Data Series R32

Characteristic Value / Type ¹⁾	Symbol	Unit	R32-210	R32-250	R32-280	R32-320	R32-360	R32-400
Nominal external diameter	$D_{e,nom}$	[mm]	32					
Actual external diameter	D_e	[mm]	31.1					
Average internal diameter ²⁾	D_i	[mm]	21.0	20.0	18.5	16.5	15.0	12.5
Nominal cross-sectional area ³⁾	S_0	[mm ²]	340	370	410	470	510	560
Nominal weight ⁴⁾	m	[kg/m]	2.65	2.90	3.20	3.70	4.00	4.40
Specific rib area	f_R	[-]	0.13					
Nominal yield load ⁵⁾	$F_{p0.2,nom}$	[kN]	160	190	220	250	280	330
Nominal ultimate load ⁵⁾	$F_{m,nom}$	[kN]	210	250	280	320	360	400
Yield strength ⁶⁾	$R_{p0.2}$	[N/mm ²]	470	510	540	530	550	590
Ultimate strength ⁶⁾	R_m	[N/mm ²]	620	680	680	680	710	710
$R_m/R_{p0.2}$ ⁷⁾	-	[-]	≥ 1.15					
Ultimate load strain ⁷⁾	A_{gt}	[%]	≥ 5.0					
Fatigue strength $2 \cdot \sigma_a$ ⁸⁾	-	[N/mm ²]	190					
Bond strength ⁹⁾	τ_{ak}	[N/mm ²]	5.1					

Technical Data Series R38

Characteristic Value / Type ¹⁾	Symbol	Unit	R38-420	R38-500	R38-550
Nominal external diameter	$D_{e,nom}$	[mm]	38		
Actual external diameter	D_e	[mm]	37.8		
Average internal diameter ²⁾	D_i	[mm]	21.5	19.0	17.0
Nominal cross-sectional area ³⁾	S_0	[mm ²]	660	750	800
Nominal weight ⁴⁾	m	[kg/m]	5.15	5.85	6.25
Specific rib area	f_R	[-]	0.13		
Nominal yield load ⁵⁾	$F_{p0.2,nom}$	[kN]	350	400	450
Nominal ultimate load ⁵⁾	$F_{m,nom}$	[kN]	420	500	550
Yield strength ⁶⁾	$R_{p0.2}$	[N/mm ²]	530	530	560
Ultimate strength ⁶⁾	R_m	[N/mm ²]	640	670	690
$R_m/R_{p0.2}$ ⁷⁾	-	[-]	≥ 1.15		
Ultimate load strain ⁷⁾	A_{gt}	[%]	≥ 5.0		
Fatigue strength $2 \cdot \sigma_a$ ⁸⁾	-	[N/mm ²]	190		
Bond strength ⁹⁾	τ_{ak}	[N/mm ²]	5.1		

Technical Data Series R51

Characteristic Value / Type ¹⁾	Symbol	Unit	R51-550	R51-660	R51-800	R51-950
Nominal external diameter	$D_{e,nom}$	[mm]	51			
Actual external diameter	D_e	[mm]	49.8			
Average internal diameter ²⁾	D_i	[mm]	34.5	33.0	29.0	26.0
Nominal cross-sectional area ³⁾	S_0	[mm ²]	890	970	1,150	1,225
Nominal weight ⁴⁾	m	[kg/m]	6.95	7.65	9.00	9.60
Specific rib area	f_R	[-]	0.13			
Nominal yield load ⁵⁾	$F_{p0.2,nom}$	[kN]	450	540	640	780
Nominal ultimate load ⁵⁾	$F_{m,nom}$	[kN]	550	660	800	950
Yield strength ⁶⁾	$R_{p0.2}$	[N/mm ²]	510	560	560	640
Ultimate strength ⁶⁾	R_m	[N/mm ²]	620	680	700	770
$R_m/R_{p0.2}$ ⁷⁾	-	[-]	≥ 1.15			
Ultimate load strain ⁷⁾	A_{gt}	[%]	≥ 5.0			
Fatigue strength $2 \cdot \sigma_a$ ⁸⁾	-	[N/mm ²]	190			
Bond strength ⁹⁾	τ_{ak}	[N/mm ²]	5.1			

Specifications

SI Units

Technical Data Series T76

Characteristic Value / Type ¹⁾	Symbol	Unit	T76-1300	T76-1650	T76-1900
Nominal external diameter	$D_{e,nom}$	[mm]		76	
Actual external diameter	D_e	[mm]	74.6		75.6
Average internal diameter ²⁾	D_i	[mm]	56.0	52.0	47.0
Nominal cross-sectional area ³⁾	S_0	[mm ²]	1,590	1,975	2,360
Nominal weight ⁴⁾	m	[kg/m]	12.5	15.5	18.5
Specific rib area	f_R	[-]	0.20		0.24
Nominal yield load ⁵⁾	$F_{p0.2,nom}$	[kN]	1,000	1,200	1,500
Nominal ultimate load ⁵⁾	$F_{m,nom}$	[kN]	1,300	1,650	1,900
Yield strength ⁶⁾	$R_{p0.2}$	[N/mm ²]	630	610	640
Ultimate strength ⁶⁾	R_m	[N/mm ²]	820	840	810
$R_m/R_{p0.2}$ ⁷⁾	-	[-]		≥ 1.15	
Ultimate load strain ⁷⁾	A_{gt}	[%]		≥ 5.0	

1) Status: 2016-04, all values are subject to change

2) Calculated from the actual external diameter, the average thread height, and the nominal cross-sectional area, rounded

3) Calculated from the nominal weight $S_0 = 10^3 \times m / 7.85$

4) Deviation: -3% to +9%

5) Characteristic value (5%-fractile)

6) Calculated from the nominal load and the nominal cross-sectional area, rounded

7) Characteristic value (10%-fractile)

8) Values are determined at an upper force $F_{up} = 0.7 \times F_{p0.2,nom}$ and 2 million load cycles

9) Characteristic values, determined by pull-out tests using mortar with a prism compressive strength ≥ 55 [N/mm²]

Modulus of elasticity $E = 205,000$ [N/mm²]



Specifications

US Customary Units

Technical Data Series R32

Characteristic Value / Type ¹⁾	Symbol	Unit	R32-210	R32-250	R32-280	R32-320	R32-360	R32-400
Nominal external diameter	D _{e,nom}	[in]	1.26					
Actual external diameter	D _e	[in]	1.22					
Average internal diameter ²⁾	D _i	[in]	0.83	0.79	0.73	0.65	0.59	0.49
Nominal cross-sectional area ³⁾	S ₀	[in ²]	0.53	0.57	0.64	0.73	0.79	0.87
Nominal weight ⁴⁾	m	[lb/ft]	1.78	1.95	2.15	2.49	2.69	2.96
Specific rib area	f _R	[-]	0.13					
Nominal yield load ⁵⁾	F _{p0.2,nom}	[kip]	36	43	49	56	63	74
Nominal ultimate load ⁵⁾	F _{m,nom}	[kip]	47	56	63	72	81	90
Yield strength ⁶⁾	R _{p0.2}	[ksi]	68	74	78	77	80	86
Ultimate strength ⁶⁾	R _m	[ksi]	90	99	99	99	103	103
R _m /R _{p0.2} ⁷⁾	-	[-]	≥ 1.15					
Ultimate load strain ⁷⁾	A _{gt}	[%]	≥ 5.0					
Fatigue strength 2·σ _a ⁸⁾	-	[ksi]	28					
Bond strength ⁹⁾	τ _{ak}	[ksi]	0.7					

Technical Data Series R38

Characteristic Value / Type ¹⁾	Symbol	Unit	R38-420	R38-500	R38-550
Nominal external diameter	D _{e,nom}	[in]	1.50		
Actual external diameter	D _e	[in]	1.49		
Average internal diameter ²⁾	D _i	[in]	0.85	0.75	0.67
Nominal cross-sectional area ³⁾	S ₀	[in ²]	1.02	1.16	1.24
Nominal weight ⁴⁾	m	[lb/ft]	3.46	3.93	4.20
Specific rib area	f _R	[-]	0.13		
Nominal yield load ⁵⁾	F _{p0.2,nom}	[kip]	79	90	101
Nominal ultimate load ⁵⁾	F _{m,nom}	[kip]	94	112	124
Yield strength ⁶⁾	R _{p0.2}	[ksi]	77	77	81
Ultimate strength ⁶⁾	R _m	[ksi]	93	97	100
R _m /R _{p0.2} ⁷⁾	-	[-]	≥ 1.15		
Ultimate load strain ⁷⁾	A _{gt}	[%]	≥ 5.0		
Fatigue strength 2·σ _a ⁸⁾	-	[ksi]	28		
Bond strength ⁹⁾	τ _{ak}	[ksi]	0.7		

Technical Data Series R51

Characteristic Value / Type ¹⁾	Symbol	Unit	R51-550	R51-660	R51-800	R51-950
Nominal external diameter	D _{e,nom}	[in]	2.01			
Actual external diameter	D _e	[in]	1.96			
Average internal diameter ²⁾	D _i	[in]	1.36	1.30	1.14	1.02
Nominal cross-sectional area ³⁾	S ₀	[in ²]	1.38	1.50	1.78	1.90
Nominal weight ⁴⁾	m	[lb/ft]	4.67	5.14	6.05	6.45
Specific rib area	f _R	[-]	0.13			
Nominal yield load ⁵⁾	F _{p0.2,nom}	[kip]	101	121	144	175
Nominal ultimate load ⁵⁾	F _{m,nom}	[kip]	124	148	180	214
Yield strength ⁶⁾	R _{p0.2}	[ksi]	74	81	81	93
Ultimate strength ⁶⁾	R _m	[ksi]	90	99	102	112
R _m /R _{p0.2} ⁷⁾	-	[-]	≥ 1.15			
Ultimate load strain ⁷⁾	A _{gt}	[%]	≥ 5.0			
Fatigue strength 2·σ _a ⁸⁾	-	[ksi]	28			
Bond strength ⁹⁾	τ _{ak}	[ksi]	0.7			

Specifications

US Customary Units

Technical Data Series T76

Characteristic Value / Type ¹⁾	Symbol	Unit	T76-1300	T76-1650	T76-1900
Nominal external diameter	$D_{e,nom}$	[in]		3.0	
Actual external diameter	D_e	[in]	2.94		2.98
Average internal diameter ²⁾	D_i	[in]	2.20	2.05	1.85
Nominal cross-sectional area ³⁾	S_0	[in ²]	2.46	3.06	3.66
Nominal weight ⁴⁾	m	[lb/ft]	8.40	10.42	12.43
Specific rib area	f_R	[-]	0.20		0.24
Nominal yield load ⁵⁾	$F_{p0.2,nom}$	[kip]	225	270	337
Nominal ultimate load ⁵⁾	$F_{m,nom}$	[kip]	292	371	427
Yield strength ⁶⁾	$R_{p0.2}$	[ksi]	91	88	93
Ultimate strength ⁶⁾	R_m	[ksi]	119	122	117
$R_m/R_{p0.2}$ ⁷⁾	-	[-]		≥ 1.15	
Ultimate load strain ⁷⁾	A_{gt}	[%]		≥ 5.0	

1) Status: 2016-04, all values are subject to change

2) Calculated from the actual external diameter, the average thread height, and the nominal cross-sectional area, rounded

3) Calculated from the nominal weight

4) Deviation: -3% to +9%

5) Characteristic value (5%-fractile)

6) Calculated from the nominal load and the nominal cross-sectional area, rounded

7) Characteristic value (10%-fractile)

8) Values are determined at an upper force $F_{up} = 0.7 \times F_{p0.2,nom}$ and 2 million load cycles

9) Characteristic values, determined by pull-out tests using mortar with a prism compressive strength ≥ 8 [ksi]

Modulus of elasticity $E = 29,700$ [ksi]



Corrosion Protection

Definitions, Principle, and Protection

Introduction

By definition, corrosion is the reaction of a material with its ambient environment, causing a measurable change in the material (e.g. rust) which can lead to function impairment of a component or system. From a practical standpoint, a complete corrosion protection cannot be achieved.

Therefore, applied protective methods are directed towards a reduction of the corrosion attack and the respective damages to the reinforcement or ground control elements during their intended lifetime.

Corrosion refers to the entire system, e.g. reinforcement element, grout body, ground, and corrosion media, and is expressed in terms of two main mechanisms of action: "corrosion of concrete" and "corrosion of the reinforcement in the concrete".

Corrosion of Concrete

This principle applies for grout and cement mortar. Three main factors of concrete corrosion are pH-value, presence of oxygen, and ion concentration.

Concrete damage on the surface is a first requirement for the penetration of harmful substances as far as the reinforcement in the concrete is located.

Subsequently, the corrosion of reinforcing elements reduces the strength of the structure. Dense and impenetrable concrete is more protected against corrosion than a porous one.

Corrosion of the Reinforcement in the Concrete

In properly fabricated reinforced concrete structures, reinforcement elements are generally not subjected to corrosion. Hence, if an adequate gas and water permeability of the concrete through cracks occurs, air containing carbon dioxide, sulfides, or corrosive water

in general can be transferred to the reinforcement, causing steel corrosion to start.

For civil applications, where a proper and complete cement stone or grout cover cannot be guaranteed in many

cases, the sacrificial corrosion principle is a recommended tool for the design of ground control systems with an extended working life. Hence, a cement stone coverage and respective carbonation generally helps to reduce the corrosion rate.



Blank



Sacrificial
Corrosion
Protection



Hot-Dip Galvanizing



Double Corrosion Protection

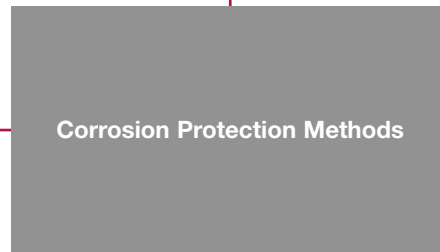

Corrosion Protection Methods

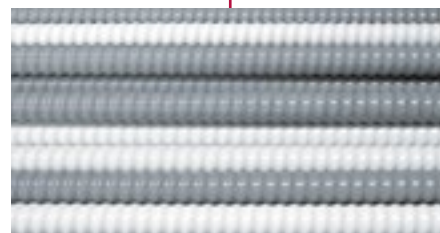

Duplex Coating



Cement Stone Coverage

Corrosion Protection

Corrosion Protection Methods

The selection of the optimal corrosion protection method(s) depends on the corrosion potential of the environment, and the type as well as the intended service life of the structure. The load-bearing element, transition zone between borehole and surface, and the head construction must be assessed separately.

Corrosion protection methods are divided into two main groups. The first one is called active, and comprises all

influencing methods which eliminate or reduce the corrosion reaction. A common example for active corrosion protection is encapsulation with concrete. The second one is passive corrosion protection, including methods to produce a protective layer on corrosion endangered parts, for example duplex coating systems.

A preferred and recommend active corrosion protection method is the sacrificial corrosion design principle,

which is based on corrosion rates of blank and galvanized steel depending on the corrosive environment and the expected lifetime, without considering cement stone encapsulation. Double corrosion protection (e.g. factory-made grouted corrugated sheathing) is not used for self-drilling applications; duplex type coatings can be damaged by the self-drilling installation process.

Sacrificial Corrosion Protection

- Definition of corrosion rates (sacrificial corrosion), depending on ground conditions and other influencing factors
- Element design in accordance with an increase of cross-section due to corrosion over the intended service life
- The system inherent encapsulation with cement mortar or grout is not considered
- Blank or galvanized ground control elements – galvanization leads to a delay of the corrosion start and to an increased service life
- Hot-dip galvanizing: preferred method for load-bearing system components in accordance with ISO 1461 or national standards
- Corrosion protection of head constructions must be considered separately

Working Life According to European Standards and Approvals

Working Life in Years ¹⁾	Steel ²⁾	Corrosion in [mm] for different Corrosion Loads ³⁾		
		Low	Medium	High
2	Blank	0	0	0.2
	Hot-dip galvanized	0	0	0.1
7	Blank	0.2	0.2	0.5
	Hot-dip galvanized	0	0.1	0.4
30	Blank	0.3	0.6	–
	Hot-dip galvanized	0.1	0.4	–
50	Blank	0.5	1.0	–
	Hot-dip galvanized	0.3	0.7	–

1) A working life up to 100 years can be considered in accordance with EN 1993-5

2) Typically applied average zinc layer thickness: ≥ 85 [µm] in accordance with ISO 1461

3) According to ETA-12/0603. EN 14490 and EN 14199 also define classes of ground aggressiveness and corrosion rates for achieving the intended working life; Low, medium, and high corrosion loads are defined in EN 12501-2

Double Corrosion Protection

- Factory-made corrugated sheathing with controlled crack width
- Not applicable for self-drilling installation
- Installation into pre-drilled boreholes and post-injection

Duplex Coating

- Painting or powder coating of a previously galvanized element
- Protective layer can be destroyed during the self-drilling installation process
- Coating thickness depending on the application

Cement Stone Coverage

- Encapsulation of load-bearing elements
- Carbonation reduces the influence of corrosive environments
- Guaranteed full encapsulation and limitation of crack development required for a successful application of this method

Drill Bits

Introduction

The drilling performance is affected by the choice of the proper drill bit, which mainly depends on the hardness and abrasiveness of the ground, the drilling method, borehole diameter, and borehole length.

Furthermore, the drill bit and therefore the borehole diameter depend on the application (e.g. rock or soil nails, micropiles, etc.). A key issue during the self-drilling installation procedure is to minimize the impact on the surrounding soil or rock by optimizing drilling rates and the applied energy.

For example in mixed fill type soils, drill bit types typically used are two-stage

retro flush drill bits, arc-shaped drill bits, or cross drill bits.

Ground such as clays, loams, soft slate, or clayey silt is removed in terms of cutting and scraping. For these soil types, two-stage flush drill bits, arc-shaped drill bits, and cross drill bits are typically used.

In harder soil or rock, the use of percussive energy plays a more dominant role. In this case, button drill bits, cross drill bits, or arc-shaped drill bits are typically used in combination with carbide inserts.



Application Range

Designation	Ground Properties		Drill Bit Type ¹⁾								
	Description	Examples	Two-Stage R-Flush and RS-Flush	Arc-Shaped Button, Hardened	Arc-Shaped Button, Carbide Inserts	Arc-Shaped, Hardened	Arc-Shaped, Carbide Inserts	Cross, Hardened	Cross, Carbide Inserts	Button, Hardened	Button, Carbide Inserts
Alluvium	Humus and organic layers	Top soil or flowing ground, possibly water-bearing									
	Peat and sludge		X	(X)		(X)			X		
	Gravel, sand, silt and clay mixtures	Sedimentary fills, fault zone material									
Sands	Non-cohesive and cohesive sand, gravel, and mixtures with small clay contents	Easily removable soil Mixed fills	X	(X)	(X)	X			X		
	Cohesive soils	Mixtures of sand, gravel, silt and clay	Average removable soil Mixed fills	(X)	X	X	X	(X)	X	(X)	
Gravel		Soils with a higher gravel content of larger sizes Riverbeds		(X)	X	(X)	X	(X)	X		
Soft rock	Jointed, brittle, weathered	Average removable rock			X	(X)	X		X	X	X
	Conglomerate	Limestone, schist									
Hard rock	Higher abrasiveness and/or compressive strength, less fractured	Difficult removable rock						(X)	(X)	(X)	X
		Volcanic rock, hard sandstone, concrete									

¹⁾ Indications are general guidelines, and depend on on-site conditions. Borehole diameter and drilling length influence drill bit selection. "X" markings show standard applications, "(X)" markings possible combinations

Drill Bits

Portfolio

- Successful installation performance depends on selecting the adequate drill bit
- Large drill bit portfolio for various ground conditions
- Selection of optionally used centralizers must be accomplished dependent on the drill bit diameter
- Optimized in regards to installation parameters such as cutting ability and drilling performance
- Adjusted to the requirements of Civil Engineering as well as for Underground applications
- Further information regarding drill bit design and selection are included in a separate leaflet on drill bits for the DYWI® Drill Hollow Bar System

Diameter ¹⁾		Thread	Drill Bit Type									
[mm]	[in]		Two-Stage R-Flush (Retro-Flush), Hardened	Two-Stage RS-Flush (Retro & Side Flush), Hardened	Arc-Shaped Button, Hardened	Arc-Shaped Button, Carbide Inserts	Arc-Shaped, Hardened	Arc-Shaped, Carbide Inserts	Cross, Hardened	Cross, Carbide Inserts	Button, Hardened	Button, Carbide Inserts
51	2.0	R32					X	X	X	X	X	X
		R38										
		R51										
		T76										
76	3.0	R32		X	X	X	X	X	X	X	X	X
		R38			X	X	X		X	X	X	X
		R51			X	X					X	X
		T76										
90	3.5	R32			X	X						
		R38			X	X			X	X	X	X
		R51			X	X						
		T76										
100	3.9	R32		X								
		R38		X							X	X
		R51							X	X	X	X
		T76										
115	4.5	R32										
		R38			X	X			X	X	X	X
		R51			X	X			X	X	X	X
		T76										
130	5.1	R32										
		R38		X								
		R51			X						X	
		T76			X	X			X	X	X	X
150	5.9	R32										
		R38										
		R51		X								
		T76	X		X	X			X		X	X
200	7.9	R32										
		R38										
		R51										
		T76	X						X			

1) X-marked fields indicate standard drill bit types, other dimensions available on request

Self-Drilling Installation

Self-drilling installation may be accomplished either manually or semi-automated, depending on the available drilling machinery.

The DYWI® Drill Hollow Bar System offers high rates of installation, as drilling and grouting can be combined into one single operational procedure.

Selection of the proper drilling machinery is key to ensure efficient and sound drilling.



Installation Parameters

Self-drilling installation is accomplished using either rotary or rotary-percussive drilling machines. Depending on the

application, the ground conditions, the DYWI® Drill type as well as the final installation length, the main drilling

parameters which are listed and described in the following have to be adjusted accordingly.

Rotation Speed

The rotation speed is controlled by the rotation motor used. While Underground rotation motors of (hydraulic) rock drills run on higher rotation rates and the final installed element length is normally short, experience from Civil Engineering applications has shown that rates in the range of 120 - 150 [rpm] provide sound results.

Torque

The recommended maximum torque for the installation of the DYWI® Drill Hollow Bar System has been determined for different types and feed ratios. These values have been determined numerically with a safety factor of 0.7 with regards to the yield load.

Percussion

Different types of rock drilling equipment feature a wide range of percussion rates. In general, the same percussion rate as for default "smooth rock/soil drilling" using drill steel and multiple-use drill bits should be applied. For directional stability and drilling efficiency in Civil Engineering, percussion rates of 300 to 600 [bpm] have shown good results.

Feed

The recommended maximum feed range for installation depending on the DYWI® Drill type and the applied torque is shown in the following diagram.

For shorter installation lengths required for Underground applications, adjustment of the feed rate is not as critical as in Civil Engineering, where the stability

and accuracy of the drill string are key features. Here, the feed pressure should be adjusted so that it matches the achievable smooth drilling rate.

Self-Drilling Installation

Grouting

Grout mixing pumps used for injection of the DYWI® Drill Hollow Bar System typically comprise of a mixing and a pumping unit. Those injection pumps must feature a complete mixing of the grout and a steady pumping pressure. For simultaneous drilling and grouting, pressure requirements are not high (< 7 [bar] / 100 [psi]), hence a constant supply rate is required to ensure that the grout circulates within the borehole during drilling. The grouting pressure must be customized to respective and machine capacity.

For example, the required pressure is higher for long ground anchors than for short bolts.

The consumption of injection medium mainly depends on:

- Amount and type of flushing medium
 - Air, water, water-air mixture, or grout
 - Simultaneous drilling and grouting is a combined flushing and injection technique

- Ground conditions
 - Non-binding soils or fractured rock result in an increased consumption of injection media
- Water-cement ratio
 - Generally between 0.35 and 0.70

Besides the common self-drilling installation feature, grouting may either be performed while drilling with a rotary injection adapter or after the drilling operation. This subsequent grouting procedure is accomplished with a conical push adapter or a threaded coupling connector. In case given ground conditions require further improvement, multiple injections using post-injection couplings further enhance the grouting performance. Additional injection holes drilled into hollow bars may also support grout distribution along the entire element length; however, they reduce the load-bearing capacity of the hollow bar.



Simultaneous Drilling and Grouting

This technique ensures that the grout is properly and uniformly distributed over the entire installation length as drilling advances, and has shown proper results in ground types where a cement grout bulb around the hollow bar cannot be

properly established by post injection grouting. Grout which replaces water or air as a flushing medium is injected into the drill string over a rotary injection adapter; it permeates the ground concurrently with the installation and

forms bulbs for increased bond strength. For granular soils, a small return of grout at the collar of the borehole is required, for cohesive soils, larger grouting/flushing amounts may be necessary.

Recommended Pairs of Impact Energy and Torque

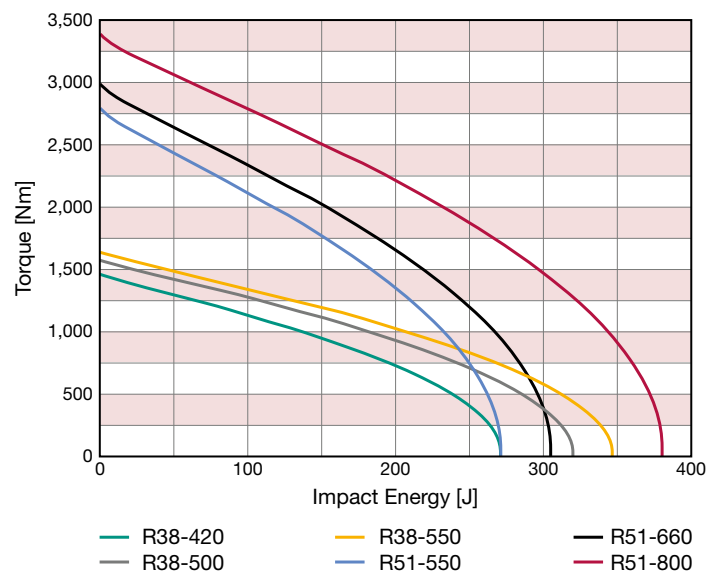
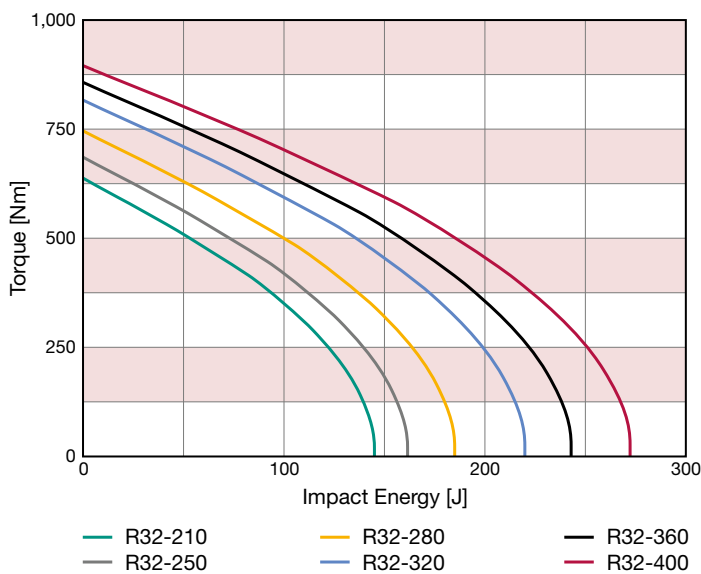

Self-Drilling Installation



Simultaneous Drilling and Grouting

- Assembly of the DYWI® Drill Hollow Bar System and connection to the rotary injection adapter



- Rotary self-drilling installation and simultaneous grouting



- Optional extension using couplings



- De-coupling from the rotary injection adapter



- Assembly of anchorage or head construction (plate and nut), depending on the application



Drilling and Subsequent Grouting

- Assembly of the DYWI® Drill Hollow Bar System and connection to the rock drill



- Rotary percussive self-drilling installation without casing: single-use drill bit and hollow bar drill steel, water or air-water mixture flushing



- Optional extension using couplings



- De-coupling from the drilling machinery; subsequent grouting using an injection adapter



Testing and Monitoring

Introduction

On-site testing ensures proper functioning and allows to prove the performance of the installed DYWI® Drill Hollow Bar System. Depending on the application, an appropriate test method must be selected. Tests are carried out on trial elements. Those trial elements should be prepared and installed as performed during the construction process.

For example, testing of ground anchors involves three general testing types for quality control purposes:

- Investigation tests
 - Conducted on trial anchors installed prior to the main works
 - Investigation tests provide information on the expected performance of working anchors, suitability of design, and levels of safety

- Suitability tests
 - Conducted on ground anchors identical to the working anchors
 - Data provides a reference against which the performance of the working anchors can be measured
- Acceptance tests
 - May be applied to all working anchors
 - Test loading demonstrates the ground anchor's ability to withstand a load exceeding its working load

For micropiles as well as rock and soil nails, investigation tests and suitability tests are the preferred testing types. In the course of investigation tests, the ultimate load resistance at the ground-grout interface and the characteristics of the system in the working load range are determined. Suitability tests confirm a particular design in comparable ground conditions by test loading.

Pull-out tests are the default on-site testing procedure for ground anchors, soil nails, and bolts. Depending on the loading mechanism (tensile, compressive, or alternating), micropiles are tested either by pull-out tests and/or static load tests. Spiles and injection lances are generally not tested in-situ.

Testing and monitoring features economic advantages during the product service life cycle. With the information from in-situ tests at hand, an optimization of the construction design may be possible. Monitoring and regular inspection increase the service life of both the used product and the entire structure, because structural damages or imperfections of construction can be detected at an early stage.

Pull-Out Tests

A pull-out (or simply pull) test measures the characteristics and the performance of the load transfer mechanism of the installed DYWI® Drill Hollow Bar System. Pull tests can be conducted on actual lengths (soil nails) or on short encapsulated samples.

At the excess length of the installed hollow bar, a tensile load is applied by using a hydraulic tension jack with a load measurement system. A hydraulic hollow core cylinder and a press chair as bearing on the soil or rock surface are connected to the hollow bar with a pull adapter and fixing nut. Tensile loading is applied over the extension of the hollow core cylinder. During pull-out tests, force and displacement of the hollow bar must be measured and recorded.

In general, pull test equipment includes the following main parts:

- Tension adapter, pull rod, and fixing nut
- Press chair (bearing element)
- Hydraulic system: hollow core cylinder and pump
- Load and displacement measurement systems

Further information regarding pull testing equipment is included in the section rock reinforcement.

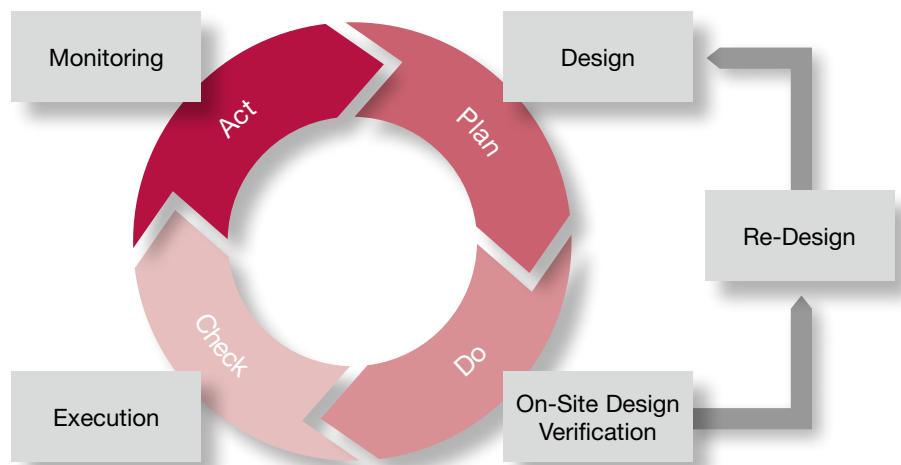

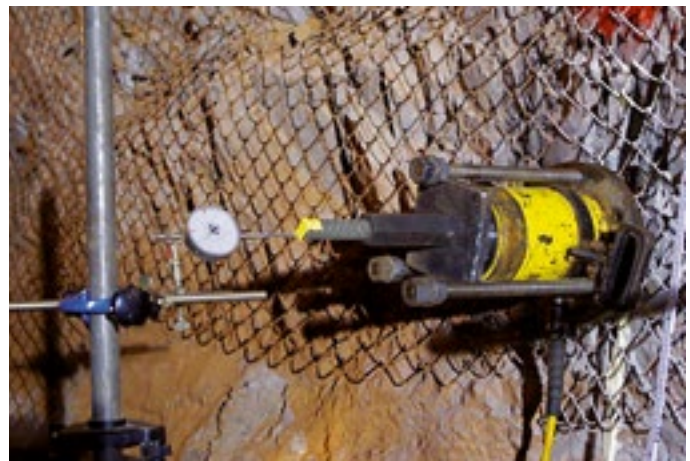

In-Situ Pull Testing (DIN 21521-2): Load-Displacement Diagram R32-360 with DYWI® Inject SILO 8044-M

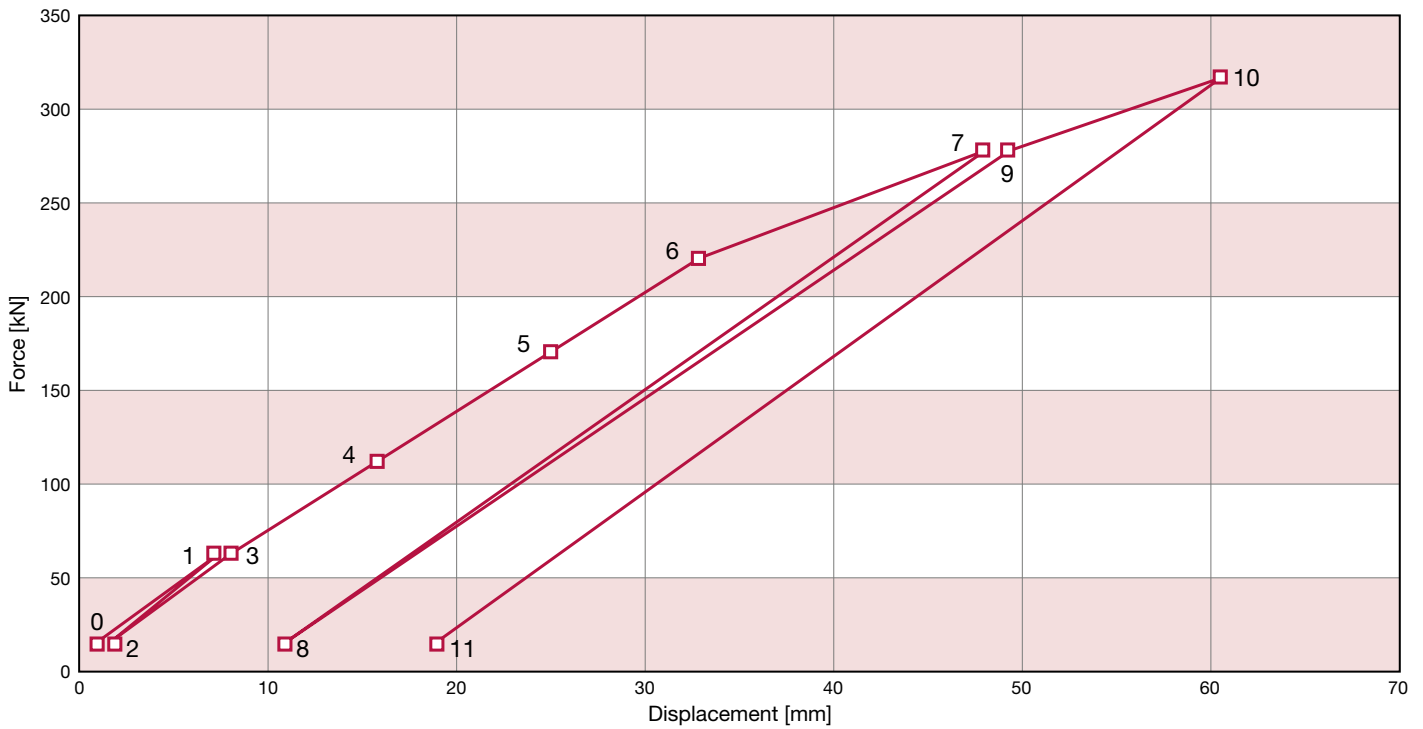

Further References

- EN 1461: Hot dip galvanized coatings on fabricated iron and steel articles – Specifications and test methods
- EN 12501-1: Protection of metallic materials against corrosion – Corrosion likelihood in soil – Part 1: General
- EN 12501-2: Protection of metallic materials against corrosion – Corrosion likelihood in soil – Part 2: Low alloyed and non alloyed ferrous materials
- EN 13438: Paints and varnishes – Powder organic coatings for galvanized or sherardised steel products for construction purposes
- EN 14199: Execution of special geotechnical works – Micropiles
- EN 14490: Execution of special geotechnical works – Soil nailing
- EN 15773: Industrial application of powder organic coatings to hot dip galvanized or sherardized steel articles [duplex systems] – Specifications, recommendations and guidelines
- ASTM A153: Standard Specification for Zinc Coating (Hot-Dip) on Iron and Steel Hardware
- ASTM A-775: Standard Specification for Epoxy-Coated Steel Reinforcing Bars
- ASTM A-934: Standard Specification for Epoxy-Coated Prefabricated Steel Reinforcing Bars
- ASTM D4435: Standard Test Method for Rock Bolt Anchor Pull Test
- DIN 21521-2: Rock bolts for mining and tunnel support; general specifications for steel-bolts; tests, testing methods
- ISRM: Suggested Methods for Rockbolt Testing
- Hollow Bar Soil Nails – Pullout Test Program. FHWA-CFL/TD-10-001. 2010
- European Technical Approval (ETA) as self-drilling rock and soil nail for temporary and permanent application: ETA-12/0603
- Approval for application as soil nail for temporary and semi-permanent application by the Austrian Federal Ministry of Transport, Innovation and Technology, Vienna, GZ: BMVIT-327.120/0012-IV/ST2/2015
- Approval for application as micropile for temporary and semi-permanent application by the Austrian Federal Ministry of Transport, Innovation and Technology, Vienna, GZ: BMVIT-327.120/0030-IV/IVS2/2015
- Designs and dimensions of system components as well as primary material specifications are included in DSI Underground's system brochures and approvals



System Accessories

DSI Underground provides a wide range of modular system accessories, which complete the premium quality series of the DYWI® Drill Hollow Bar System.

System accessories are essential for a safe and successful product performance. Typical system accessories can be used as structural load-bearing elements and for drilling, grouting, and monitoring.

Local support and short-term availability is provided by local competence centers – DSI Underground is THE SOLUTION PROVIDER.

- Yielding anchor head
- Angle compensation disks
- Reverse anchor head
- Protective caps
- Anchorage and foundation elements



- Bayonet connector



- Post-injection coupling



- Sleeves



- Utility nuts



- Injection flow-pressure meter



- Grout mixing pump



- Post-injection adapter
- Rotary injection adapter



System Accessories

- Drill rod wrench
- Rock drilling equipment

- Pull testing equipment

- Sealing coupling



- Lock coupling

- S-D expansion bolt

- Expansion shell

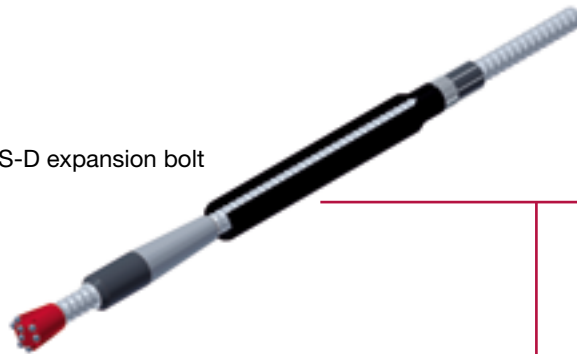

- Centralizer



- Drill bit adapters



- Drill bits



S-D Expansion Bolt

Introduction

In the past decade, various so-called “one-step” bolting systems have been developed. This is a result of steadily increasing requirements on installation procedures and the ensuing higher need for self-drilling bolts. The self-drilling bolt product family has now been extended by an expansion shell element for the DYWI® Drill Hollow Bar System.

This innovative DYWI® Drill S-D (self-drilling) expansion bolt is used both for Underground applications and in Civil Engineering. The key factor for the success of this combination bolt type

is the use of the long-term proven DYWI® Drill principle with a robust and innovative expansion element.

The DYWI® Drill S-D expansion bolt is installed self-drilling; borehole drilling and bolt installation are accomplished in one operational step. The system’s adaptability to changing ground conditions is an important feature. Immediately after the self-drilling installation, an activation of the expansion element leads to an instant load-bearing capacity. The DYWI® Drill S-D expansion bolt can be optionally tensioned following the fixation of

plate and nut. Subsequent grouting, de-coupled from the actual installation procedure, permits further optimization of installation cycle times.

One important application in Civil Engineering is the use in excavation pits, where the construction process requires an immediate load-bearing capacity. Underground, face support (face bolts) and longer vertical bolts (large-span support in caverns) are typical application examples for this type of self-drilling combination bolt.



System Description

- Expansion bolt: mechanically anchored and fully grouted
- Self-drilling installation based on the principle of the DYWI® Drill Hollow Bar System
- Hollow bar with continuous cold-rolled left-hand outside thread utilized as drill rod during installation
- Rotary-percussive installation using standard Underground drilling machines
- Conventional or automated installation
- Immediate load-bearing capacity via the mechanical end anchorage
- Subsequent optional grouting feature
- Flexible application range from 210 to 800 [kN] (47 - 180 [kip]): R32-210 to R51-800
- Utilization of several subsequently aligned extension expansion elements allows a higher load-bearing capacity even in weak ground

System Components

- Drill bit
 - Single-use drill bits in different diameters and designs
 - Hardened or carbide inserts
- S-D expansion element
 - Standard diameters: R32, R38, and R51
 - R38 and R51: several coupled extension expansion elements can be used
- Hollow bar R32, R38, or R51
- Plate
 - Different designs and dimensions available on request
- Nut
- Drive adapter
 - Couplings in different versions

S-D Expansion Bolt R38-076 with two Coupled Expansion Elements



S-D Expansion Bolt

Main Advantages

- Immediate load-bearing capacity after installation and activation of the expansion element
- Ability to maintain load-bearing capacity even when undergoing large deformations
- Improved drilling accuracy thanks to the directional guidance of the self-drilling expansion element
- Cycle time reduction due to the de-coupling of the grouting procedure from installation
- Tough system components
- Safe, easy, and reproducible installation procedure

Ready-For-Use S-D Expansion Bolt R32-051



Installation Procedure

- Assembly and connection of the drive adapter to the rock drill
- Rotary percussive self-drilling installation (counterclockwise rotation) without casing: single-use drill bit and hollow bar drill steel, water or air-water mixture flushing
- Optional extension using couplings
- Activation of the expansion element after the final drilling depth has been reached: withdrawal of the rock drill with hammer strokes
- De-coupling of the drive adapter
- Fixation and assembly of the anchorage (plate and nut)
- Optional de-coupled grouting



Expansion Shell

Introduction

Bolts with a variable free length ensure a pre-tensioning of the anchor and thus an active force transmission.

The DYWI® Drill expansion shell anchor is installed into pre-drilled boreholes. Immediate load-bearing capacity is achieved by an activation of the expansion shell.

The injection of the annular gap between the DYWI® Drill Hollow Bar tension member and the borehole using cement grout or DYWI® Inject Systems is accomplished in a second working step.

Main Advantages

- Simple handling and optimized installation time
- Immediate loading-bearing capacity
- Unproblematic installation in aquiferous boreholes
- The choice of the appropriate DYWI® Drill Hollow Bar ensures the optimum anchor force
- Continuous DYWI® Drill Hollow Bar thread allows flexible length adjustments and posterior extension on site
- Available for series R32, R38, and R51



Specifications

Characteristic Value / Type	Symbol	Unit	SK-R32-048	SK-R38-068	SK-R51-078
Nominal external diameter	$D_{e, nom}$	[mm]	48	68	78
		[in]	1.9	2.7	3.1
Length	L	[mm]	170	186	230
		[in]	6.7	7.3	9.1
Nominal weight	m	[kg]	1.8	4.0	7.8
		[lb]	4.0	8.8	17.2
Required borehole diameter	D_b	[mm]	52 - 58	72 - 78	90 - 95
		[in]	2.0 - 2.3	2.8 - 3.1	3.5 - 3.7
Nominal load-bearing capacity ¹⁾	$F_{m, nom}$	[kN]	230	400	630
		[kip]	52	90	142

1) Determined in the course of laboratory pull tests in model rock mass (concrete)

Installation Procedure

- Drilling of a borehole in accordance with the specifications, approx. 150 [mm] (6 [in]) longer than the expansion shell anchor when installed
- Insertion of the assembled expansion shell anchor into the borehole – shell must fit into the borehole tightly
- Pre-tensioning via impact screw driver or adequate driver tool
- Optional post grouting after installation

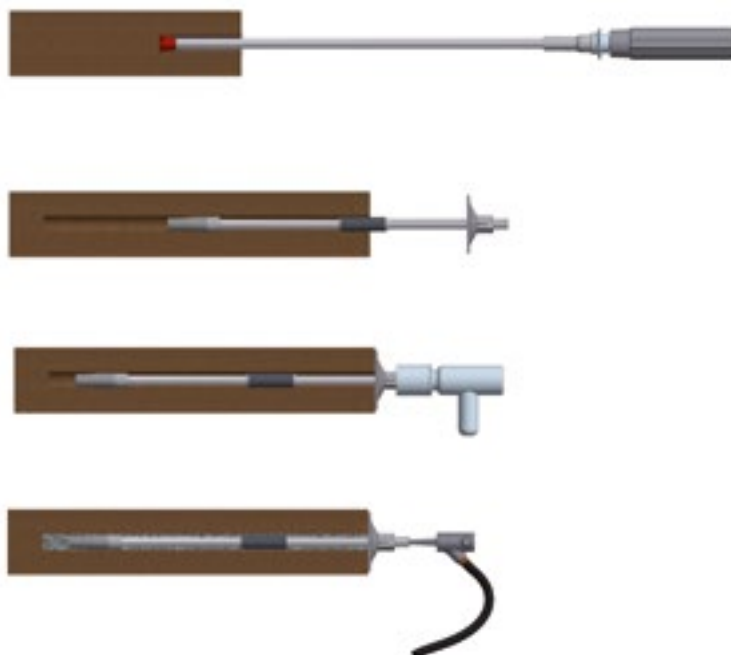

Yielding Anchor Head

Introduction

The DYWI® Drill yielding anchor head plus integrated free (de-bonded) length is used for applications in squeezing and loose ground. Installation is accomplished either self-drilling or in a pre-drilled borehole; the bond length is grouted.

Main Advantages

- Controlled accommodation of large deformations
- Adjustable to given ground conditions
- Constant high yielding force level
- Tough and durable design
- German approval for Underground application
- Simple and secure manipulation of pre-assembled components

Design Example DYWI® Drill Yielding Anchor



Specifications

Characteristic Value / Type	Unit	R32-GK 150-L ¹⁾
Yield force	[kN]	130 - 150
	[kip]	29 - 34
Yield length	[mm]	Up to 600
	[in]	Up to 23.6

1) Recommended default DYWI® Drill type: R32-360

Yielding Characteristics

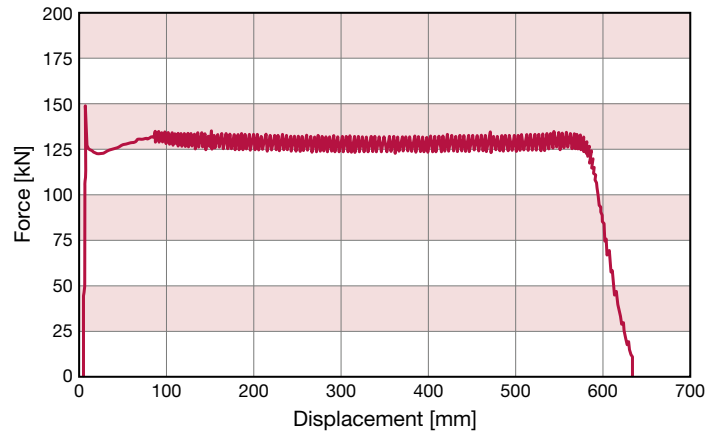

Basic Concept

Installation Principle

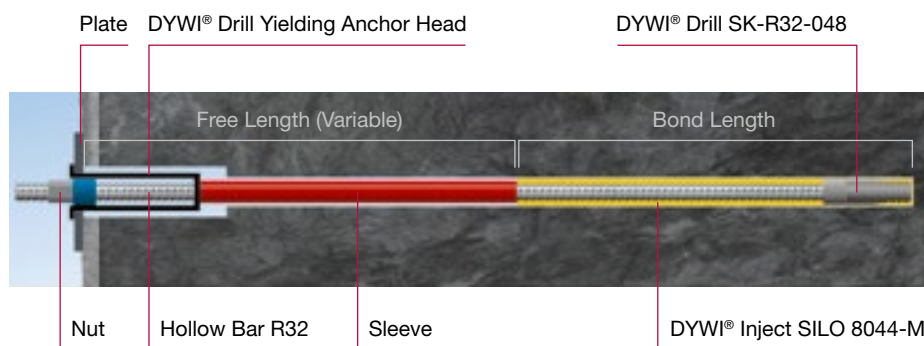

Working Mechanism

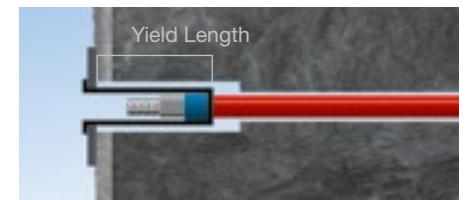

- Load transfer
 - Bond length: grouted, preferably in combination with an expansion shell
 - Anchorage: plate and yielding anchor head
- Working mechanism
 - Ground deformations result in an elongation of the hollow bar in the free length
 - Induced controlled yielding of the head construction
- Yielding anchor head
 - Discrete component
 - Absorbing mechanism based on a cylinder with integrated piston
 - Defined force-displacement characteristics
 - Adjustable to project-specific requirements

Lock Coupling

Introduction

When using standard couplings for installation, couplings inside the borehole may loosen due to hammer strokes applied in the course of drill string extension. There may be no external signs for this failure.

Faulty installation may be caused by worn out coupling adapters, damaged

or missing clamping jaws, or loose couplings if non system-conform components have been used.

The DYWI® Drill lock coupling prevents a loosening of couplings inside the borehole – the hollow bar is installed continuously in one piece.

Main Advantages

- The DYWI® Drill lock coupling does not detach itself during a clockwise rotation of the drill string
- Trouble-free extension or de-coupling of the drill string
- Suitable for free length sections
- Controlled removal of defined hollow bar sections by the selective use of standard couplings and lock couplings



System Description

The standard coupling is replaced by a DYWI® Drill lock coupling. During the counterclockwise rotation of the drill string, the inside locking mechanism (toothed gear with radial and longitudinal teeth) cuts transverse ribs onto the hollow bar. Thus, the hollow bar coupling is locked against clockwise rotation and loosening.

Specifications

- Available for series R32, R38, and R51
- Designed for highest load-bearing capacities
 - R32-400
 - R38-550
 - R51-800
- Optionally available with a one-sided or double locking mechanism

Technical Features

- Handling during installation is the same as for standard couplings
- The DYWI® Drill lock coupling permits rotary-percussive installation (counterclockwise) and locks the coupling during clockwise rotation of the drill string



Sealing Coupling

Introduction

Due to the design of conventional couplings for standard applications, absolute leak tightness of the couplings cannot be warranted when applying standard flushing pressures.

The DYWI® Drill sealing coupling allows an optimized installation procedure with regards to the leak tightness of the drill string. This advantage is significant for simultaneous drilling and injection operations.

Main Advantages

- Targeted and safe injection of the flushing and/or injection medium
- DYWI® Drill sealing couplings ensure leak tightness when applying standard flushing pressures
- Easy application; same operating principle as for standard couplings

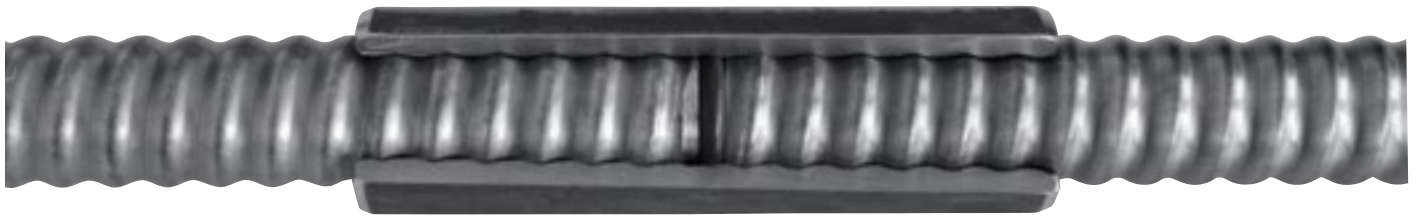

System Description

The standard coupling is replaced by a DYWI® Drill sealing coupling. Upon establishment of a proper and tight connection, the pre-installed centered sealing ring ensures a tight fitting between the chamfered surfaces of two hollow bars. During installation and injection, the DYWI® Drill sealing coupling ensures a tight connection under default working pressures.

Specifications

- Available for series R32, R38, R51, and T76
- Designed for highest load-bearing capacities
 - R32-400
 - R38-550
 - R51-800
 - T76-1900

Technical Features

- Handling during installation is the same as for standard couplings
- A sealing ring inside the coupling and chamfered hollow bar ends ensures optimum leak tightness



Post-Injection Coupling

Introduction

By default, the annular gap between hollow bar and ground is grouted via the outlet port at the drill bit to achieve improved load transmission.

The DYWI® Drill post-injection coupling allows the targeted post-injection through

the cleaned inner hole of the hollow bar using different injection media.

These injections can be carried out for ground improvement, sealing, or compensating grouting.

Main Advantages

- Application in all ground types
- No partial loss of drilling and cooling medium during installation
- Controlled and targeted post-injection of the ground
- Adjustable rated opening pressure



System Description

The standard coupling is replaced by a DYWI® Drill post-injection coupling. This special coupling type allows targeted multiple injections through circumferentially aligned injection holes with valves. Valve opening pressures can be adapted on customer request.

Specifications

- Available for series R32, R38, R51, and T76
- Designed for highest load-bearing capacities
 - R32-400
 - R38-550
 - R51-800
 - T76-1900
- Adjustable rated valve opening pressure: from 8 to 20 [bar] (115 to 290 [psi])

Technical Features

- Handling during installation is the same as for standard couplings
- The load-bearing capacity of the system (hollow bar - coupling) remains completely intact
- Multiple injections can be accomplished through valves with injection holes

Installation Procedure

- Assembly of the DYWI® Drill Hollow Bar System and connection to the rotary injection adapter
 - Note: self-drilling installation and subsequent grouting is also possible
 - Rotary self-drilling installation and simultaneous grouting
 - Primary injection process through the drill bit
 - Extension of hollow bars with DYWI® Drill post-injection couplings
 - Post-injection and final assembly
 - Flushing of the injection channel (inside of the hollow bar) with water using a plastic hose shortly after the installation is completed
 - Short curing time primary injection, depending on the grout mixture used (generally 12 to 18 hours)
 - Post-injection with an injection adapter through the DYWI® Drill post-injection couplings
- with a pressure exceeding 8 [bar] (115 [psi])
- Maximum injection pressure depending on application and ground conditions
 - Repetition of working steps in case a consecutive injection process is required
 - Preparation of the head construction, if required

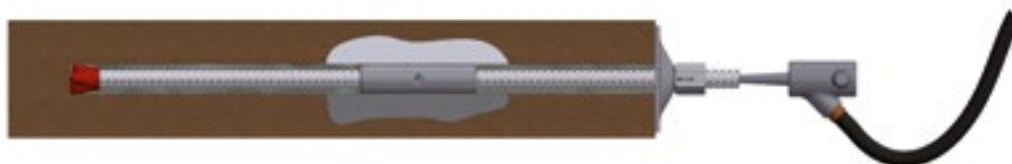

Utility Nuts

Loop and Eye Nut

- Eye nut: heavy duty version
- Loop nut: standard version
- Utility hangers
- Fixation of ropes and mats
- Anchorage of mesh and geogrid



Bail Nut

- Light utility hangers
- Mounting of instrumentation tools



Anchorage Elements

Sleeves

- De-bonding
- Free length(s)
- Additional corrosion protection
- Micropiles: pile neck reinforcement
- Steel and plastic versions available



Protective Caps

- Temporary corrosion protection
- Construction walls where shotcrete is not used for sealing
- Protection of personnel when head constructions are exposed to walkways
- Steel and plastic versions available



Anchorage Elements

Angle Compensation Disks

- Secure anchorage even when undergoing large inclinations
- Standard application in combination with domed nuts
- Standard version for hollow bar series R32 and R38



Reverse Anchor Head

- Sheet piles
- Tie-back anchorage
- Limited space conditions



Rock Drilling Equipment

System Components

- Shank adapters
- Couplings
- Adapter couplings
- Extension drilling equipment
- Coupling adapters
- Drill bits
 - Drill bits in either flat face or retrac design
 - Cross drill bits
- Further information is included in the section rock reinforcement

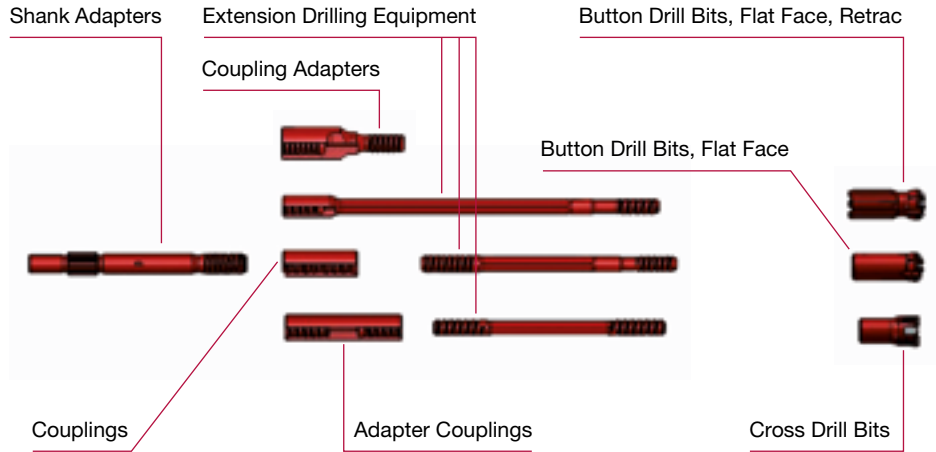

Drill Bit Adapters

- Connection of hollow bar and drill bit threads of different diameters
- Large drill bit portfolio for diameter ranges outside standard versions
- Controlled transmission of the drilling energy from the hollow bar onto the drill bit



Drill Rod Wrench and Tensioning Tool

- Tough design
- Various lengths and wrench sizes

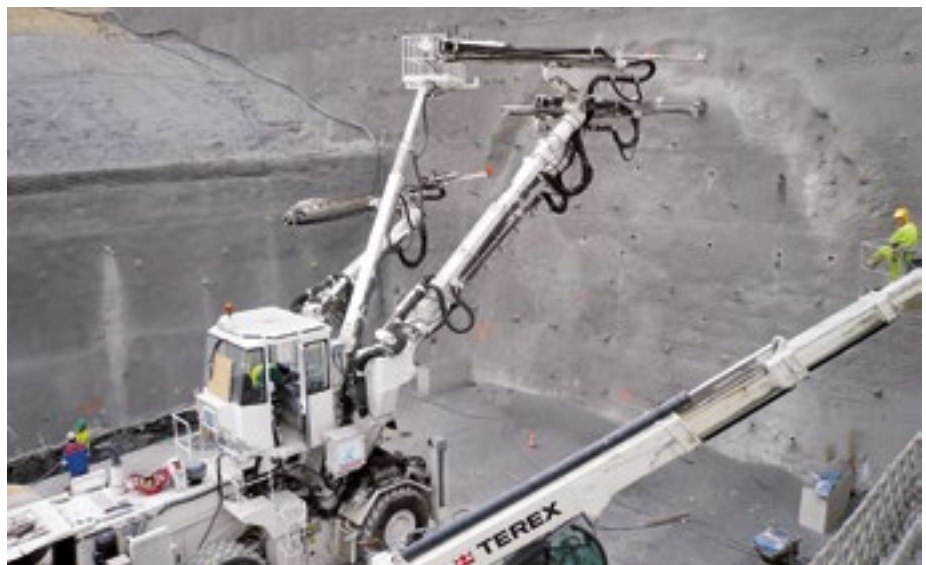

Rock Drilling Equipment

Bayonet Connector

The bayonet connector is a sealed, easy-to-remove connection between hollow bars used for self-drilling installation. It consists of two parts: adapter and coupling. A bayonet connector efficiently transfers the total impact energy and torque from the hydraulic drifter or rotary head onto the hollow bar drill string. Defined hollow bar sections can be easily removed once drilling has been completed.

- Sealed connection for micropile installation
- Easy to disconnect
- Removal of defined hollow bar sections
- Transfer of the drilling energies nearly without any loss



Centralizers

- Centralization of DYWI® Drill Hollow Bars inside the borehole
- Increased directional installation accuracy
- Optimum grout cover
- Available for series R32, R38, R51, and T76

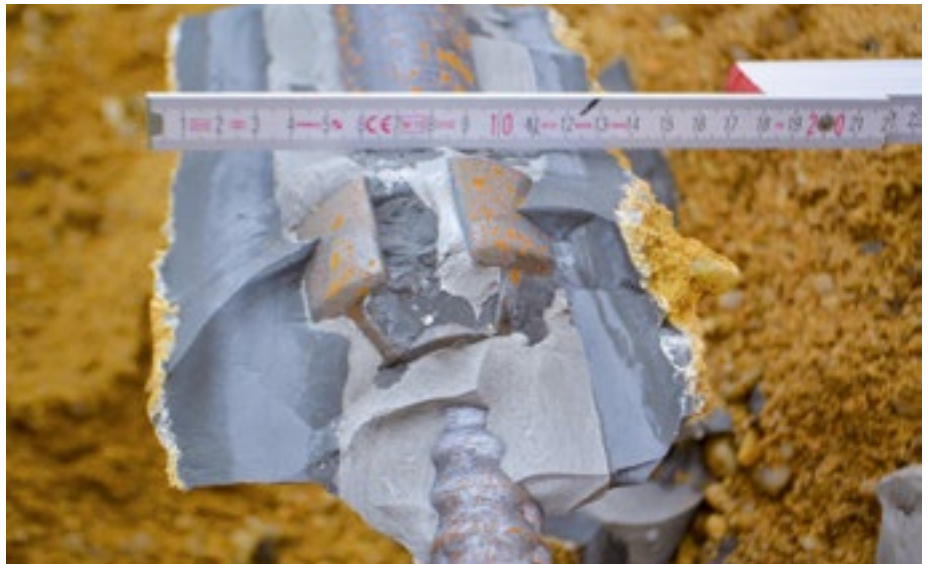

Injection Adapters

Rotary Injection Adapter

System Components

- Flushing head housing
- Flushing shaft with connecting thread for the hollow bar and the shank adapter
- Gasket and wiper (internal)
- Fixing bracket with connection thread for the injection hose
- Grease fitting
- Dampening rubber

Main Advantages

- Simultaneous drilling and grouting ensures an ideal bond with the loose rock or soil
- Penetration of the injection material into the surrounding ground
- Ground improvement and homogeneous distribution of the injection material

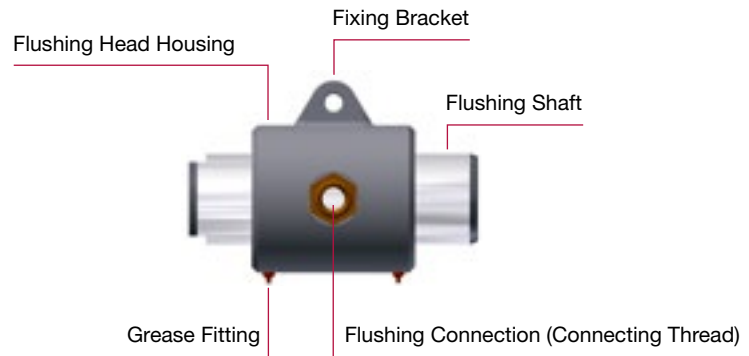

Injection Adapter

- Different versions for cement grout or resin injection
- Conical push adapters or threaded adapter couplings
- Various grout hose connections available on request

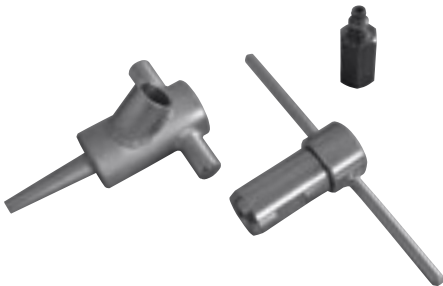

Grout Mixing Pump

Introduction

DSI MAI® grout mixing pumps have been developed for extremely challenging Underground conditions. They have been successfully used around the world in Tunneling and Civil Engineering, for example for the shoring of slopes, hill sides, and building excavations.

The proven and delivery technology is suitable for:

- Injection and grouting works
- Re-injection
- Drillhole filling
- Backfilling

Further information regarding DSI MAI® grout mixing pumps is included in the section cement injection.

Main Advantages

- Tough design and galvanized pump casing
- Low empty weight
- Simple operation and maintenance due to modular design
- Low start-up and cleaning times
- Low filling and overall height
- High delivery rate at continuous pressure
- Variable discharge
- All-purpose equipment



Injection Flow-Pressure Meter

Introduction

The revolutionary injection flow-pressure meter DSI MAI® LOG400 permits an exact and comprehensible

documentation of ground improvement as well as a control system for specified injection termination criteria.

Further information regarding DSI MAI® LOG400 injection flow-pressure meters is included in the section cement injection.

System Description

Flow rates and injection pressures are recorded separately for each injection borehole. The manipulation-proof digital data recording is operated via a user-friendly and simple touch-screen terminal. The easy handling and the integrated software, which allows the input of the working data into spreadsheet calculation program, are a benefit for each job site.

System Components

- Flow meter
- Pressure transmitter
- Operating and analysis unit
- Data transfer via compact flash card or USB
- Tripod
- Technical documentation
- User manual
- Software package







Passive Support

Fields of Application

Steel Ribs

Steel ribs are efficient and safe ground control elements in Tunneling. Selection of section type and dimension is accomplished in accordance with structural and project requirements. In addition to custom-bent steel ribs, straight beams, forepoling sheets, and steel lagging can also be fabricated.

DSI Underground has manufactured cold-formed beams for Underground support applications since 1922,

applying sound techniques for shaping steel required in the Tunneling industry.

Techniques learned about shaping steel for strength, performance, and value in the world's tunnels and shafts can be applied to the benefit for each project.

- Tunnel ribs
- Shaft rings and breakout structures
- Mine sets and overcasts
- Steel lagging

Liner Plates

- Ground support in conventional excavation
- Soft ground Tunneling
- Vertical and inclined tunnels
- TBM and MTBM jacking load resistance system
- Shaft and cofferdam support
- Smooth liner plates: shield excavation or tunnel boring machines
- Gasketed liner plates: hydrostatic conditions and reduction of water inflow
- Tapered liner plates: used for changes in alignment, both horizontal and vertical

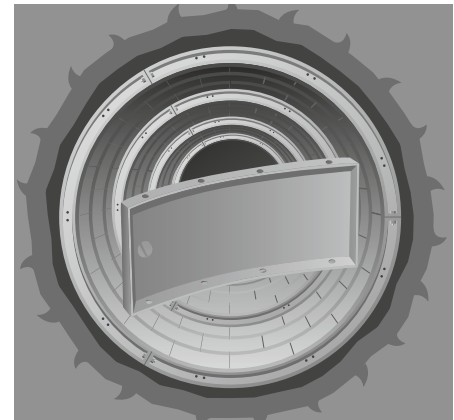

Lattice Girders

- SEM/NATM excavation
- Passive support system for the excavated cross section
- Profile template for the excavation geometry
- Bearing for pre-support elements

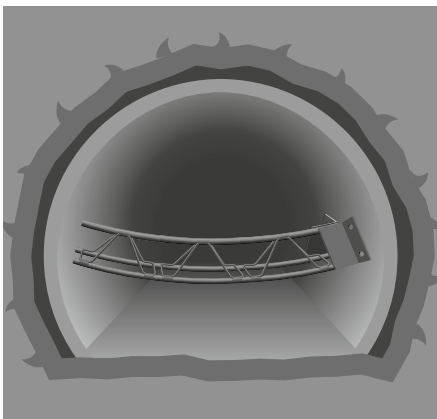

BULLFLEX® Support System

- Support pillars
- Roof support backfilling
- Roadway packs and dams
- Structural bulkheads
- Stoppings
- Structural sealings

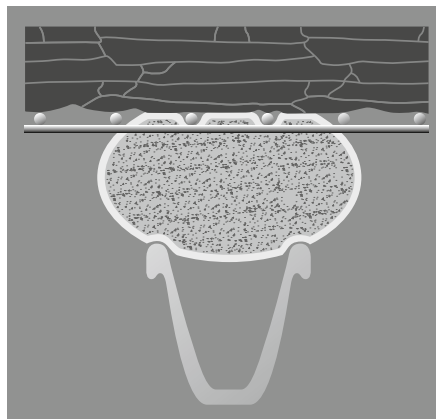

LSC™ Elements

- Weak ground combined with high overburden
- Large displacements
- Fault zones
- Swelling ground
- Squeezing ground

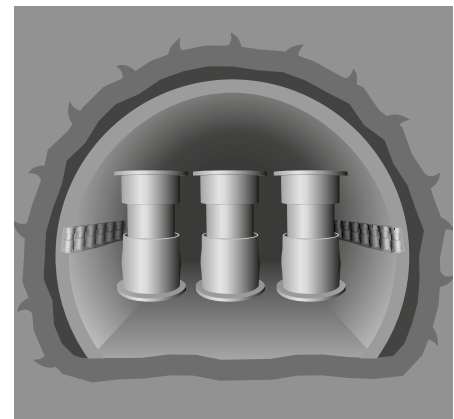

Passive Support

Contents

Steel Ribs	62
Liner Plates	66
PANTEX Lattice Girders	76
BULLFLEX® Support System	84
LSC™ Elements	92

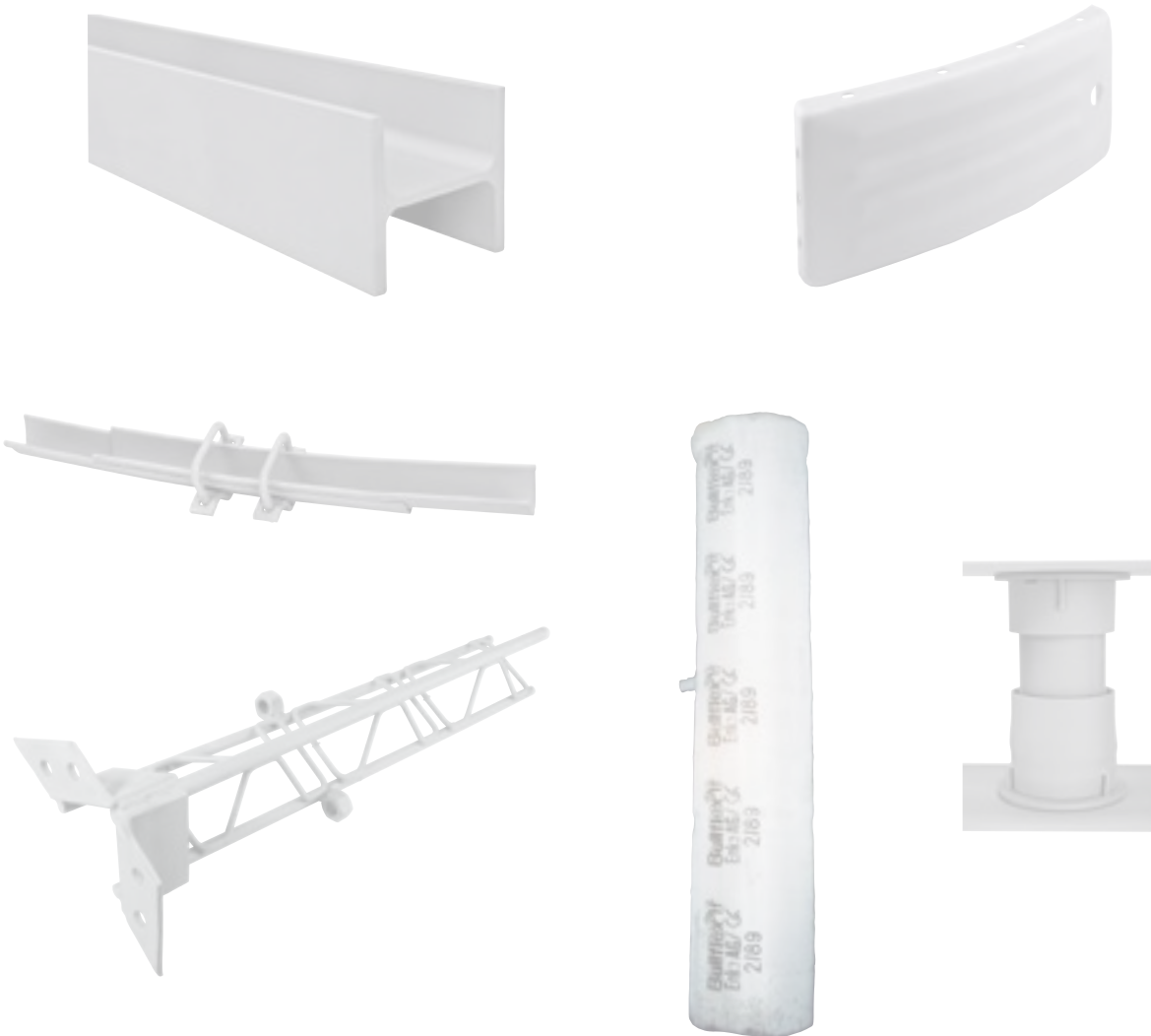

Steel Ribs



Tunnel Ribs



Shaft Rings and Breakout Structures



Mine Sets and Overcasts



Steel Lagging

Main Advantages

- Customized cold-formed beam constructions
- Various rib support types available on request
- Flexible adaptation of the beam geometry to the respective excavated cross-section
- TH sections and other special support profiles available on request
- Custom formed lagging resistant to machine jack thrusts and impact loads

Steel Rib Support Types

- Type 1:
2 pcs. horseshoe with optional invert strut

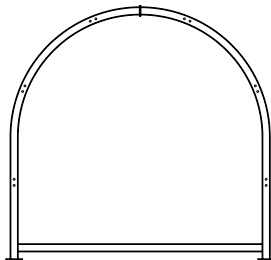

- Type 2:
4 pcs. modified horseshoe

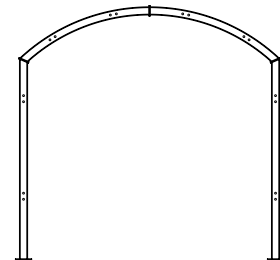

- Type 3:
4 pcs. horseshoe

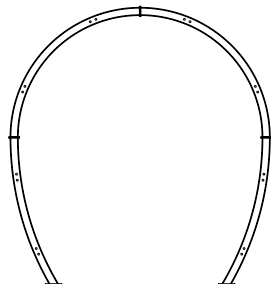

- Type 4:
3 pcs. circular

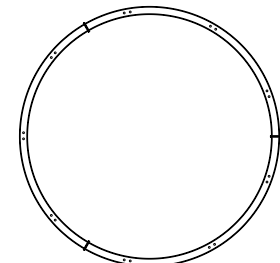

Steel Ribs

Specifications SI Units

TH Profile

- Mine support steel 31Mn4 according to DIN 21544
- Bent to the corresponding profile
- Single overlapping segments are usually connected by two locks
- Alternative TH locks are available on request

Characteristic Value / Type	Symbol	Unit	TH 21	TH 25	TH 29	TH 36
Nominal weight	m	[kg/m]	21	25	29	36
Profile height	H	[mm]	108	118	124	138
Profile width	B	[mm]	124	135	151	171
Neutral axis	e	[mm]	52	58	58	69
Section modulus	W_x	[cm ³]	61	80	94	136

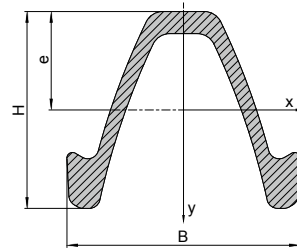

HEB Profile

- I profile – broad flange girder
- Primary material S235JRG2 or S355J2G3 according to EN 10025-2
- Bent to the corresponding profile
- Connection of the segments via head plates that are available in different designs
- Alternative connection of the abutting segments via laces
- Different lace types and lace screws are available on request

Characteristic Value / Type	Symbol	Unit	HEB 100	HEB 120	HEB 140
Nominal weight	m	[kg/m]	20.9	27.4	34.5
Profile height	H	[mm]	100	120	140
Profile width	B	[mm]	100	120	140
Section modulus	W_x	[cm ³]	89.9	144.0	216.0
	W_y	[cm ³]	33.5	52.9	78.5

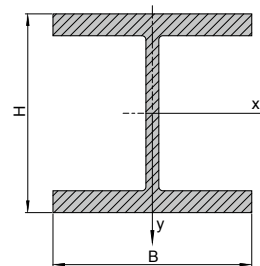

UNP Profile

- U profile – flanges with inclined inner surfaces
- Primary material S235JRG2 or S355J2G3 according to EN 10025-2
- Bent to the corresponding profile
- Connection of the segments via welded-on and screwed head plates or flange connections
- Different lace types and lace screws are available on request

Characteristic Value / Type	Symbol	Unit	UNP 80	UNP 100	UNP 120	UNP 140	UNP 160	UNP 180
Nominal weight	m	[kg/m]	8.6	10.6	13.4	16.4	18.8	22.0
Profile height	H	[mm]	80	100	120	140	160	180
Profile width	B	[mm]	45	50	55	60	65	70
Neutral axis	e	[cm]	1.45	1.55	1.60	1.75	1.84	1.92
Section modulus	W_y	[cm ³]	6.4	8.5	11.1	14.8	18.3	22.4

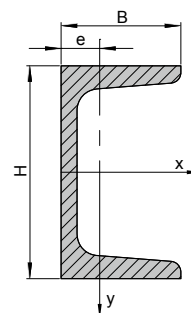

Steel Ribs

Specifications US Customary Units

- Butt joints
 - Height: rib depth plus 1"
 - Width: flange width plus 1"
- Tie rods
 - ASTM A529 \varnothing $\frac{3}{4}$ " rod stock with 4" NC threaded each end
 - Length: rib spacing plus 6"
 - Beam width 12" and above: structural spreaders are recommended
- Pipe spacers
 - Schedule 40 pipe stock \varnothing 2" (for \varnothing $\frac{3}{4}$ " tie rods)
 - Length: rib spacing minus web thickness



Joints and Foot Plates

Characteristic Value	Unit	4"	5"	6"	8"	10"	12"
Butt joint thickness	[in]	3/8	3/8	1/2	5/8	3/4	1
Bolt quantity ¹⁾	[1]	2	2	2	4	4	6
Bolt diameter ¹⁾	[in]	3/4	1	1	1	1	1
Foot plate dimensions	[in]	$\frac{1}{2}$ " x 7" x 7"	5/8" x 9" x 9"	5/8" x 9" x 9"	$\frac{3}{4}$ " x 12" x 12"	1" x 14" x 14"	1 $\frac{1}{4}$ " x 16" x 16"

1) ASTM A325. For standard loading conditions; higher loads may require a full-moment strength joint



Steel Ribs

Characteristics

- Curvature range: minimum radius of 10 times the beam depth for 4" and 6" sections up and to 14 times for larger beams
- I, WF, and H sections from 4" to 27" (102 to 686 [mm]) in depth, bent to project requirements

Steel Lagging (North America)

- Custom-formed as a replacement for wood lagging
- Placement on the inside or outside flange
- Low profile and high profile types
- Lagging clamp: 3" x 5" x 5" gage with square or round hole
- 5/8" diameter carriage bolt with nut

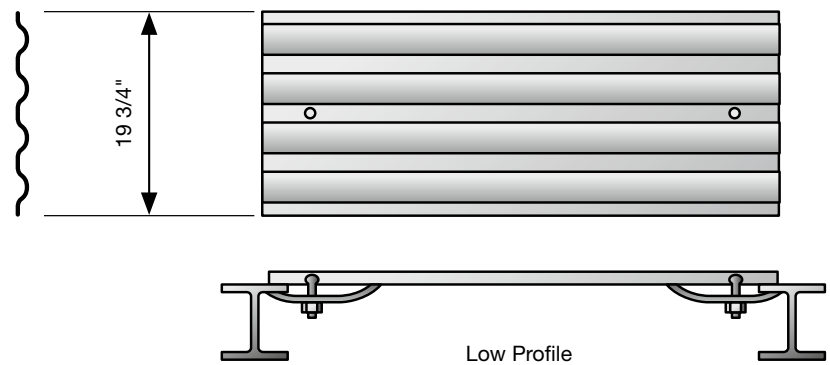
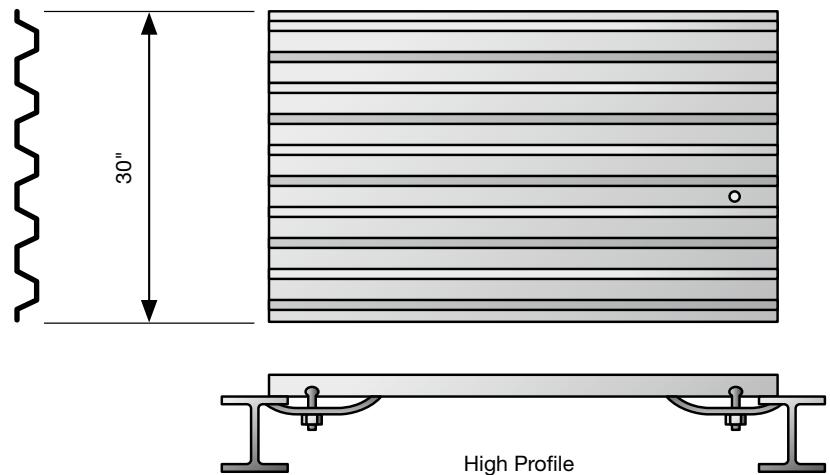
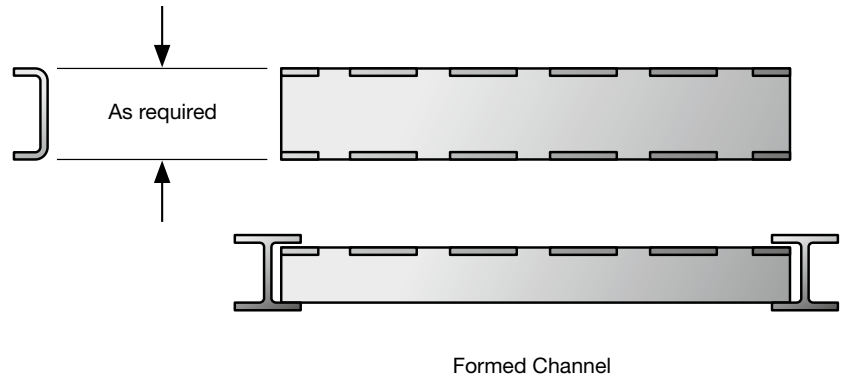

Liner Plates

Introduction

4-flange steel liner plates, a system which has been successfully used since 1926, provide light-weight, easy-to-handle, and safe support for soft ground Tunneling and shaft construction made in the USA (Louisville, Kentucky).

4-flange liner plates manufactured by DSI Underground are available in 400 and 610 [mm] (16" and 24") widths as corrugated or smooth plates. Liner plates are formed from one piece of steel to provide longitudinal and

circumferential flanges with optimum load-bearing and bending resistance characteristics.

4-flange liner plates can be galvanized, bitumen coated, and polymer coated. Grout holes and plugs can also be coated. For special conditions, gasketed liner plates and tapered liner plates can also be manufactured. Liner plates are installed as stand alone structures or in conjunction with steel ribs if additional support is required.

Diameters of tunnels and shafts supported solely with 4-flange liner plates can vary from 1.2 to 6.1 [m] (4" to 20").

The liner plate assembly simply distributes and transmits the load to the surrounding ground. As a steel liner plate ring takes load vertically, it tends to deflect inward at the top and outward at the sides. Thereby, the ground resists deflection of the lining by developing a passive force equal in magnitude and opposite in direction to the force exerted by that of the lining.



Main Advantages

- Optimized cycle times and manpower requirements
- Maximum consistent passive support strength with minimum weight of steel
- Safe support system
- Easy to store, handle, and erect
- Flexible design for different tunnel geometries and ground conditions
- Fire resistant system components
- Optional gasket plates for sealing of joints available on request
- DSI Underground's 4-flange smooth liner plates are the only liner plate type capable of resisting tunnel boring machine jacking loads without any supplemental structural support

Liner Plates

System Description

4-flange steel liner plates provide a relatively light-weight, easy-to-handle, and safe support for soft ground Tunneling, because the ground that supplies the loading also supplies the respective resistance. The liner plate assembly simply distributes and transmits the load to the surrounding ground. As a steel liner plate ring takes load vertically, it tends to deflect inward at the top and outward at the sides. The ground resists deflection of the lining by developing a passive force equal in magnitude and opposite in direction to the force exerted by that of the lining.

The ability of the surrounding ground to resist the outward bulge of the liner plate ring is the key to vertical load support. With the ring confined to a small amount of deflection, the thrust line induced by the load is forced to follow the ring of liner plates. Thus, the ability of the assembly to withstand the applied load depends upon its ability to transmit ring thrust from plate to plate around the ring. Obviously, this ability is enhanced by the four-flange design of DSI Underground.

There are various methods for determining the required strength of tunnel linings. Type of ground, location and depth of cover, size and length of the tunnel, level of ground water, superimposed loading, and history always guide these calculations.

Designs from DSI Underground conform to the latest guidance of AASHTO (American Association of State Highway and Transportation Officials) and AREMA (The American Railway Engineering and Maintenance-of-Way Association).

Diagram of Load and Load Reactions

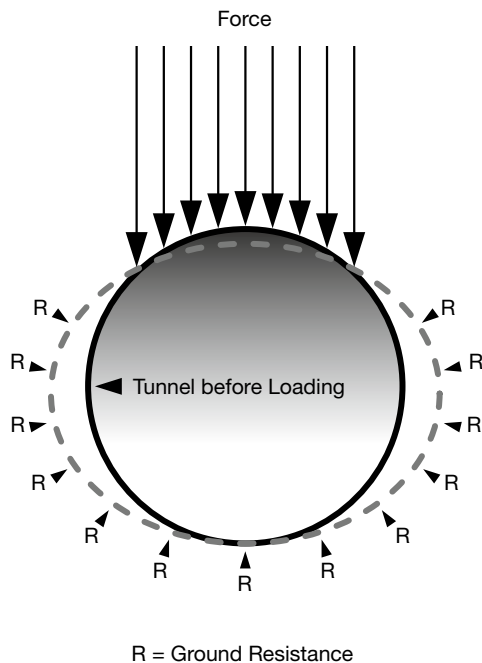

System Components

- Cold-formed 4-flange steel liner plates, 406 and 610 [mm] (16" and 24") widths
- Thicknesses of 12, 10, 8, 7, 5, 3 gages (gauges), 5/16", or 3/8" (8 or 9.5 [mm]) available
- Corrugated or smooth plate, steel grade according to ASTM A1011
- Galvanized (ASTM A 123) and/or bitumen coated (AASHTO M190) versions available
- Customized partial plates are available to meet specific dimensions
- Liner plate gaskets and 51 [mm] (2") grout holes available on request
- Bolts and nuts with quick acting coarse thread according to ASTM A 307 (hot-dip galvanized: ASTM A 153)
- Polymer coating according to the aerospace standard SAE AS1003

Liner Plates

Specifications

Permissible Safe Loads on Circular Tunnels of Various Diameters or Arches for 16" Wide Corrugated Liner Plates ¹⁾

SI Units									US Customary Units								
Safe Load Table (Loads in [kN/m ²])									Safe Load Table (Loads in [psf])								
Thickness [mm]	12 gage	10 gage	8 gage	7 gage	5 gage	3 gage	5/16"	3/8"	Thickness [in]	12 gage	10 gage	8 gage	7 gage	5 gage	3 gage	5/16"	3/8"
Diameter [m]	2.66	3.42	4.18	4.55	5.31	6.07	7.94	9.53	Diameter [ft]	0.1046	0.1345	0.1644	0.1793	0.2092	0.2391	0.3125	0.375
1.2	208	342	399	431	530	602	776	925	4	4,335	7,135	8,335	9,000	11,075	12,580	16,200	19,320
1.5	166	273	319	345	424	482	621	740	5	3,465	5,710	6,665	7,200	8,860	10,065	12,960	15,455
1.8	138	228	266	287	353	401	517	617	6	2,890	4,755	5,555	6,000	7,380	8,385	10,800	12,880
2.1	119	195	228	246	303	344	443	529	7	2,475	4,080	4,760	5,145	6,325	7,190	9,260	11,040
2.4	104	171	199	215	265	301	388	463	8	2,165	3,570	4,165	4,500	5,535	6,290	8,100	9,660
2.7		143	177	192	236	268	345	411	9		2,985	3,705	4,000	4,920	5,590	7,200	8,585
3.0		111	147	160	202	225	310	370	10		2,310	3,080	3,350	4,220	4,705	6,480	7,730
3.4			114	124	161	179	258	323	11			2,380	2,590	3,370	3,735	5,380	6,755
3.7				96	126	139	207	265	12				1,995	2,635	2,900	4,330	5,535
4.0					99	109	164	213	13					2,070	2,280	3,420	4,445
4.3					79	87	131	170	14					1,660	1,825	2,740	3,560
4.6							107	139	15							2,225	2,895
4.9								114	16							1,835	2,385
5.2							73	95	17							1,530	1,990
5.5								80	18								1,675
5.8								68	19								1,425
6.1								58	20								1,220

1) Note: 4-flange liner plates for tunnel diameters other than those shown in the tables are available. Please refer to DSI Underground engineering staff for a safe load determination outline

Sectional Properties for 16" Wide Corrugated Liner Plates

SI Units													
Plate Thickness		Dimensions			Theoretical Area		Effective Area	Moment of Inertia		Radius of Gyration	Weight		
Gage	Decimal	X	Y	Side Flange	[mm ²]	[mm ² /mm]	[mm ² /mm]	[mm ⁴]	[mm ⁴ /mm]	[mm]	Full Plate	Half Plate	
	[mm]	[mm]	[mm]	[mm]							[kg]	[kg]	
12	2.7	16	49	51	1,372	3.4	1.73	2,816,166	693	14.2	11.0	5.9	
10	3.4	16	49	51	1,754	4.3	2.21	3,657,769	900	14.5	14.2	7.5	
8	4.2	17	51	54	2,158	5.3	2.72	4,945,563	1,218	15.2	17.3	9.3	
7	4.6	17	51	54	2,346	5.8	2.95	5,395,917	1,327	15.2	18.6	9.8	
5	5.3	18	54	57	2,721	6.7	3.43	7,195,666	1,771	16.3	22.0	11.9	
3	6.1	18	53	57	3,092	7.6	3.89	7,969,008	1,962	16.0	24.9	13.1	
5/16"	7.9	19	55	60	3,982	9.8	5.01	11,828,229	2,910	17.3	31.1	16.4	
3/8"	9.5	23	55	64	4,748	11.7	5.98	15,408,581	3,792	18.0	37.3	19.6	

US Customary Units													
Plate Thickness		Dimensions			Theoretical Area		Effective Area	Moment of Inertia		Radius of Gyration	Weight		
Gage	Decimal	X	Y	Side Flange	[in ²]	[in ² /in]	[in ² /ft]	[in ⁴]	[in ⁴ /in]	[in]	Full Plate	Half Plate	
	[in]	[in]	[in]	[in]							[lb]	[lb]	
12	0.10	0.61	1.95	2.00	2.13	0.13	0.80	0.68	0.04	0.56	24.2	12.9	
10	0.13	0.62	1.95	2.00	2.72	0.17	1.02	0.88	0.05	0.57	31.2	16.5	
8	0.16	0.66	2.02	2.13	3.34	0.21	1.25	1.19	0.07	0.60	38.2	20.6	
7	0.18	0.66	2.02	2.13	3.64	0.23	1.36	1.30	0.08	0.60	40.9	21.7	
5	0.21	0.70	2.12	2.25	4.22	0.26	1.58	1.73	0.11	0.64	48.6	26.2	
3	0.24	0.72	2.09	2.25	4.79	0.30	1.80	1.91	0.12	0.63	54.9	28.9	
5/16"	0.31	0.76	2.17	2.38	6.17	0.39	2.31	2.84	0.18	0.68	68.6	36.1	
3/8"	0.38	0.91	2.15	2.50	7.36	0.46	2.76	3.70	0.23	0.71	82.3	43.3	

Liner Plates

Specifications

Permissible Safe Loads on Circular Tunnels of Various Diameters or Arches for 16" Wide Smooth Liner Plates ¹⁾

SI Units									US Customary Units								
Safe Load Table (Loads in [kN/m ²])									Safe Load Table (Loads in [psf])								
Thickness [mm]	12 gage	10 gage	8 gage	7 gage	5 gage	3 gage	5/16"	3/8"	Thickness [in]	12 gage	10 gage	8 gage	7 gage	5 gage	3 gage	5/16"	3/8"
Diameter [m]	2.66	3.42	4.18	4.55	5.31	6.07	7.94	9.53	Diameter [ft]	0.1046	0.1345	0.1644	0.1793	0.2092	0.2391	0.3125	0.375
1.2	208	329	399	431	517	587	766	919	4	4,335	6,870	8,335	9,000	10,800	12,265	15,995	19,195
1.5	166	263	319	345	414	470	613	735	5	3,465	5,495	6,665	7,200	8,640	9,815	12,795	15,355
1.8	138	219	266	287	345	391	511	613	6	2,890	4,580	5,555	6,000	7,200	8,175	10,665	12,795
2.1		184	228	246	295	336	438	525	7		3,850	4,760	5,145	6,170	7,010	9,140	10,970
2.4			187	204	256	290	383	460	8			3,915	4,255	5,340	6,065	8,000	9,600
2.7			139	151	196	223	313	407	9			2,905	3,160	4,095	4,650	6,545	8,490
3.0					146	165	240	322	10					3,045	3,455	5,020	6,735
3.4					109	124	181	249	11					2,285	2,595	3,780	5,210
3.7						96	139	192	12						2,000	2,910	4,010
4.0							110	151	13							2,290	3,155
4.3							88	121	14							1,835	2,525
4.6								98	15								2,055
4.9								81	16								1,690
5.2								68	17								1,410
5.5									18								
5.8									19								
6.1									20								

1) Note: 4-flange liner plates for tunnel diameters other than those shown in the tables are available. Please refer to DSI Underground engineering staff for a safe load determination outline

Sectional Properties for 16" Wide Smooth Liner Plates

SI Units												
Plate Thickness		Dimensions			Theoretical Area		Effective Area	Moment of Inertia		Radius of Gyration	Weight	
Gage	Decimal	X	Y	Side Flange	[mm ²]	[mm ² /mm]	[mm ² /mm]	[mm ⁴]	[mm ⁴ /mm]	[mm]	Full Plate	Half Plate
	[mm]	[mm]	[mm]	[mm]							[kg]	[kg]
12	2.7	6	45	51	1,321	3.3	1.7	140,936	347	11.7	11.0	5.9
10	3.4	7	44	51	1,689	4.2	2.1	230,759	567	11.7	14.2	7.5
8	4.2	7	46	54	2,078	5.1	2.6	330,654	814	12.7	17.3	9.3
7	4.6	8	46	54	2,260	5.6	2.8	357,251	878	12.7	18.6	9.8
5	5.3	9	49	57	2,654	6.5	3.3	484,785	1,193	13.5	22.0	11.9
3	6.1	9	48	57	3,015	7.4	3.8	544,556	1,340	13.5	24.9	13.1
5/16"	7.9	10	50	60	3,931	9.7	5.0	803,077	1,976	14.2	31.1	16.4
3/8"	9.5	12	52	64	4,718	11.6	5.9	1,088,112	2,678	15.2	37.3	19.6

US Customary Units												
Plate Thickness		Dimensions			Theoretical Area		Effective Area	Moment of Inertia		Radius of Gyration	Weight	
Gage	Decimal	X	Y	Side Flange	[in ²]	[in ² /in]	[in ² /ft]	[in ⁴]	[in ⁴ /in]	[in]	Full Plate	Half Plate
	[in]	[in]	[in]	[in]							[lb]	[lb]
12	0.10	0.25	1.75	2.00	2.05	0.13	0.77	0.34	0.02	0.46	24.2	12.9
10	0.13	0.26	1.74	2.00	2.62	0.16	0.98	0.55	0.03	0.46	31.2	16.5
8	0.16	0.30	1.83	2.13	3.22	0.20	1.21	0.79	0.05	0.50	38.2	20.6
7	0.18	0.30	1.82	2.13	3.50	0.22	1.31	0.86	0.05	0.50	40.9	21.7
5	0.21	0.34	1.91	2.25	4.11	0.26	1.54	1.16	0.07	0.53	48.6	26.2
3	0.24	0.35	1.90	2.25	4.67	0.29	1.75	1.31	0.08	0.53	54.9	28.9
5/16"	0.31	0.41	1.97	2.38	6.09	0.38	2.29	1.93	0.12	0.56	68.6	36.1
3/8"	0.38	0.46	2.04	2.50	7.31	0.46	2.74	2.61	0.16	0.60	82.3	43.3

Liner Plates

Specifications

Permissible Safe Loads on Circular Tunnels of Various Diameters or Arches for 24" Wide Corrugated Liner Plates ¹⁾

SI Units									US Customary Units								
Safe Load Table (Loads in [kN/m ²])									Safe Load Table (Loads in [psf])								
Thickness [mm]	12 gage	10 gage	8 gage	7 gage	5 gage	3 gage	5/16"	3/8"	Thickness [in]	12 gage	10 gage	8 gage	7 gage	5 gage	3 gage	5/16"	3/8"
Diameter [m]	2.66	3.42	4.18	4.55	5.31	6.07	7.94	9.53	Diameter [ft]	0.1046	0.1345	0.1644	0.1793	0.2092	0.2391	0.3125	0.375
1.2 ²⁾	208	315	385	419	490	556	722	862	4 ²⁾	4,335	6,570	8,045	8,750	10,230	11,615	15,075	18,000
1.5	166	252	308	335	392	445	577	689	5	3,465	5,255	6,440	7,000	8,185	9,295	12,060	14,400
1.8	138	210	257	279	327	371	481	575	6	2,890	4,380	5,365	5,830	6,820	7,745	10,050	12,000
2.1	119	180	220	239	280	318	412	492	7	2,475	3,755	4,600	5,000	5,845	6,640	8,615	10,285
2.4		149	193	209	245	278	361	431	8		3,115	4,025	4,375	5,115	5,810	7,535	9,000
2.7			154	163	209	237	321	383	9			3,215	3,410	4,365	4,955	6,700	8,000
3.0			117	123	163	185	259	328	10			2,440	2,560	3,410	3,870	5,410	6,855
3.4					124	141	202	262	11					2,595	2,945	4,225	5,480
3.7					96	109	156	205	12					2,000	2,270	3,255	4,280
4.0							123	161	13							2,560	3,365
4.3							98	129	14							2,050	2,695
4.6							80	105	15							1,665	2,190
4.9								86	16								1,805
5.2								72	17								1,505
5.5									18								
5.8									19								
6.1									20								

1) Note: 4-flange liner plates for tunnel diameters other than those shown in the tables are available. Please refer to DSI Underground engineering staff for a safe load determination outline

2) Not recommended for circular tunnel applications

Sectional Properties for 24" Wide Corrugated Liner Plates

SI Units													
Plate Thickness		Dimensions			Theoretical Area		Effective Area	Moment of Inertia		Radius of Gyration	Weight		
Gage	Decimal	X	Y	Side Flange	[mm ²]	[mm ² /mm]	[mm ² /mm]	[mm ⁴]	[mm ⁴ /mm]	[mm]	Full Plate	Half Plate	
	[mm]	[mm]	[mm]	[mm]							[kg]	[kg]	
12	2.7	15	52	51	1,895	3.1	1.6	325,992	534	13.2	15.6	8.5	
10	3.4	15	52	51	2,421	4.0	2.0	412,485	677	13.0	20.0	10.7	
8	4.2	16	54	54	2,967	4.9	2.5	569,529	934	14.0	23.9	12.9	
7	4.6	16	54	54	3,225	5.3	2.7	616,605	1,011	13.7	25.8	13.9	
5	5.3	17	56	57	3,772	6.2	3.2	810,111	1,329	14.7	31.1	16.8	
3	6.1	17	56	57	4,283	7.0	3.6	912,920	1,498	14.7	36.4	19.6	
5/16"	7.9	19	58	60	5,557	9.1	4.7	1,313,751	2,155	15.5	46.1	24.5	
3/8"	9.5	20	60	64	6,635	10.9	5.6	1,740,513	2,855	16.3	55.3	29.8	

US Customary Units													
Plate Thickness		Dimensions			Theoretical Area		Effective Area	Moment of Inertia		Radius of Gyration	Weight		
Gage	Decimal	X	Y	Side Flange	[in ²]	[in ² /in]	[in ² /ft]	[in ⁴]	[in ⁴ /in]	[in]	Full Plate	Half Plate	
	[in]	[in]	[in]	[in]							[lb]	[lb]	
12	0.10	0.58	2.04	2.00	2.94	0.12	0.73	0.78	0.03	0.52	34.5	18.7	
10	0.13	0.60	2.03	2.00	3.75	0.16	0.94	0.99	0.04	0.51	44.2	23.6	
8	0.16	0.63	2.12	2.13	4.60	0.19	1.15	1.37	0.06	0.55	52.8	28.4	
7	0.18	0.64	2.12	2.13	5.00	0.21	1.25	1.48	0.06	0.54	56.9	30.7	
5	0.21	0.67	2.21	2.25	5.85	0.24	1.46	1.95	0.08	0.58	68.5	37.0	
3	0.24	0.68	2.20	2.25	6.64	0.28	1.66	2.19	0.09	0.58	80.2	43.2	
5/16"	0.31	0.73	2.27	2.38	8.61	0.36	2.15	3.16	0.13	0.61	101.6	54.0	
3/8"	0.38	0.78	2.35	2.50	10.28	0.43	2.57	4.18	0.17	0.64	121.9	65.8	

Liner Plates

Specifications

Permissible Safe Loads on Circular Tunnels of Various Diameters or Arches for 24" Wide Smooth Liner Plates ¹⁾

SI Units									US Customary Units								
Safe Load Table (Loads in [kN/m ²])									Safe Load Table (Loads in [psf])								
Thickness [mm]	12 gage	10 gage	8 gage	7 gage	5 gage	3 gage	5/16"	3/8"	Thickness [in]	12 gage	10 gage	8 gage	7 gage	5 gage	3 gage	5/16"	3/8"
Diameter [m]	2.66	3.42	4.18	4.55	5.31	6.07	7.94	9.53	Diameter [ft]	0.1046	0.1345	0.1644	0.1793	0.2092	0.2391	0.3125	0.375
1.2 ²⁾	208	310	380	414	485	552	720	864	4 ²⁾	4,335	6,465	7,940	8,640	10,130	11,525	15,040	18,050
1.5	166	248	304	331	388	441	576	691	5	3,465	5,170	6,350	6,910	8,100	9,220	12,030	14,440
1.8		205	253	276	323	368	480	576	6		4,290	5,290	5,760	6,750	7,685	10,025	12,030
2.1			197	214	272	309	412	494	7			4,110	4,470	5,675	6,460	8,595	10,315
2.4				150	199	227	325	420	8				3,130	4,160	4,735	6,785	8,745
2.7					141	161	238	319	9					2,950	3,355	4,970	6,640
3.0						117	173	236	10						2,445	3,620	4,895
3.4							130	177	11							2,720	3,680
3.7							100	136	12							2,095	2,835
4.0								107	13								2,230
4.3								86	14								1,785
4.6									15								
4.9									16								
5.2									17								
5.5									18								
5.8									19								
6.1									20								

1) Note: 4-flange liner plates for tunnel diameters other than those shown in the tables are available. Please refer to DSI Underground engineering staff for a safe load determination outline

2) Not recommended for circular tunnel applications

Sectional Properties for 24" Wide Smooth Liner Plates

SI Units													
Plate Thickness		Dimensions			Theoretical Area		Effective Area	Moment of Inertia		Radius of Gyration	Weight		
Gage	Decimal	X	Y	Side Flange	[mm ²]	[mm ² /mm]	[mm ² /mm]	[mm ⁴]	[mm ⁴ /mm]	[mm]	Full Plate	Half Plate	
	[mm]	[mm]	[mm]	[mm]							[kg]	[kg]	
12	2.7	5	46	51	1,861	3.1	1.6	192,715	316	10.2	15.6	8.5	
10	3.4	5	45	51	2,383	3.9	2.0	243,079	398	10.2	20.0	10.7	
8	4.2	6	48	54	2,926	4.8	2.5	349,634	574	10.9	23.9	12.9	
7	4.6	6	48	54	3,185	5.2	2.7	377,938	619	10.9	25.8	13.9	
5	5.3	7	50	57	3,734	6.1	3.1	514,462	844	11.7	31.1	16.8	
3	6.1	7	50	57	4,249	7.0	3.6	578,562	949	11.7	36.4	19.6	
5/16"	7.9	8	52	60	5,545	9.1	4.7	857,853	1,408	12.4	46.1	24.5	
3/8"	9.5	10	54	64	6,654	10.9	5.6	1,168,362	1,917	13.2	55.3	29.8	

US Customary Units													
Plate Thickness		Dimensions			Theoretical Area		Effective Area	Moment of Inertia		Radius of Gyration	Weight		
Gage	Decimal	X	Y	Side Flange	[in ²]	[in ² /in]	[in ² /ft]	[in ⁴]	[in ⁴ /in]	[in]	Full Plate	Half Plate	
	[in]	[in]	[in]	[in]							[lb]	[lb]	
12	0.10	0.19	1.81	2.00	2.89	0.12	0.72	0.46	0.02	0.40	34.5	18.7	
10	0.13	0.20	1.77	2.00	3.69	0.15	0.92	0.58	0.02	0.40	44.2	23.6	
8	0.16	0.23	1.89	2.13	4.54	0.19	1.13	0.84	0.04	0.43	52.8	28.4	
7	0.18	0.24	1.89	2.13	4.94	0.21	1.23	0.91	0.04	0.43	56.9	30.7	
5	0.21	0.27	1.98	2.25	5.79	0.24	1.45	1.24	0.05	0.46	68.5	37.0	
3	0.24	0.28	1.97	2.25	6.59	0.27	1.65	1.39	0.06	0.46	80.2	43.2	
5/16"	0.31	0.33	2.04	2.38	8.59	0.36	2.15	2.06	0.09	0.49	101.6	54.0	
3/8"	0.38	0.38	2.12	2.50	10.31	0.43	2.58	2.81	0.12	0.52	121.9	65.8	

Liner Plates

Specifications

Allowable Jacking Loads on Circular Tunnels of Various Diameters for 16" Wide Smooth Liner Plates ¹⁾

SI Units						
Allowable Load [kN]						
Thickness [mm]	8 gage 4.18	7 gage 4.55	5 gage 5.31	3 gage 6.07	5/16" 7.94	3/8" 9.53
Diameter [m]						
1.2	445	525	738	970	1,708	2,651
1.5	560	658	916	1,210	2,135	3,309
1.8	676	792	1,103	1,450	2,562	3,977
2.1	783	925	1,290	1,690	2,989	4,635
2.4	898	1,059	1,468	1,930	3,416	5,302
2.7	1,014	1,192	1,655	2,180	3,843	5,960
3.0	-	-	1,841	2,420	4,270	6,628
3.4	-	-	2,019	2,660	4,697	7,286
3.7	-	-	-	2,900	5,124	7,953
4.0	-	-	-	-	5,551	8,611
4.3	-	-	-	-	5,978	9,279
4.6	-	-	-	-	-	9,937
4.9	-	-	-	-	-	10,604
5.2	-	-	-	-	-	11,262

US Customary Units						
Allowable Load in Short Tons (2000 [lbs])						
Thickness [in]	8 gage 0.1644	7 gage 0.1793	5 gage 0.2092	3 gage 0.2391	5/16" 0.3125	3/8" 0.375
Diameter [ft]						
4	50	59	83	109	192	298
5	63	74	103	136	240	372
6	76	89	124	163	288	447
7	88	104	145	190	336	521
8	101	119	165	217	384	596
9	114	134	186	245	432	670
10	-	-	207	272	480	745
11	-	-	227	299	528	819
12	-	-	-	326	576	894
13	-	-	-	-	624	968
14	-	-	-	-	672	1,043
15	-	-	-	-	-	1,117
16	-	-	-	-	-	1,192
17	-	-	-	-	-	1,266

Allowable Jacking Loads on Circular Tunnels of Various Diameters for 24" Wide Smooth Liner Plates ¹⁾

SI Units						
Allowable Load [kN]						
Thickness [mm]	8 gage 4.18	7 gage 4.55	5 gage 5.31	3 gage 6.07	5/16" 7.94	3/8" 9.53
Diameter [m]						
1.2	356	418	560	712	1,165	1,744
1.5	454	516	703	890	1,459	2,180
1.8	543	623	845	1,068	1,753	2,615
2.1	632	729	979	1,245	2,037	3,042
2.4	721	827	1,121	1,423	2,331	3,478
2.7	-	-	1,263	1,601	2,624	3,914
3.0	-	-	-	1,779	2,918	4,350
3.4	-	-	-	-	3,203	4,786
3.7	-	-	-	-	3,496	5,222
4.0	-	-	-	-	-	5,658
4.3	-	-	-	-	-	6,094
4.6	-	-	-	-	-	-
4.9	-	-	-	-	-	-
5.2	-	-	-	-	-	-

US Customary Units						
Allowable Load in Short Tons (2000 [lbs])						
Thickness [in]	8 gage 0.1644	7 gage 0.1793	5 gage 0.2092	3 gage 0.2391	5/16" 0.3125	3/8" 0.375
Diameter [ft]						
4	40	47	63	80	131	196
5	51	58	79	100	164	245
6	61	70	95	120	197	294
7	71	82	110	140	229	342
8	81	93	126	160	262	391
9	-	-	142	180	295	440
10	-	-	-	200	328	489
11	-	-	-	-	360	538
12	-	-	-	-	393	587
13	-	-	-	-	-	636
14	-	-	-	-	-	685
15	-	-	-	-	-	-
16	-	-	-	-	-	-
17	-	-	-	-	-	-

1) Note: 4-flange liner plates for tunnel diameters other than those shown in the tables are available. Please refer to DSI Underground engineering staff for a safe load determination outline



Liner Plates

Advantages of 4-Flange Tunneling Liner Plates over conventional 2-Flange Liner Plates

- All 4-flange liner plates are similar in size and shape, e.g. 2-flange plates vary considerably in length
- 4-flange liner plates are erected from inside the tunnel, whereas 2-flange plates require reaching behind the plates to install bolts and nuts
- 4-flange liner plates are the only liner plate system form which can be used to push off the liner plate flange with a TBM, MTBM, or shield without supplemental structural reinforcement
- Storage, manipulation, and erection of 4-flange liner plates requires less time and manpower
- Less excavation because 4-flange plates are only 50 to 65 [mm] (2 to 2 ½ [in]) deep while the deeply corrugated two-flange plates can be 100 to 125 [mm] (4 to 5 [in]) deep
- Less grout is used behind 4-flange plates because of the shallower corrugations versus the deeper 2-flange plates
- 4-flange liner plates are measured to the outside of plate while 2-flange plates are measured to the net neutral axis (NNA)

Liner Plate Support Types

- Liner plates only
- Ribs inside liner plates
- Liner plates between ribs

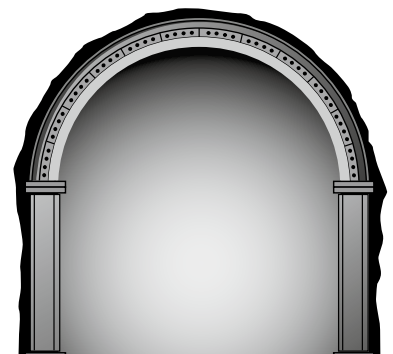
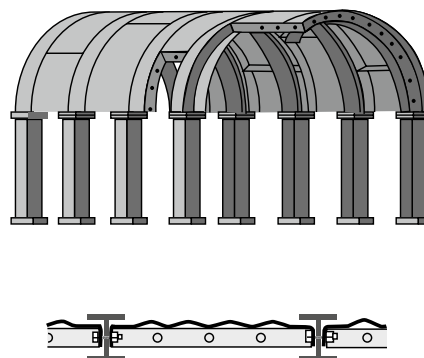
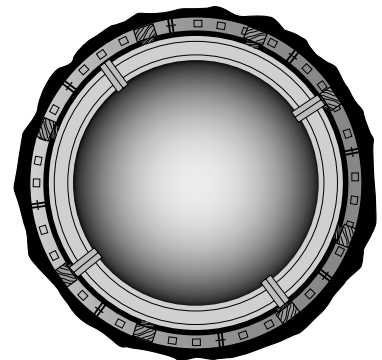
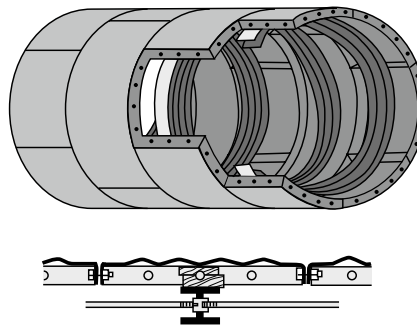
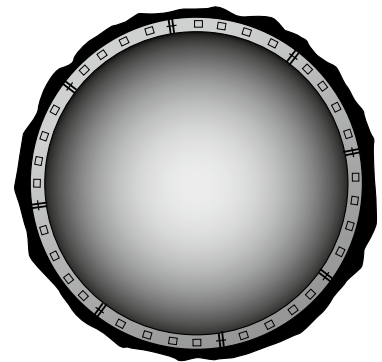
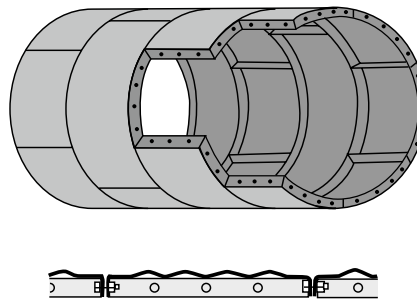

Liner Plates

Installation Procedure

Introduction

Tunnels excavated by full face, heading and bench, or multiple drift procedures are considered conventional methods. Liner plates used with any construction method utilizing a full or partial shield, a tunneling machine, or other equipment which will exert a force upon the liner plates to propel, steer, or stabilize the equipment are considered special cases and are not covered by these specifications. In any case, liner plates must be assembled in accordance with the manufacturer's instructions.

Assembly

4-flange liner plates and all accessories required for erection must be transported to the point of installation in advance. Preferably, the unsupported section (span) in the excavation area is always kept at a minimum, and complete liner plate rings are assembled at once. Full-face connection of 4-flange liner plates is accomplished using original bolts and nuts with quick acting coarse thread. The recommended procedure for bolt tightening is "turn of nut" per AISC (American Institute of Steel Construction).

Grouting

It is assumed that grouting is always performed to transfer ground loads to the 4-flange liner plates. Grout holes with plugs shall be provided at a spacing sufficient to allow filling of all voids with grouting material. Grouting or backfilling should start at the lowest grout hole and proceed upward, preferably filling both sides of the tunnel simultaneously. The frequency of grouting depends on ground conditions, tunnel diameter, and total length.



Further References

- AASHTO Standard Specification for Highway Bridges, Division I, Section 16
- AREMA Manual for Railway Engineering, Section 4
- Recommendations from DSI Underground for the determination of loading on tunnel liner plates

Liner Plates

Applications



PANTEX Lattice Girders

Introduction

PANTEX lattice girders have been developed for special demands in the field of Tunneling. The PANTEX system has been extensively tested and used successfully for numerous tunnel projects throughout the world.

PANTEX lattice girders ensure an immediate support in the open span area. Contrary to standard solid-web girders, PANTEX lattice girders are entirely integrated in the shotcrete lining; porous zones and shotcrete spray shadows are avoided.

The load-bearing capacity of PANTEX lattice girders has been investigated in terms of various loading tests and by numerical analysis. Flexibility regarding geometry and bearing capacity characterizes this passive support system for Underground applications.

Main Advantages

- Immediate support in the excavation area
- Partial static support action even without shotcrete embedding
- Utilization as a true-to-form template for shotcrete application
- Easy and quick assembly
- Simple handling and installation by a small crew
- Optimum bond and interconnection with the shotcrete lining
- Simple adjustment and shaping to the excavation geometry
- Ideal bearing for spiles and lagging boards
- Spiles may be installed both above or through the lattice girders
- No need for investment in major equipment



PANTEX Lattice Girders

System Description

- Load-bearing elements according to the particular demands in Tunneling
- Application in combination with shotcrete
- Spatial 3-bar or 4-bar girder construction, connected via stiffening elements (spiders)
- Reduction of girder buckling lengths by stiffeners
- 3-bar girder: single bar by default at the excavation side
- 4-bar girder: application as wallplate beam or stiff cross girder
- Caverns with side drifts: combined use of 3-bar and 4-bar bar girders
- Assembly of the full girder profile by connecting single girder elements
- Load transmission even before shotcrete application
- Integral part of the shotcrete lining reinforcement
- Proven bond according to the design principles of reinforced concrete



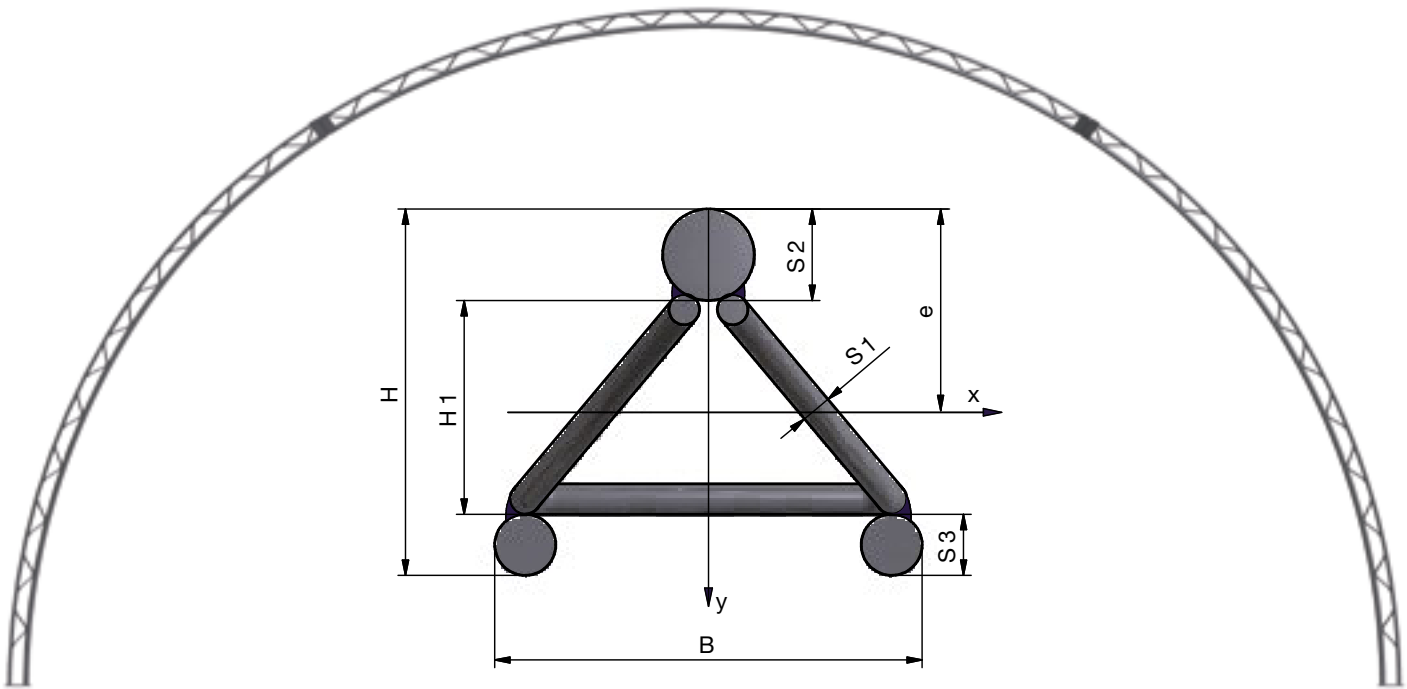

System Components ¹⁾

Region	Girder Bars	Stiffeners (Spiders)	Connections	Welding Process
North America	<ul style="list-style-type: none"> Smooth special grade reinforcing steel <ul style="list-style-type: none"> ASTM A572 grade 65 Yield strength ≥ 70 [ksi] (480 [MPa]) Tensile strength ≥ 80 [ksi] (550 [MPa]) Elongation $\geq 10\%$ 	<ul style="list-style-type: none"> ASTM A572 grade 70 	<ul style="list-style-type: none"> Plates: steel grade ASTM A36 or higher Connecting bolts: ASTM A325N or higher 	<ul style="list-style-type: none"> According to AWS requirements for gas metal arc welding (GMAW) Certified welders in accordance with AWS D1.1
Europe	<ul style="list-style-type: none"> Ribbed reinforcing steel <ul style="list-style-type: none"> B 500 B or higher (DIN 488-1 or OENORM B 4700) 	<ul style="list-style-type: none"> B 500 B (DIN 488-1 or OENORM B 4700) 	<ul style="list-style-type: none"> Plates: S235 (EN 10025-2) Connecting bolts: 8.8 (EN ISO 898-1) or higher 	<ul style="list-style-type: none"> DSI Underground factory specification

Allowable tightening torques and mounting pre-load for set metrical screws: see VDI guideline No. 2230, sheet 1

¹⁾ Lattice girder types with different rebar diameters and dimensions, hence equivalent design values (e.g. W_x), are possible

PANTEX Lattice Girders

Specifications 3-Bar Girders

SI Units										
Designation ¹⁾ [PS1-S3-S2]	Type (H ₁)	S1 [mm]	S2 [mm]	S3 [mm]	Weight ²⁾ [kg/m]	H [mm]	B [mm]	A [cm ²]	W _x ³⁾ [cm ³]	I _x [mm ⁴]
P50-20-25	50	10	25	20	10.2	95	100	11.19	28	148
P50-20-30		10	30	20	11.9	100		13.35	38	193
P50-20-36		10	36	20	14.3	106		16.46	42	246
P50-25-30		10	30	25	14.7	105		16.89	42	255
P50-25-36		10	36	25	17.1	111		20.00	58	336
P50-30-36		10	36	30	20.5	116		24.32	64	424
P70-20-25	70	10	25	20	10.4	115	140	11.19	37	239
P70-20-30		10	30	20	12.1	120		13.35	51	306
P70-20-36		10	36	20	14.5	126		16.46	54	383
P70-25-30		10	30	25	14.9	125		16.89	56	398
P70-25-36		10	36	25	17.3	131		20.00	77	517
P70-30-36		10	36	30	20.7	136		24.32	83	644
P95-20-25	95	10	25	20	10.8	140	180	11.19	49	384
P95-20-30		10	30	20	12.5	145		13.35	66	485
P95-20-36		10	36	20	14.9	151		16.46	69	598
P95-25-30		10	30	25	15.3	150		16.89	72	625
P95-25-36		10	36	25	17.7	156		20.00	100	799
P95-30-36		10	36	30	21.1	161		24.32	107	986
P115-20-25	115	12	25	20	11.0	160	220	11.19	58	525
P115-20-30		12	30	20	12.7	165		13.35	78	658
P115-20-36		12	36	20	15.1	171		16.46	82	804
P115-25-30		12	30	25	15.5	170		16.89	86	842
P115-25-36		12	36	25	17.9	176		20.00	120	1,070
P115-30-36		12	36	30	21.3	181		24.32	126	1,312
P130-20-25	130	12	25	20	11.2	175	220	11.19	66	644
P130-20-30		12	30	20	12.9	180		13.35	87	805
P130-20-36		12	36	20	15.3	186		16.46	91	980
P130-25-30		12	30	25	15.7	185		16.89	96	1,027
P130-25-36		12	36	25	18.1	191		20.00	134	1,299
P130-30-36		12	36	30	21.5	196		24.32	141	1,589

US Customary Units												
CP Size H ₁ ¹⁾		Bar Size			Weight ²⁾ [lb/ft]	H [in]	B [in]	e [in]	I _x [in ⁴]	S _x ³⁾ [in ³]	I _y [in ⁴]	S _y ³⁾ [in ³]
[mm]	[in]	S3 [#]	S2 [#]	S1 [in]								
50	1.97	6	8	0.39	6.72	3.70	3.94	2.01	3.441	1.716	2.324	1.180
		6	10		8.26	3.94		1.88	4.676	2.226	2.395	1.216
70	2.75	6	8	0.39	6.95	4.50	5.50	2.42	5.544	2.295	5.064	1.846
		6	10		8.59	4.77		2.20	7.375	2.886	5.135	1.867
		8	11		11.93	5.16		2.69	12.108	4.465	8.226	2.991
95	3.75	6	8	0.39	7.07	5.50	7.09	2.94	8.937	3.036	8.950	2.526
		6	10		8.70	5.77		2.59	11.741	3.751	9.028	2.548
		8	11		12.05	6.16		3.18	18.883	5.854	14.840	4.188
115	4.50	6	8	0.47	7.94	6.25	8.66	3.37	12.182	3.636	13.906	3.210
		6	10		9.58	6.52		2.91	15.849	4.416	13.985	3.229
		8	11		12.92	6.91		3.63	25.208	6.953	23.342	5.390
130	5.12	6	8	0.47	7.76	6.87	8.66	3.67	15.015	4.088	13.906	3.211
		6	10		9.39	7.14		3.15	19.379	4.929	13.977	3.229
		8	11		12.73	7.53		3.93	30.623	7.794	23.342	5.390

1) Designation: PH1-S3-S2, e.g. P130-20-30 or CPS1-S3-S2, e.g. CP130-6-8

2) Approximate weight including spiders (average values without joint and foot plates)

3) Quotient moment of inertia and maximum distance from the neutral axis to the outer fiber

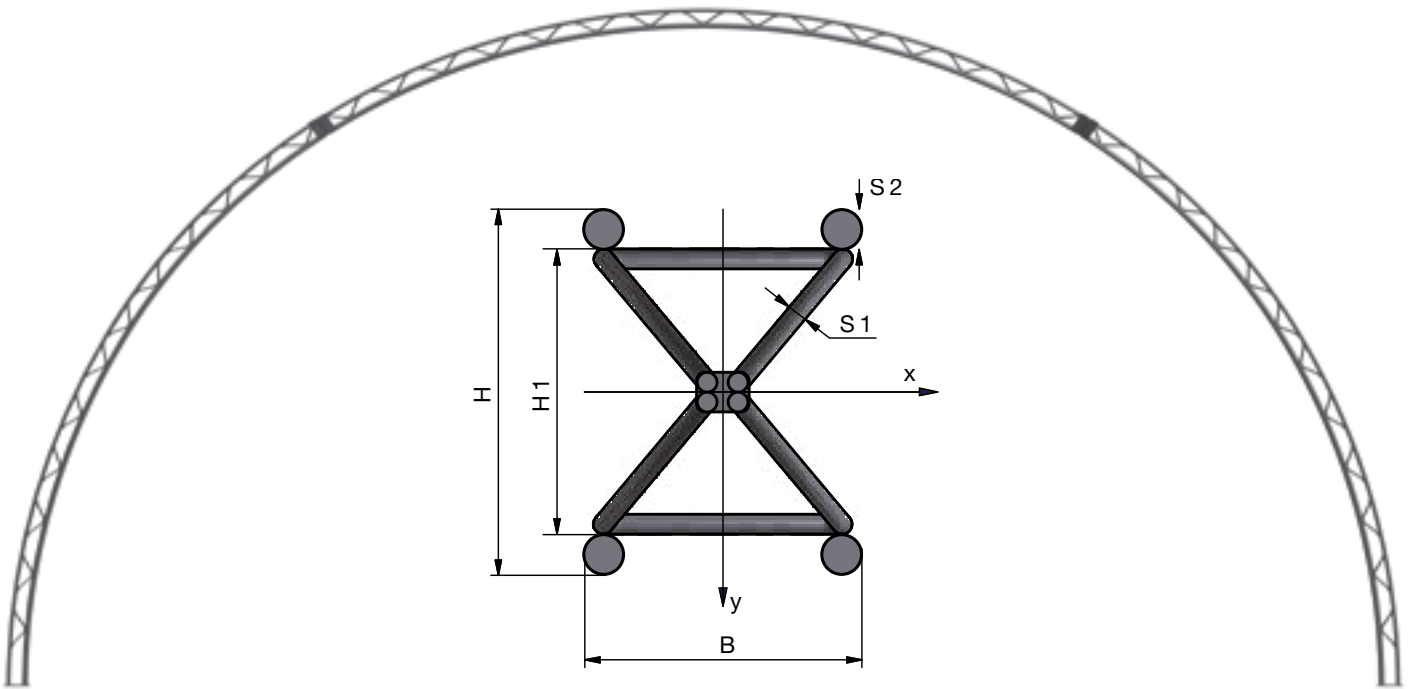

PANTEX Lattice Girders

Specifications 4-Bar Girders

SI Units									
Designation ¹⁾ [PS1-S2]	Type (H ₁)	S1 [mm]	S2 [mm]	Weight ²⁾ [kg/m]	H [mm]	B [mm]	A [cm ²]	W _x ³⁾ [cm ³]	W _y ³⁾ [cm ³]
P100-20	100	10	20	12.6	140	100	12.57	65	41
P100-25		10	25	18.2	150		19.63	103	57
P100-30		10	30	25.0	160		28.27	151	72
P100-36		10	36	34.8	172		40.72	223	90
P140-20	140	10	20	13.1	180	140	12.57	90	65
P140-25		10	25	18.7	190		19.63	141	94
P140-30		10	30	25.5	200		28.27	206	124
P140-36		10	36	35.2	212		40.72	301	162
P190-20	190	10	20	13.8	230	180	12.57	121	90
P190-25		10	25	19.4	240		19.63	190	132
P190-30		10	30	26.2	250		28.27	275	178
P190-36		10	36	36.0	262		40.72	399	238
P230-20	230	12	20	14.4	270	220	12.57	146	115
P230-25		12	25	19.9	280		19.63	229	170
P230-30		12	30	26.7	290		28.27	331	233
P230-36		12	36	36.5	302		40.72	479	316
P260-20	260	12	20	14.7	300	220	12.57	164	115
P260-25		12	25	20.2	310		19.63	258	170
P260-30		12	30	27.0	320		28.27	373	233
P260-36		12	36	36.8	332		40.72	539	316

US Customary Units											
CP Size H ₁ ¹⁾		S1	Bar Size S2	Weight ²⁾	H	B	A Bars	I _x	S _x ³⁾	I _y	S _y ³⁾
[mm]	[in]	[mm]	[#]	[lb/ft]	[in]	[in]	[in ²]	[in ⁴]	[in ³]	[in ⁴]	[in ³]
100	3.94	10	5	7.61	5.19	3.94	1.2	6.42	2.47	3.40	1.72
			6	8.88	5.44		1.8	9.77	3.59	4.55	2.31
			7	10.23	5.69		2.4	14.04	4.94	5.75	2.92
			8	13.43	5.94		3.1	19.34	6.52	6.97	3.54
			10	17.16	6.44		4.9	33.50	10.41	9.34	4.75
140	5.51	10	5	7.88	6.76	5.51	1.2	11.54	3.42	7.32	2.66
			6	9.14	7.01		1.8	17.32	4.95	10.03	3.65
			7	10.51	7.26		2.4	24.55	6.77	12.98	4.72
			8	13.71	7.51		3.1	33.38	8.90	16.10	5.86
			10	17.42	8.01		4.9	56.39	14.10	22.65	8.24
180	7.09	10	5	8.51	8.34	7.09	1.2	20.28	4.64	12.85	3.63
			6	9.78	8.59		1.8	30.13	6.70	17.82	5.03
			7	11.15	8.84		2.4	42.29	9.14	23.34	6.58
			8	14.35	9.09		3.1	56.94	11.99	29.32	8.27
			10	18.06	9.59		4.9	94.44	18.89	42.33	11.94
220	8.66	12	5	9.80	9.91	8.66	1.2	28.45	5.55	19.84	4.58
			6	11.06	10.16		1.8	42.06	8.01	27.71	6.40
			7	12.43	10.41		2.4	58.75	10.93	36.57	8.44
			8	15.63	10.66		3.1	78.74	14.32	46.29	10.65
			10	19.34	11.16		4.9	129.41	22.51	67.88	15.68

1) Designation: PH1-S2, e.g. P140-30 or CPH1-S2, e.g. CPH100-8

2) Approximate weight including spiders (average values without joint and foot plates)

3) Quotient moment of inertia and maximum distance from the neutral axis to the outer fiber

PANTEX Lattice Girders

Joint and Foot Plates

3-Bar Girders (SI Units)

Type Designation	Angle Connections			Foot Plates		
	Angle Steel (W x L x t) ¹⁾	Cut Length	G ²⁾	Size (W x L x t)	G	
[PH1]	[mm]	[mm]	[kg]	[mm]	[kg]	
P50	80 x 120 x 10	110	1.7	100 x 100 x 10	0.8	
			1.7			
P70		138	2.1		140 x 140 x 10	1.6
			2.1			
P95		165	2.5		145 x 180 x 10	2.1
			2.5			
			3.0			
P115		200	3.0		165 x 220 x 10	2.9
			3.0			
			3.2			
P130		210	3.2		180 x 220 x 10	3.2
			3.2			

1) Cut with 60° miter, weight: 15 [kg/m]

2) Weight per single angle – angle connections consist of 4 angle plates

Wallplate Beams

- 4-bar girders can be used as wallplate beams for crown drives
- Installation of 90° axial rotated 4-bar girders in the longitudinal direction
- Wallplate beams serve as bearing and profile template for installation of the girder arch
- Bend-proof frontal connection allows free crown advancing
- At the same time, wallplate beams are considered as statically effective reinforcement for the foot beam



PANTEX Lattice Girders





Joint and Foot Plates

3-Bar and 4-Bar Girders (US Customary Units)

CP Size [mm]	Joint Plate			Foot Plate		CP Size [mm]	Joint Plate			Foot Plate	
	Size [in]	Length [in]	Unit Weight [lb]	Size [in]	Unit Weight [lb]		Size [in]	Length [in]	Unit Weight [lb]	Size [in]	Unit Weight [lb]
50	L4x3x3/8	4 9/16	3.2	3/8x5x5	2.7	100	5 1/4	5.6	1/2x5x7	5.0	
		4 9/16	3.2				5 1/2	5.9			
		5 5/16	3.5				5 3/4	6.1			
70		5 1/2	3.7	3/8x6x6	3.8		6	6.4			
		5 3/4	3.9				6 1/2	6.9			
		6 9/16	4.4				6 3/4	7.2			
95	L5x3x1/2	6 3/4	4.6	3/8x7x8	6.0	140	7	7.5	1/2x7x9	8.3	
		7 1/16	4.8				7 1/4	7.7			
		7 11/16	8.0				7 1/2	8.0			
115		7 13/16	8.1	3/8x8x9 1/2	8.1		8	8.5			
		8 1/8	8.4				8 3/8	8.9			
		8 1/8	8.4				8 5/8	9.2			
130	L5x3x1/2	8 5/16	8.6	3/8x8x9 1/2	8.1	180	8 7/8	9.5	1/2x8x10 1/2	11.9	
		8 3/4	9.3				9 1/8	9.7			
							9 5/8	10.3			
				9 15/16	10.6						
				10 3/16	10.9						
			10 7/8	11.1	5/8x10x12		21.2				
220	10 11/16	11.8	11 3/16	11.9							

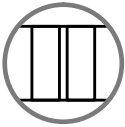

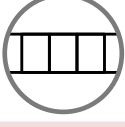
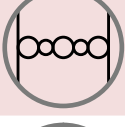
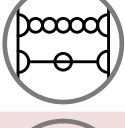
System Solutions

	Hard Rock Mining	Coal Mining	Mine Rehabilitation	Tunnel Rehabilitation	TBM's and Foundations ¹⁾
Support Pillars 	Auxiliary standing support, artificial pillars, and cornerslumps	Secondary support in room & pillar and longwall mining	Repair works in overstressed or fault zone areas and rehabilitation of visitor mines		
Roof Support Backfilling 	Backfilling of steel support for permanent main roadways	Yielding support system – displacement minimization	Re-establishment of the load-bearing capacity and yielding ability of destructed tunnel linings	Foundation and prestressing of pipe umbrella support or rib support systems	Temporary steel frame support for the construction of cross-cuts
Roadway Packs and Dams 		Multiple entry roadways, gaseous seams, and deep mining operations			
Structural Bulkheads 	Sealing against backfilling media	Permanent sealing of roadways	Partition of storage or waste facilities		
Stoppings 	Ventilation walls, sealings, and face shuttering				
Structural Sealings 				Sealing of existing re-lined tunnels and annular gaps of civil structures	O-ring sealings: launch and receptions of TBM's, sealing against water (liquids) and compressed air

1) See separate section BULLFLEX® structural sealings

Introduction

The BULLFLEX® system has been developed as a special supporting member for Underground excavation. It consists of patented textile groutable hoses made of high-strength fabric, which are subsequently filled with cement-bonded construction material, featuring an excellent load-bearing capacity.

The BULLFLEX® system is available in different dimensions, allowing an optimum alignment to the excavation or support perimeter. All system components are light-weight and easy to transport and to install.

DSI Underground has long-time experience in the application of the BULLFLEX® system which has been successfully used in various projects.

Main Advantages

- Fast, safe, and clean support system
- High load-bearing capacity
- Immediate load transfer and defined grout consumption
- Active setting load and controlled residual load
- Shrink-free
- Quick and easy to install
- Easy handling on-site due to light-weight components
- Application possible even in limited space
- Inflation can be achieved using various filling media
- Flexible support characteristics thanks to different variations of pillar diameter and filling media



BULLFLEX® Support System

System Description

The BULLFLEX® system is used wherever a fast support solution is required. Due to its active setting load and immediate load transfer, BULLFLEX® groutable hoses work like a strong hydraulic prop that can be left in position as a permanent support.

When using certain filling media, BULLFLEX® groutable hoses are shrink-free because of their patented encasement – woven fabric hoses made of high-strength fibers.

Depending on the required supporting load or geometry, the BULLFLEX® system can easily be adapted to on-site conditions using different diameters or filling media with varying compressive strengths.

Support Pillars: Coal



Support Pillars: Hard Rock



Roof Support Backfilling



Roadway Packs and Dams



Structural Bulkheads



Stoppings



BULLFLEX® Support System

System Description

Support Pillars

- Active pre-loading feature
- Increase of safety support factor or extraction rate

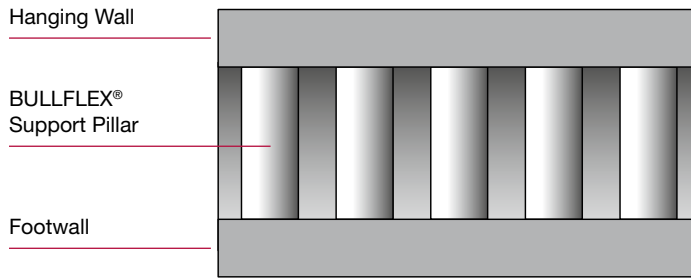

Roof Support Backfilling

- Full load distribution versus point loading
- Change from a passive to an active support system
- Full bedding of the steel profile leads to an enhanced utilization rate and may allow use of the next smaller profile type

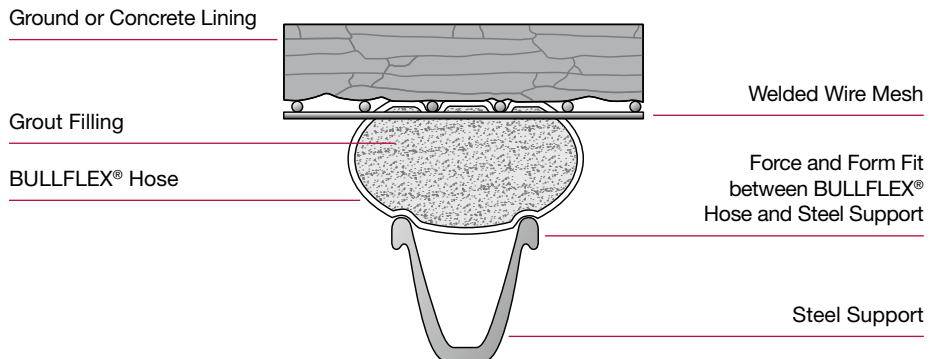

Roadway Packs and Dams

- Combined support and sealing system
- Flexible pillar height

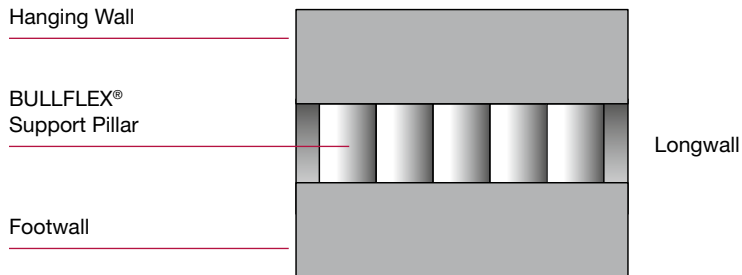

Structural Bulkheads

- Defined support system for backfilling applications
- Active vertical and horizontal prestressing

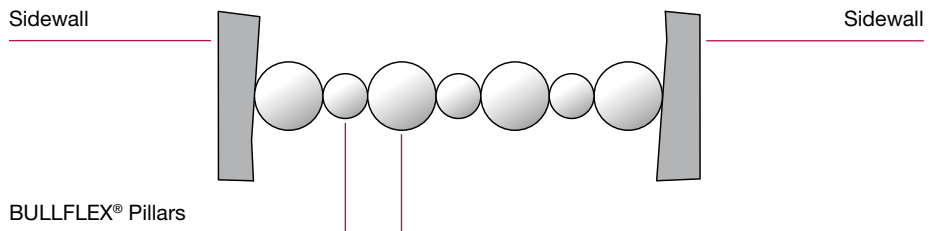

Stoppings

- Light and heavy duty versions
- Low weight and rapid installation

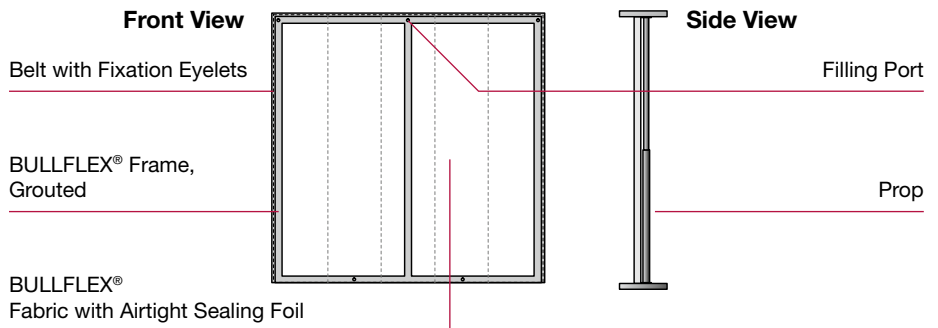

BULLFLEX® Support System

System Components

- BULLFLEX® groutable hoses
 - Endless round woven hoses made of polyamide 6.6
 - High resistance against tearing and no longitudinal seams
 - Anti-static, flame resistant, and self-extinguishing
 - Working pressure up to 4 [bar] (58 [psi])
 - Air and water permeable
 - Retention of the grout mineral content while draining due to the special filter effect of the BULLFLEX® system
 - Compliance with filter self rescuer systems
 - Off-size diameters and special designs are available on request
 - Patented product technology



Application	Diameter		Length / Height	
	[mm]	[in]	[m]	[ft]
Support pillars	280 - 960	11 - 38 ¹⁾	1.5 - 7.1	5 - 23
Roof support backfilling	230 - 400	9 - 16	Length as required	
Roadway packs and dams	480 - 960	19 - 38 ¹⁾	1.5 - 7.1	5 - 23
Structural bulkheads	280 - 960	11 - 38 ¹⁾	Length as required	
Stoppings	Flat fabric		Length as required	

1) Larger diameters available on request

- BULLFLEX® filling ports
 - Pre-manufactured with integrated upper closure, filling port(s), and bottom plate
 - With check valve, inner diameter 32 [mm] (1¼ [in]) or 50 [mm] (2 [in])
 - Number of filling ports depending on the length/height of the BULLFLEX® groutable hoses
- BULLFLEX® filling nozzle
- BULLFLEX® multiple-use formworks
 - For installation of larger-size BULLFLEX® groutable hoses, multiple-use steel formworks are required
 - Stabilization and fixation during installation (inflation)
- Filling material
 - See table for recommended injection material



BULLFLEX® Support System

System Components

Standard Dimensions ¹⁾

Designation [-]	Hose Diameter		Inflated Groutable Hose	
	[mm]	[in]	[mm]	[in]
9 - 11"	230	9	280	11
13 - 15"	320	13	380	15
16 - 19"	400	16	480	19
20 - 23"	500	20	590	23
25 - 29"	630	25	740	29
31 - 38"	800	31	960	38

1) Intermediate and larger diameters available on request



Specifications

Characteristics ¹⁾		Unit	Value	Remarks
Material		[-]	Polyamide 6.6	Nylon
Weight		[g/m ²] / [oz/yd ²]	Approx. 660 / 19.5	
Fabric thickness		[mm] / [in]	Approx. 1 / 0.04	
Minimum tensile strength	L ²⁾ T ³⁾	[N] / [lbf]	12,000 / 2,698 24,000 / 5,395	100 [mm] / 3.94 [in] width According to ISO 10319
Corresponding maximum elongation	L ²⁾ T ³⁾	[%]	20 20	According to ISO 10319
Elastic elongation	L ²⁾ T ³⁾	[%]	15 15	According to ISO 10319
Minimum seam strength		[kN/m] / [lbf/ft]	155 / 113	
Airflow through fabric at pressure [mbar] ([psi])	10 (0.15) 20 (0.30) 30 (0.45)	[L/min] / [gal/min]	6.5 / 1.7 13 / 3.4 19 / 5.0	At 100 [cm ²] / 15.5 [in ²]
Residual tensile strength		[%]	20 - 30	After 1 year and under light exposure in Florida

1) The indicated values are laboratory values and may deviate on-site

2) Longitudinal

3) Transversal



BULLFLEX® Support System

Installation Procedure Support Pillars

1. At the pillar position, gravel and boulders must be removed from the footwall. If possible, the footwall area should be horizontal or parallel to the incline of the hanging wall.
2. For support pillars ≥ 2.5 [m] (8.2 [ft]): subsequent mounting of the temporary or permanent formwork, which should reach up to a height of approx. 200 [mm] (8 [in]) below the hanging wall. Placement of the fabric into the formwork and fixation by loops attached to the fabric.
3. For support pillars < 2.5 [m] (8.2 [ft]): installation without formworks; the fabric is fixed to the hanging wall by loops, the bottom plate should be positioned approx. 50 [mm] (2 [in]) above the footwall.
4. Inflation of the BULLFLEX® pillar through one or several filling ports until full contact with the roof has been established.
5. Increase of the filling pressure up to 4 [bar] (58 [psi]) to achieve active pre-loading.
6. If a temporary formwork has been used, it may be removed as soon as the concrete filling has reached a curing strength of 5 [N/mm²] (725 [psi]) and then be re-used for setting the next pillar.

Note: during inflation (cement injection), all default and recommended personal protective equipment must be used. BULLFLEX® pillars are resistant against mine water inflow; the fabric itself is only soluble in concentrated inorganic acids and phenol.



Characteristics Support Pillars

Pillar Diameter ¹⁾		Max. Recommended Pillar Height ²⁾		Active Pre-Loading ³⁾		Injection Material Consumption ⁴⁾		Average Inflation Time ⁴⁾
[mm]	[in]	[m]	[ft]	[kN]	[kip]	[m ³]	[ft ³]	[sec]
480	19	3.6	12.0	100	22	0.2	7.0	85
590	23	4.4	14.5	150	34	0.3	10.5	125
740	29	5.2	17.0	240	54	0.4	14.0	200
960	38	7.1	23.5	400	90	0.7	24.5	330

1) Other dimensions available on request

2) At a slenderness ratio of 30, rounded

3) Calculated at a filling pressure of 4 [bar] (58 [psi]) and for two contact areas (hanging wall and footwall), rounded

4) Calculated for 1 [m] (3.3 [ft]) pillar height and at a flow rate of 130 [L/min] (34.5 [gal/min]), rounded



Load-Bearing Capacity Support Pillars

SI Units

Type [in]	Height [m] and Load-Bearing Capacity [kN]				
	0.9	1.2	1.5	1.8	2.1
16 - 19"	1,570	1,522	1,474	1,427	1,379
20 - 23"	2,412	2,353	2,295	2,236	2,178
25 - 29"	3,850	3,777	3,703	3,630	3,556
31 - 38"	6,564	6,469	6,374	6,279	6,183

Type [in]	Height [m] and Load-Bearing Capacity [kN]				
	2.4	2.7	3.0	3.4	3.7
16 - 19"	1,332	1,284	1,236	1,189	1,141
20 - 23"	2,119	2,061	2,002	1,943	1,885
25 - 29"	3,483	3,409	3,336	3,263	3,189
31 - 38"	6,088	5,993	5,898	5,802	5,707

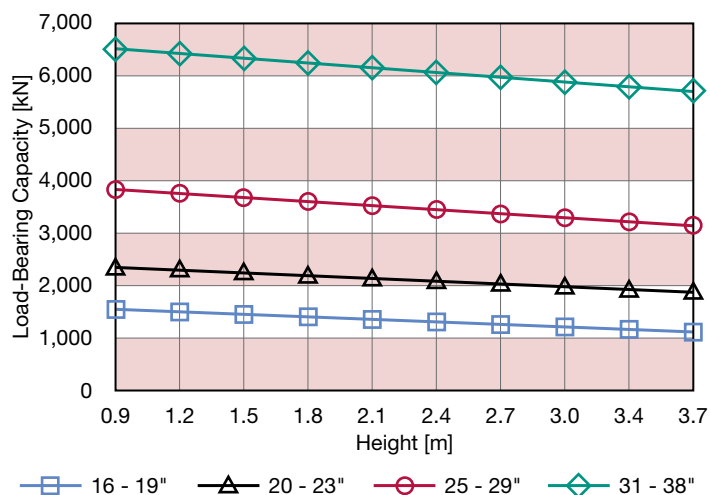

US Customary Units

Type [in]	Height [ft] and Load-Bearing Capacity [kip]				
	3	4	5	6	7
16 - 19"	353	342	331	321	310
20 - 23"	542	529	516	503	490
25 - 29"	866	849	833	816	799
31 - 38"	1,476	1,454	1,433	1,412	1,390

Type [in]	Height [ft] and Load-Bearing Capacity [kip]				
	8	9	10	11	12
16 - 19"	299	289	278	267	257
20 - 23"	476	463	450	437	424
25 - 29"	783	766	750	733	717
31 - 38"	1,369	1,347	1,326	1,304	1,283

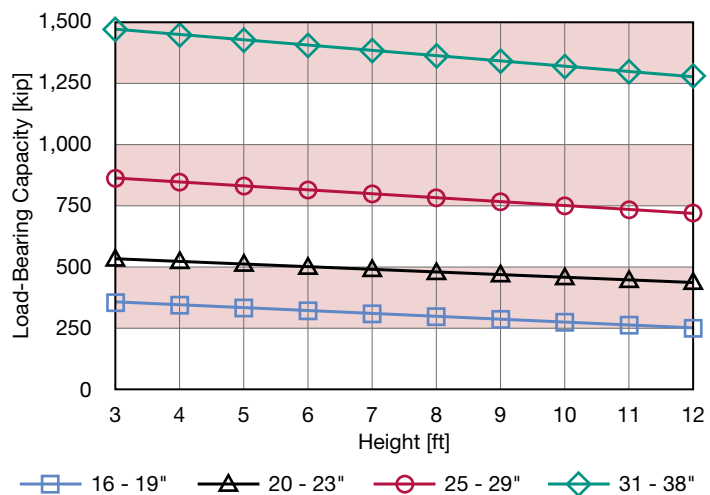

- Load-bearing capacity depending on pillar height, calculated
- Without consideration of active setting load
- Calculation basis for pre-dimensioning, including factors of safety
- Actual in-situ load-bearing capacity determined by static load tests, exceeding the stated values
- Examined in the course of a static load test series at the NIOSH ground control laboratories (Pittsburgh, PA, USA)
- Project-specific design proposals available on request



Further References

- Van Zanten, R. V.: Geotextiles and Geomembranes in Civil Engineering. A.A. Balkema. Rotterdam/Boston, 1986. ISBN 90 6191 6240. Page 156 ff.
- Safe application of mine roadway support systems. Rock Mechanics Technology Ltd, 2004. ISBN 0 7176 2847 7
- Breinig, F., Opolony, K.: Geplante Doppelnutzung einer Rechteckankerstrecke in 1200 m Teufe im Flöz D2/C. Martens, P.N. (ed): Aachen International Mining Symposia 2004. Glückauf, Essen, 2004. Page 159 ff.
- Declaration of conformity and material data sheets
- German approval for Underground application (No. 18.43.21-61-40)
- British COAL acceptance scheme (No. NMM 5318) for the use of the material (fabric) as Underground support element
- Nitschke, A.G. et al.: Innovative Rehabilitation of Existing Tunnels Under Minimum Impact on Operation. 2015 SME Annual Meeting, Preprint 15-131, February 2015

Two Concepts for Optimum Installation Performance

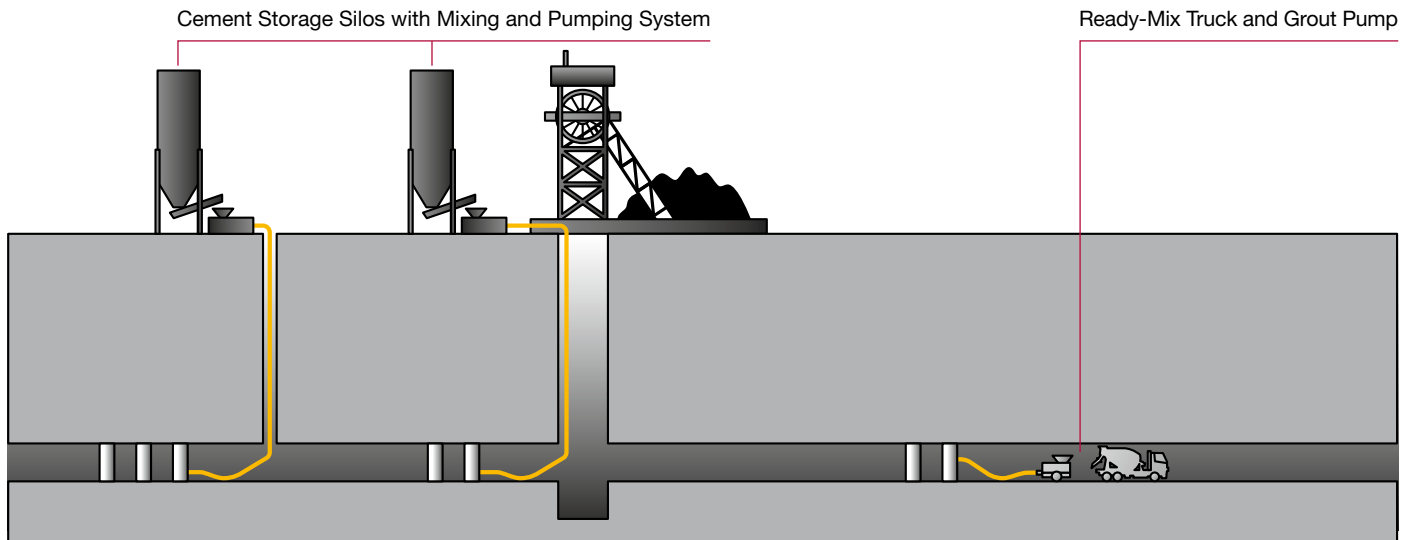

Recommended Injection Material ¹⁾

Characteristics	Unit	Value	Remarks
Composition	[%]	25 - 50% Portland cement 75 - 50% Fly ash	Alternatively, stone powder or a mixture of fly ash and sand can be used instead of fly ash ²⁾
Compressive strength after 1 day	[N/mm ²] / [psi]	> 2 / > 290	EN 196 / ASTM C1019
Compressive strength after 28 days	[N/mm ²] / [psi]	> 25 / > 3,630	EN 196 / ASTM C1019
Slump class	[-]	Medium-high	EN 12350-5 / ASTM C143
Max. grain size	[mm] / [in]	3.8 / 0.15	Default aggregate grading curve
W/C ratio	[1]	0.7 - 0.9	
Setting time	[min]	30 - 120	

1) Further references: ASTM C1107; ASTM C827; ASTM C143; EN 1045; EN 206-1

2) Aggregates may not have constituents harmful to concrete

Main Factors affecting the Workability of the Injection Medium

- Water-cement ratio
- Amount and type of aggregate and cement
- Ambient temperature
- Chemical admixtures

Requirements Pumping and Mixing Equipment

- Application of either a separate mixing and pumping unit, or a combined mixing/pumping device
- Pumpable with standard worm pumps for flooring or injections works with a nominal power of 7.5 to 12 [kW] and a minimum flow rate of 20 [L/min] (5 [gal/min])
- Default filling rates should be in the range of approx. 80 - 180 [L/min] (21 - 48 [gal/min])



Recommendations for Installation

- Ensure that injection hoses are laid out without kinks, avoid contact with any sharp edges in order to prevent the fabric from being damaged
- Wherever there is a change of direction, the bending radius must be greater than six times the outside hose diameter
- Screw pumps are high-pressure pumps, therefore only steel-reinforced hoses may be used for grout transport
- Before starting the machine, ensure that easily workable grout is being used
- The intake hose must not leak anywhere (especially not at connections), and the inner side of the hoses must be sufficiently lubricated

Introduction

Lining stress controllers (LSC™) have been developed as special supporting measure for highly squeezing ground conditions. The primary tunnel lining is divided into several segments by longitudinal construction joints. The purpose of this segmentation is the ability to absorb large deformations occurring during tunnel driving in weak ground.

LSC™ steel elements are installed into these deformation joints. The elements have a defined workload during compression so the primary lining is not damaged.

DSI Underground has long-time experience in the application of LSC™ elements, which have been successfully used for many projects.

Main Advantages

- Maintenance of supporting forces and optimum utilization of the load-bearing capacity of the primary lining
- Controlled stress release and deformability
- Steady increase of support resistance while undergoing large deformations
- Rapid increase of support resistance in slowly increasing deformations
- Avoidance of excessive tunnel liner overstressing
- Custom-specific adaptation of the deformation characteristics of LSC™ elements in accordance with project requirements
- The most effective lining stress controller currently used in Tunneling

System Description

Compared to the strength of the primary lining, the load-bearing resistance of LSC™ elements is dimensioned at a lower level. Thus, large deformations can be absorbed by LSC™ elements before the tunnel lining is damaged. The optimum supporting effect is created by selecting the best suited LSC™ elements and the proper number of compression bodies which determine the overall load-bearing resistance characteristics.

Single yielding elements are aligned between base plates. These plates fix the position of the yielding elements and limit LSC™ elements towards the tunnel lining. Each yielding element has a factory-set imperfection where controlled deformations start in case of excessive loading.



LSC™ Elements

System Components

- Base plates
- Yielding elements
- Holding bars

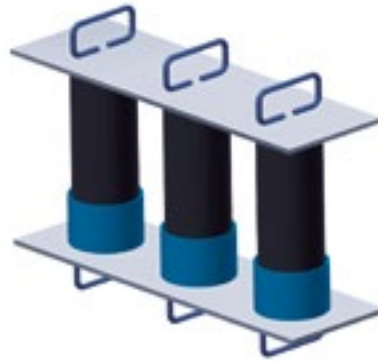

Specifications

Characteristics ¹⁾	Unit	Type	
Number of yielding elements	[-]	3	4
Length	[mm]	750 - 1,000	1,000 - 1,300
	[in]	29.5 - 39.4	39.4 - 51.2
Width	[mm]	250 - 350	
	[in]	9.8 - 13.8	
Height	[mm]	410	
	[in]	16.1	

1) Standard types for Tunneling. LSC™ elements with alternative dimensions available on request

Technical Characteristics

The type, quantity, and length of LSC™ elements is optimized to the load-bearing capacity of the primary lining and typical displacements measured at the tunnel wall

- Load-deformation characteristics can be changed to permit an adaption of the support resistance
- Project-specific customization of the LSC™ element geometry
- Load-deformation characteristics of the LSC™ system with three yielding elements (type 3) are defined with upper and lower limits as shown in the diagram

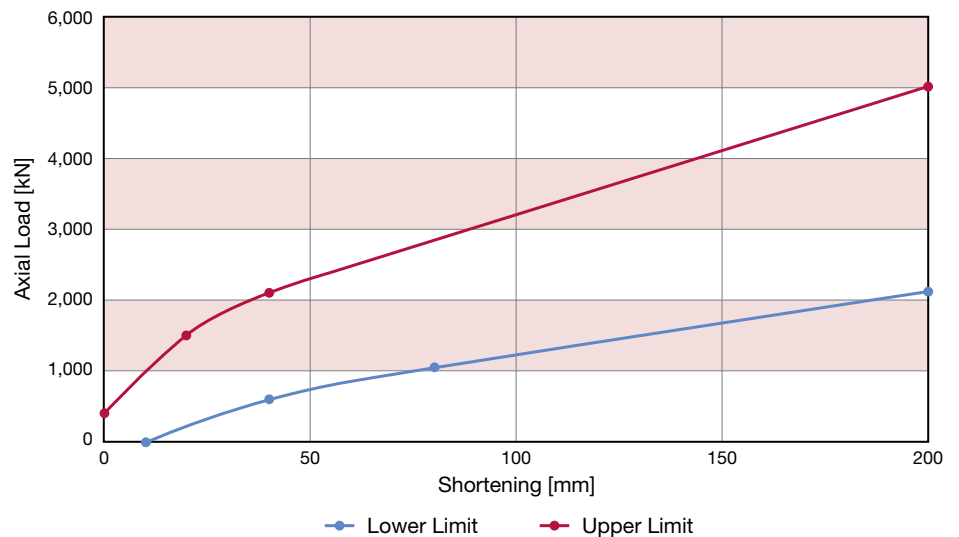





Rock Reinforcement

Fields of Application

Mechanical Anchors

GEWI® mechanical anchors and mechanical rebar anchors are well established systems with a free lengths. Anchors with a variable free length enable pre-tensioning and thus an active force transmission. The maximum load-bearing capacity of a mechanical anchor is mainly determined by the stability of the borehole (ground characteristics), the amount of pre-tensioning, and the design of the expansion shell.

- Systematic anchoring for Underground applications
- Doweling of layers in the hanging wall
- Utility hangers

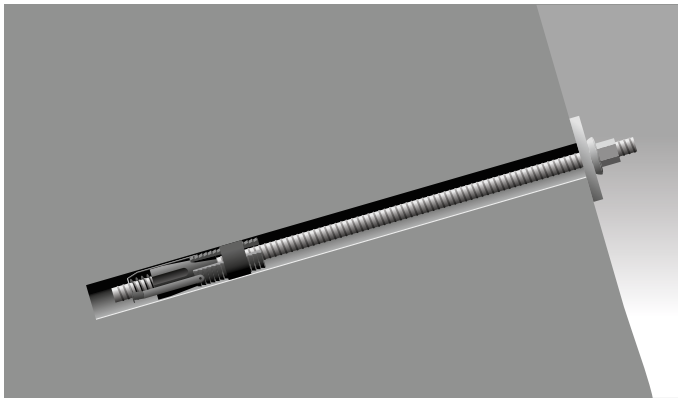

THREADBAR and Rebar Bolts (SN-Anchors)

Bolts increase the self-supporting ability of the ground and limit the loosening of blocks as well as shear displacements. Furthermore, the frictional force between individual ground layers is increased. Common bolt types, such as SN-Anchors or a THREADBAR, are fully grouted over the entire length and are usually installed un-tensioned. Cement or resin grouts are used as bonding media between borehole wall and tendon. Bolts can also be tensioned using an end-anchorage consisting of fast curing resin cartridges.

- Proven system for systematic bolting
- Application in combination with cement or resin grouts

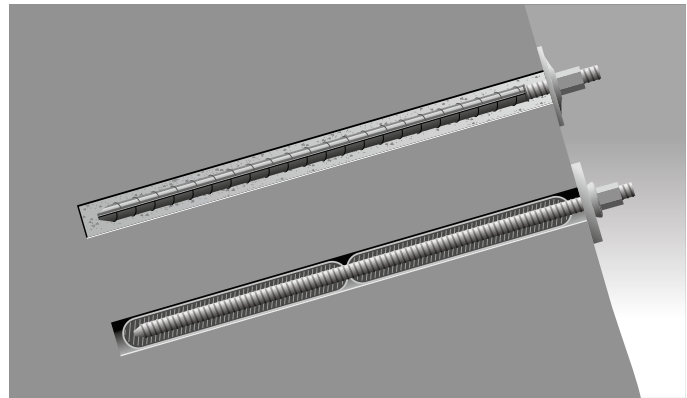

Combination Bolts

- Systematic permanent reinforcement for Underground applications
- Ground support for areas with limited or no access during operational lifetime
- Roadways and excavations with an extended lifetime
- Hydropower and Underground oil or gas storage caverns
- Sub-sea and sewer tunnels
- Rock fall protection

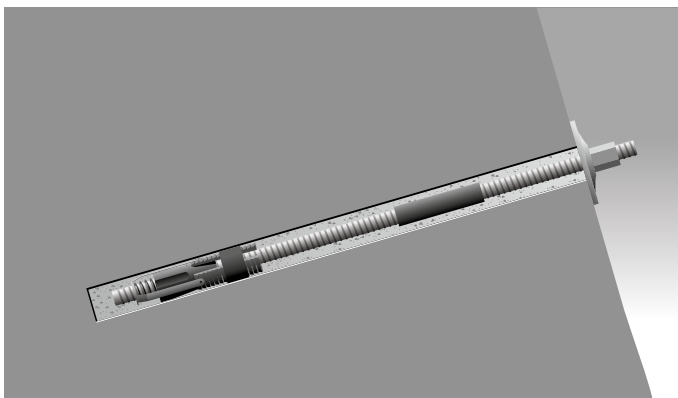

Resin Cartridges

- Two-component resin cartridges for Underground applications
- Default use in combination with rebar bolts
- Bolting operations where immediate load-bearing capacity is required
- Resin grouting for rehabilitation works
- Resin cartridges with different curing times available

Cement Cartridges

- Bonding of rebar bolts
- Anchorage of steel dowels in concrete structures
- Reinforced or soft cartridges for different applications available

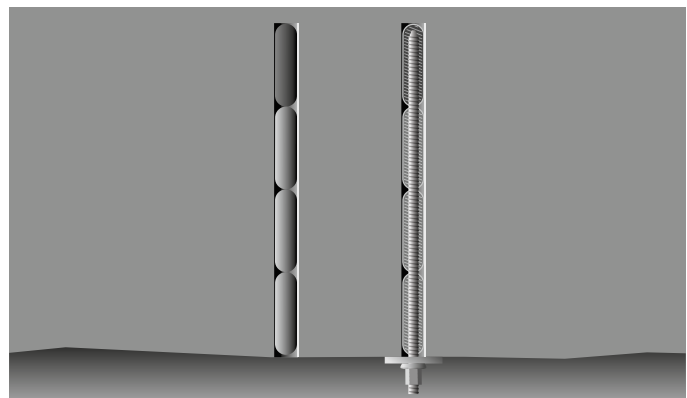

Rock Reinforcement

Fields of Application

Expandable Friction Bolts

- Systematic reinforcement in Underground excavations
- Fast and flexible bolting operations
- Generally used for temporary ground control purposes

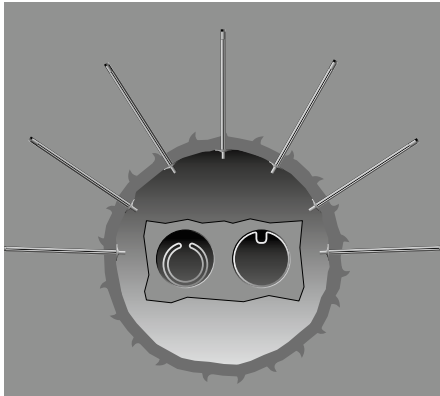

Friction Stabilizers

- Systematic reinforcement in Underground excavations
- Generally used for temporary ground control purposes
- Bolting in medium to hard ground
- Supplementary and utility bolting



Cable Bolts

- Bolting in limited space conditions
- High-strength ground control elements for critical sections
- Supplementary bolting
- Reinforcement of machine or utility caverns

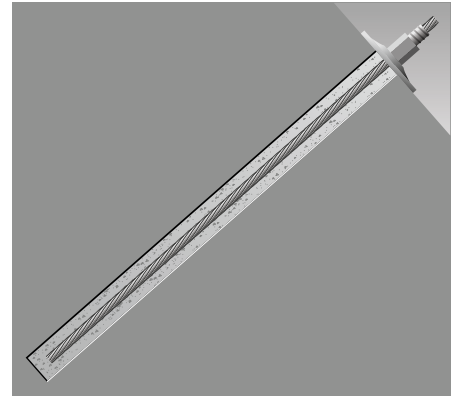

GRP Bolts

- Mechanical excavation – TBM's, roadheaders, and continuous miners
- Cutable bolt system - portals and temporary rock reinforcement to be removed by excavators
- Face support
- Ground stabilization in special foundations
- Injection lance for DYWI® Inject Systems

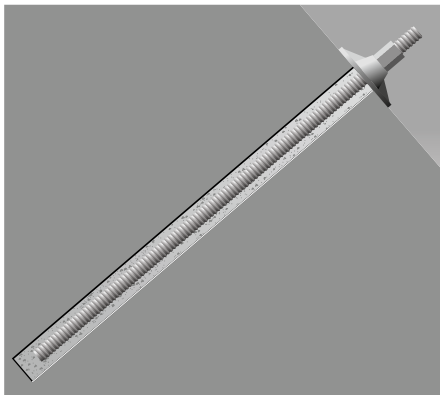

Accessories

- Plates
- Rock drilling equipment
- Mesh and straps

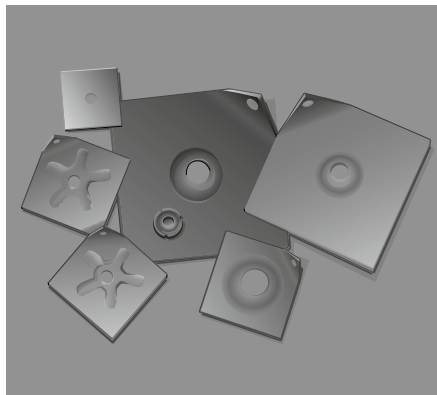

Pull Testing Equipment

- Pull-out tests
- Supervision and determination of quality criteria on installed bolts
- Research and development in the field of ground control technology



Rock Reinforcement

Self-Drilling Bolts

DYWI® Drill Hollow Bar System

- Radial bolting
- Stabilization of tunnel portals, trenches, and cut-and-cover areas
- Face stabilization
- Foot piles and rib bolting
- Injection works

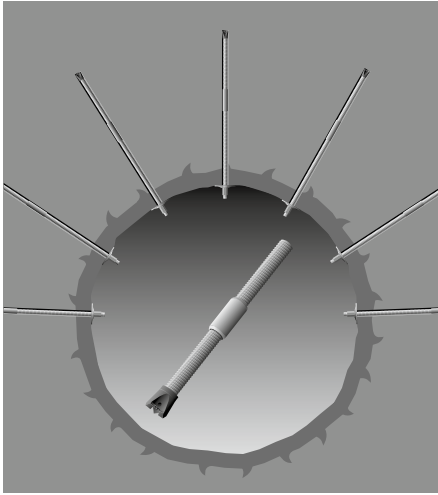

DYWI® Drill S-D Combination Bolt

- Bolting operations in remote areas or areas of difficult access
- Reinforcement of Underground caverns or highwalls
- Face bolts
- Squeezing ground



POWER SET S-D Friction Bolt

- Systematic self-drilling reinforcement
- Improved load-bearing capacity
- Bolting in areas which are prone to ground falls or difficult to access
- Bolting in medium to hard ground
- Unstable boreholes



S-D GRP Hollow Bars

- Self-drilling ground control
- Unstable boreholes
- Injection lance
- Face support
- Cuttable by roadheaders or TBM's



POWER SET Automation Unit

- Automated installation of the POWER SET S-D friction bolt
- Attachment unit for drill jumbos or continuous excavation machinery
- Bolting operations in areas difficult to access
- Magazine for six bolts per installation cycle
- Optional installation of an expansion element for increased load-bearing capacity

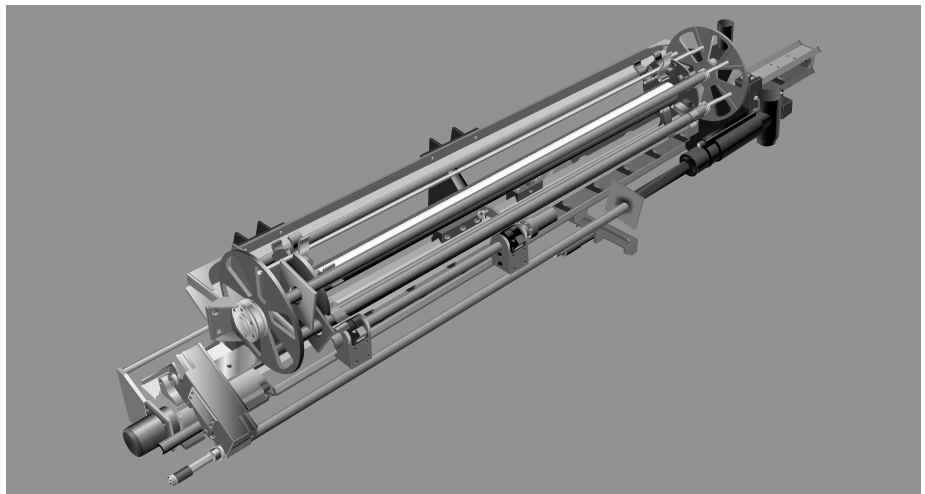

Contents

Mechanical Anchors	100
THREADBAR	102
Rebar Bolts (SN-Anchors)	104
DYWI® Drill Combination Bolts	108
CT-Bolt™ Combination Bolts	109
Resin Cartridges	112
Cement Cartridges	115
OMEGA-BOLT® Expandable Friction Bolts	116
POWER SET Self-Drilling Friction Bolts	120
POWER SET Automation Unit	123
Friction Stabilizers	126
Cable Bolts	128
Cable Bolt Tensioners	131
GRP Bolts	132
Accessories	136
Rock Drilling Equipment	138
Mesh and Straps.....	139
Pull Testing Equipment	140

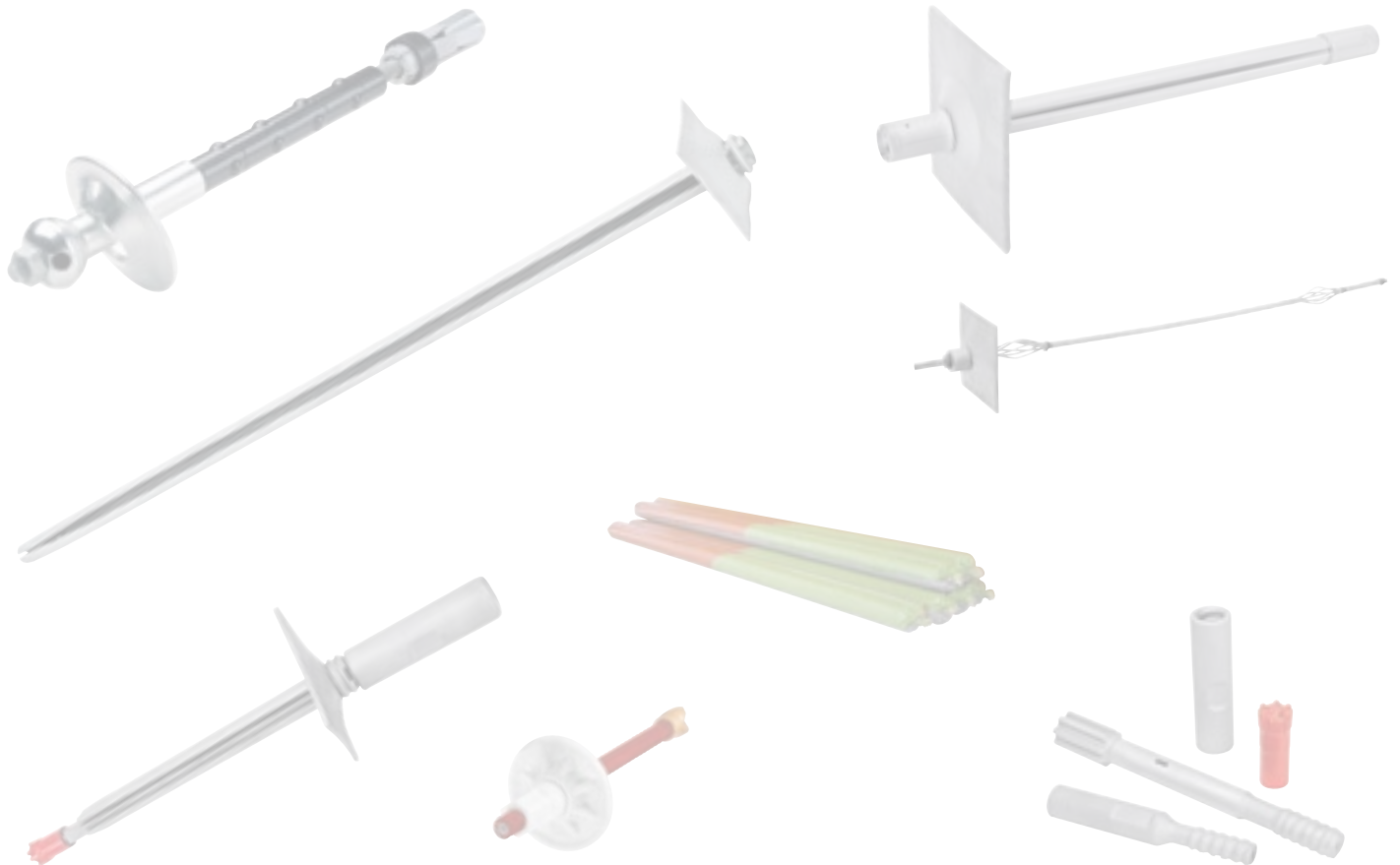

Mechanical Anchors

Main Advantages

- Simple handling and optimized installation time
- Immediate load-bearing capacity
- Field-proven and reliable anchors
- Unproblematic installation in aquiferous boreholes
- Optimized ratio of anchor force vs. borehole diameter

GEWI® Mechanical Anchor

- Continuous threaded GEWI® anchor bars allow flexible length adjustments and posterior extension on site
- Expansion sleeves are available for different borehole diameters
- German approval for Underground application

Mechanical Rebar Anchor

- Round or threaded rebar steel
- Forged or threaded head versions

System Components

- Steel expansion shell
 - Different versions available on request
 - Optimized with regards to the given borehole diameter
- Anchor shaft (tendon): GEWI® or rebar version
- Plate
 - GEWI® mechanical anchor: flat plate with conical through-hole
 - Mechanical rebar anchor: domed plate with round or long hole
- Nut
 - One-sided convex hexagonal nut, self-locking nut, or domed nut
 - Spherical washers and driver tools available on request
- Other dimensions, steel grades, and galvanized versions are available on request

Design Example GEWI® Mechanical Anchor

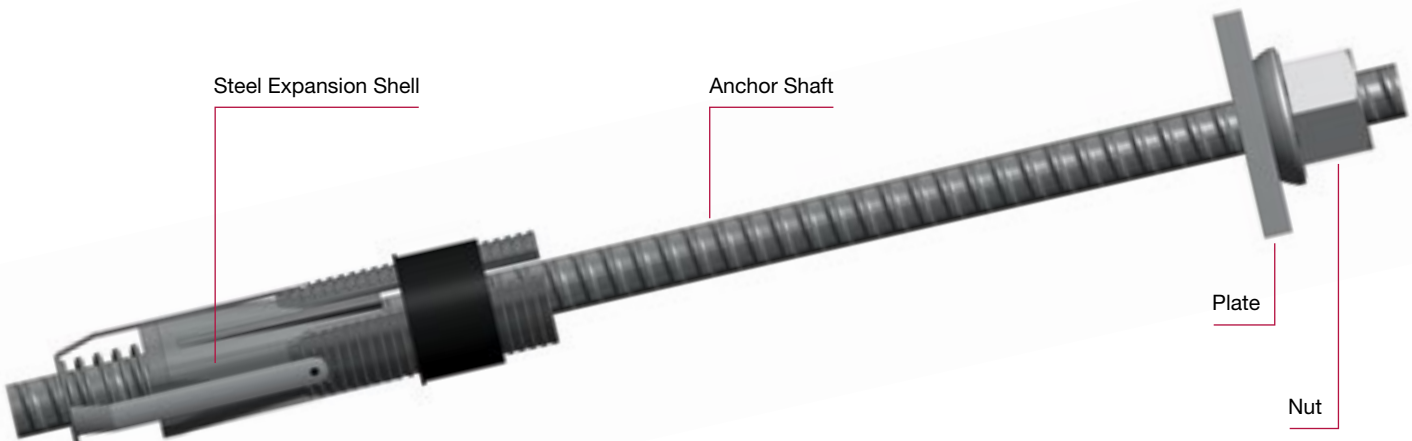

Mechanical Anchors

Specifications GEWI® Mechanical Anchors (SI Units)

Characteristics / Type	Unit	KS-145	KS-190	KS-220
Nominal diameter	[mm]	16.2	18	20
Nominal weight	[kg/m]	1.62	2.00	2.46
Nominal cross-section	[mm ²]	207	254	314
Yield strength ¹⁾	[N/mm ²]	450	670	500
Tensile strength ¹⁾	[N/mm ²]	700	800	700
Ultimate load ²⁾	[kN]	145	190	220
Ultimate elongation A ₅ ¹⁾	[%]	15	15	15
Nut version ³⁾	[-]	S, H	K	K
Borehole diameter ⁴⁾	[mm]	34 - 36	44 - 47	44 - 47

1) Steel tendon (anchor shaft)

2) Anchor system: anchor bar, plate, and nut

3) H = hex nut, one-sided convex seat; S = stop nut; K = domed nut

4) Standard version expansion shell

Specifications Mechanical Rebar Anchors

- SI units
 - Smooth or ribbed reinforcing steel
 - Steel grade B 500 B according to DIN 488-1 or OENORM B 4700; alternative steel grades available on request
 - Standard bar sizes 16 [mm] and 20 [mm]
 - Different expansion shell types and diameters available on request
- US customary units
 - Standard sizes 5/8", 3/4", and 7/8"
 - In accordance with ASTM F432 or CSA M430 specifications

Installation Procedure

- Drilling of a borehole in accordance with the specifications, approx. 150 [mm] (6 [in]) longer than the mechanical anchor when installed
- Insertion of the readily assembled mechanical anchor into the borehole – the expansion shell shall fit tight into the borehole
- Pre-tensioning with a impact screw driver or adequate driver tool
- Optional post grouting using a factory-fitted injection hose

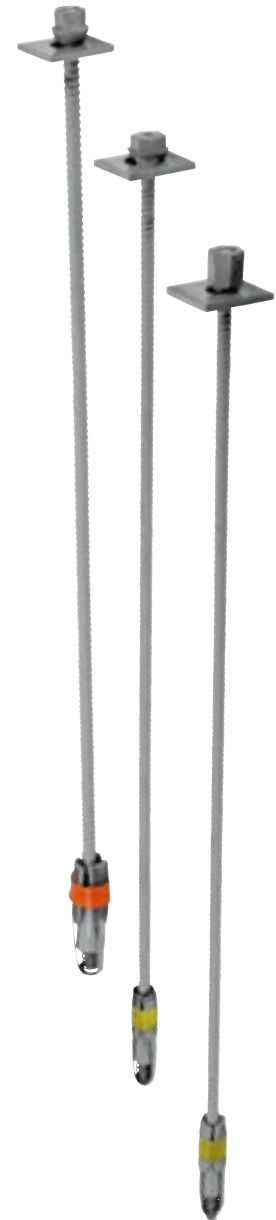

THREADBAR

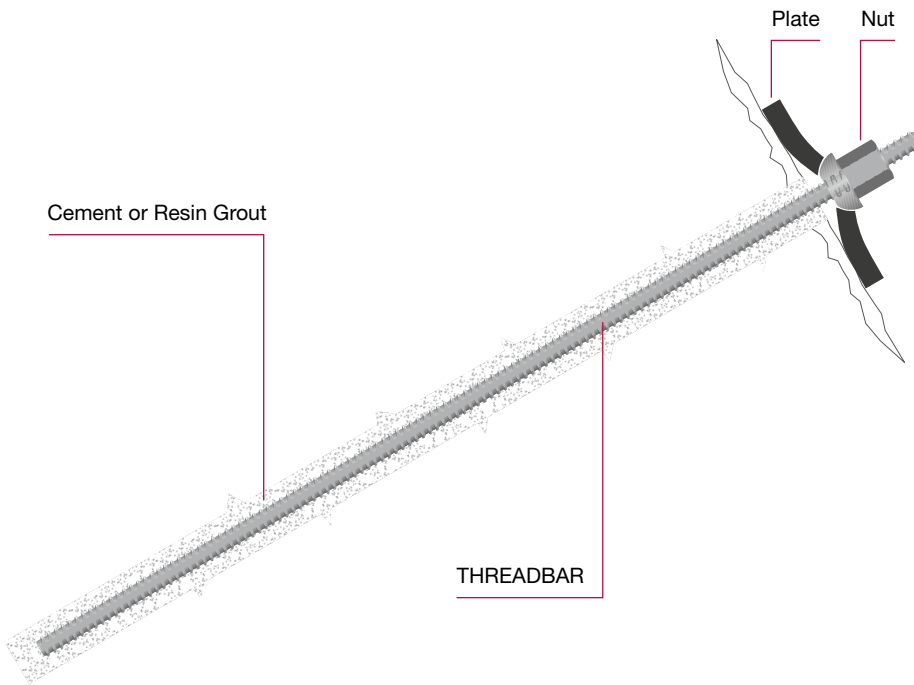

Main Advantages

- Optimized ratio of bolt capacity to borehole diameter
- Continuous threaded bar allows length adjustment and subsequent extension on-site
- Wear-resistant coarse thread according to the requirements in Tunneling



System Components

- **THREADBAR**
 - With right or left hand coarse thread
 - Optional extension using couplings
- **Plate**
 - Domed or flat
- **Nut**
 - Domed or hexagonal
 - Eye bolts available on request
- Double corrosion-protected version and free length systems with jacket tube available on request
- Steel expansion shell available on request

Specifications SI Units

Type	Nominal Diameter [mm]	Cross-Sectional Area [mm ²]	Yield Strength [N/mm ²]	Tensile Strength [N/mm ²]	Yield Load [kN]	Ultimate Load [kN]
GEWI® - left-hand thread	16	201	500	550	101	111
	20	314	500	550	157	173
	25	491	500	550	245	270
	28	616	500	550	308	339
	32	804	500	550	402	442
	40	1,257	500	550	628	691
	50	1,963	500	550	982	1,080
GEWI® Plus - right-hand thread	18	254	670	800	170	204
	22	380	670	800	255	304
	25	491	670	800	329	393
	28	616	670	800	413	493
	30	707	670	800	474	565
	35	962	670	800	645	770
	43	1,452	670	800	973	1,162
	57.5	2,597	670	800	1,740	2,077

THREADBAR

Torque-Tension Relationship

GEWI® Ø 25 [mm]

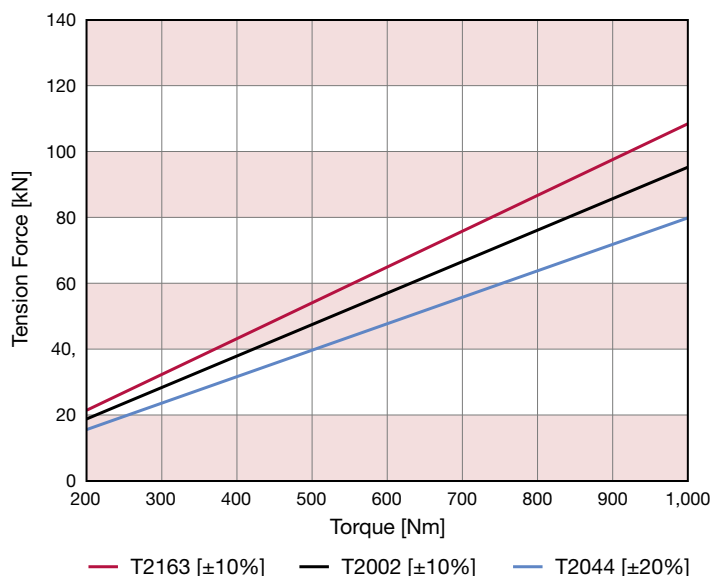

GEWI® Ø 28 [mm]

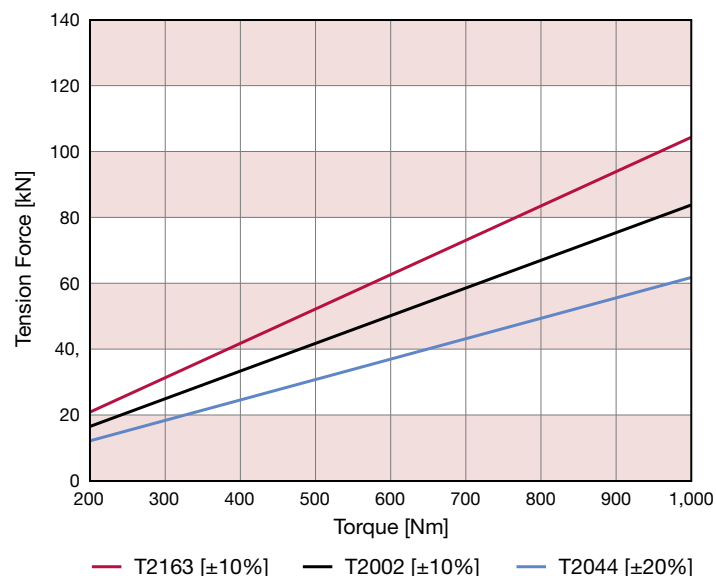

T2044



T2163



T2002



Specifications US Customary Units ¹⁾

Type	Designation	Maximum Outer Diameter	Cross-Sectional Area	Yield Strength	Nominal Yield Load	Nominal Weight
	[-]	[in]	[in ²]	[ksi]	[kip]	[lb/ft]
THREADBAR Grade 75/80	#6	0.86	0.44	75	33.0	1.50
	#7	0.99	0.60	75	45.0	2.04
	#8	1.12	0.79	75	59.3	2.67
	#9	1.26	1.00	75	75.0	3.40
	#10	1.43	1.27	75	95.3	4.30
	#11	1.61	1.56	75	117.0	5.31
	#14	1.86	2.25	80	180.0	7.65
THREADBAR Grade 100	#6	0.86	0.44	100	44.0	1.50
	#7	0.99	0.60	100	60.0	2.04
	#8	1.12	0.79	100	79.0	2.67
	#9	1.26	1.00	100	100.0	3.40
	#10	1.43	1.27	100	127.0	4.30
	#11	1.61	1.56	100	156.0	5.31
	#14	1.86	2.25	100	225.0	7.65

1) Reinforcing steel according to ASTM A615

Rebar Bolts (SN-Anchors)

Main Advantages

- Field-proven bolting system
- Effective and standardized installation
- Embedding of the tension member in grout ensures optimal bond strength
- Low sensitivity concerning the actual diameter of the borehole
- ALWAGRIP special rib geometry for optimized bond strength available on request



System Components



- Bolt shaft (tendon)
 - Pointed or 45° cut, with cold-rolled thread at the far end, including nut and washer
 - Standard thread length approx. 120 [mm] (5 [in])
 - Special ALWAGRIP rib geometry for increased bond available
- Plate
 - Default bolt plate: domed, with long hole
 - Other bolt plates in different dimensions available on request
- Washer and nut
 - Bolt head version with hemispherical washer available on request
 - Optional free length using a sleeve



Rebar Bolts (SN-Anchors)

Specifications SI Units

Characteristics / Type ¹⁾	Symbol	Unit	SN20-180	SN25-250	SN25-330	SN28-330
Nominal diameter	$D_{e,nom}$	[mm]	20	25	25	28
Thread	-	[mm]	M21	M26	M26	M30
Nominal cross-section rebar ²⁾	S_0	[mm ²]	315	490	490	615
Nominal weight rebar ³⁾	m	[kg/m]	2.47	3.85	3.85	4.83
Yield load rebar ⁴⁾	$F_{e,nom}$	[kN]	173	245	319	308
Ultimate load rebar ⁴⁾	$F_{m,s,nom}$	[kN]	190	260	340	330
Yield strength rebar ⁵⁾	$R_{e,nom}$	[N/mm ²]	550	500	650	500
Tensile strength rebar ⁶⁾	$R_{m,s,nom}$	[N/mm ²]	594	540	820	540
Ultimate elongation rebar ⁵⁾	A_{gt}	[%]	5.0	5.0	5.0	5.0
Ultimate load bolt system ⁷⁾	$F_{m,A,nom}$	[kN]	180	250	330	330
Recommended wall thickness plate	s	[mm]	8	10	12	12
Wrench size nut	SW	[mm]	36	41	41	46
Delivery lengths ⁸⁾	L	[mm]	1,000 - 12,000			

1) Status: 2016-04, note: all values are subject to change; other dimensions and steel grades available on request

2) Calculated from the nominal weight: $S_0 = 10^6 \times m / 7,850$ [kg/m²]

3) Characteristic fractile value

4) Calculated from the characteristic load value and nominal weight, rounded

5) Reinforcement steel B 500 B according to DIN 488-1 or OENORM B 4700; B 550 B according to OENORM B 4700; rock bolt steel FA 650/820

6) Calculated from the ratio R_m/R_e , or according to manufacturer specifications

7) Nominal value ultimate system load: bolt head with cold-rolled thread, plate, washer, and nut

8) Off-size lengths are available on request

Specifications US Customary Units

Characteristics / Type ¹⁾	Symbol	Unit	#6	#7	#8
Nominal diameter ²⁾	$D_{e,nom}$	[in]	0.750	0.875	1.0
Thread	-	[in]	3/4" - 10 UNC	7/8" - 9 UNC	1" - 8 UNC
Yield load rebar	$F_{e,nom}$	[lb]	20,000	27,700	36,400
Ultimate load rebar	$F_{m,s,nom}$	[lb]	30,100	41,600	54,500
Ultimate elongation	A	[%]	> 9		

1) In accordance with ASTM F432 or CSA M430 specifications

2) Deviating rebar sizes available on request



Rebar Bolts (SN-Anchors)

Installation Accessories

- Nuts
 - Plain
 - Domed
 - Flange
 - With shear pin (drive nuts)



- Washers
 - Round
 - Steel or plastic versions
 - Spherical seat: angle compensation
- Torque indicators and plates
 - See section accessories



- Installation tools
 - For hand-held drifters and hydraulic rock drills
 - Hex or square nut drivers
 - Torque or impact wrench
- Utility bolts
 - Eye nuts available on request



Installation Procedure

- Borehole drilling
- Filling of the boreholes with grout
- Manual insertion of SN-Anchors into the pre-filled boreholes, fixation in the borehole using a wedge or similar device
- Curing time is to be adjusted to the applied grout or valid installation instructions
- Tensioning of the bolt's head by tightening of the nut



Rebar Bolts (SN-Anchors)

ALWAGRIP Special Rib Geometry

- According to the guideline RVS 8T, Federal Ministry for Transport, Innovation and Technology, Austria
- The rib geometry of conventional SN-Anchors is in accordance with the regulations of concrete steel reinforcement
- Ground deformations in Tunneling usually occur immediately after the installation of SN-Anchors, which is why the requirements for bond strength development differ from those for reinforced concrete construction
- Development of ALWAGRIP special rib geometry in accordance with the requirements for SN-Anchors in Tunneling, especially in squeezing ground conditions
- Obtained rib area between 0.02 and 0.04 (cf. RVS 8T, Federal Ministry for Transport, Innovation and Technology, Austria)
- Material characteristics of SN-Anchors with ALWAGRIP special rib geometry are considerably better than for similar anchors and bolts with concrete reinforcement ribbing
- The advantages of using a steel grade with higher yield strength are observable after a curing time of 12 hours

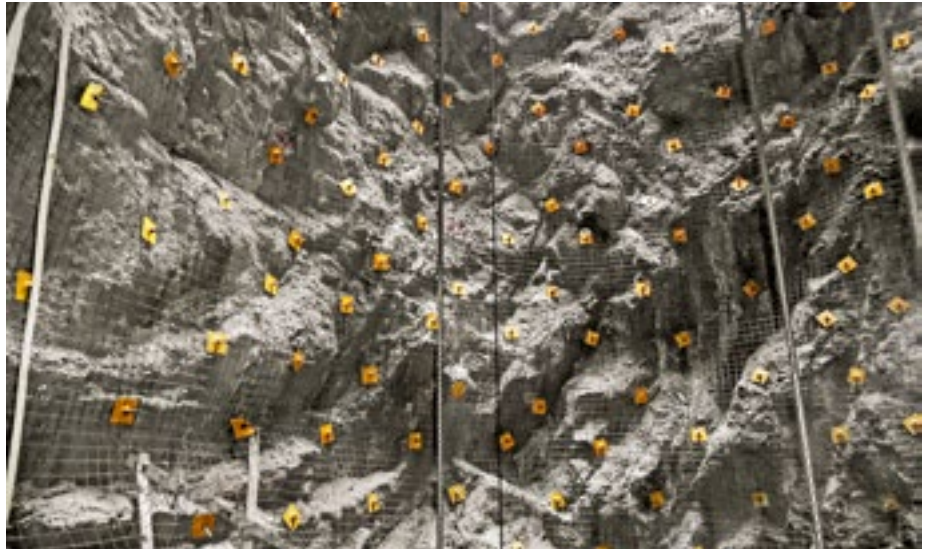

Further References

- Schubert, W. (Ed.): Recommendation – Fully mortared rock bolts (SN-Anchors) – Special Rib Geometry and requirements for the mortar; Institute of Rock Mechanics and Tunneling; Graz, Austria, 1997-07
- Blümel, M.: Bearing load of rock bolts in squeezing rock mass, Proceedings ISRM International Symposium EUROCK '96 Turin, Italy, Balkema Rotterdam, 1996
- Blümel, M.; Schweiger, H.F.; Golser, H.: Effect of Rib Geometry on the Mechanical Behaviour of Grouted Rock Bolts, Proc. of World Tunnel Congress '97, 23rd General Assembly of the International Tunnelling Ass., Vienna, Austria, 1997



Laboratory Pull Test Results

- Examination of the inner bond for two different bolt steel types depending on curing time
- Results of pull-out tests after 12 hours curing time, bond length 500 [mm]

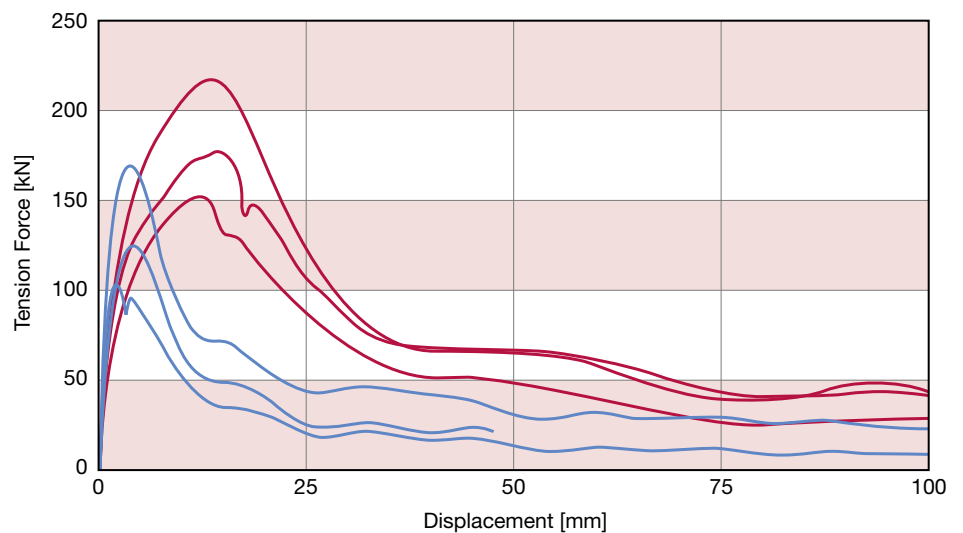

- Bolt steel Ø 25 [mm] FA 650/820 with ALWAGRIP special rib geometry
- Standard rebar steel Ø 25 [mm] B 500 B

DYWI® Drill Combination Bolts

DYWI® Drill S-D Expansion Bolt

The DYWI® Drill S-D (self-drilling) expansion bolt combines a hollow bar system with an expansion shell element. The entire bolt assembly is installed self-drilling, activation of the expansion element is achieved by pulling the hammer back under hydraulic strokes. Tensioning of the bolt head and subsequent grouting are accomplished in separate working steps.

This innovative system solution is successfully used for installing bolts in areas difficult-to-access and in ground conditions with unstable boreholes. An active pre-tensioning of the bolt combined with grouting through the hollow bar member enable this system to function as a combination bolt. Further information and specifications are included in the DYWI® Drill Hollow Bar System section.

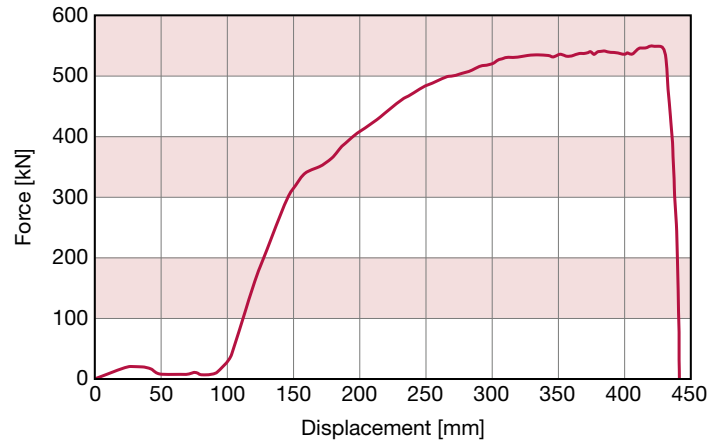

S-D expansion bolt type R38-076, R38-550
Determined in the course of laboratory pull tests in model rock mass (concrete)



DYWI® Drill Expansion Shell Bolt

The DYWI® Drill expansion shell bolt combines the benefits of a tensionable mechanical anchor featuring immediate support action and a fully grouted bolt. Based on the DYWI® Drill Hollow Bar System, the tendon consists of a hollow bar. Installation of the assembled bolt – including expansion shell, plate, and nut – is accomplished in a pre-drilled borehole. Optional post-grouting of the bolt is performed top down through the hollow bar.

Further information and specifications are included in the DYWI® Drill Hollow Bar System section.

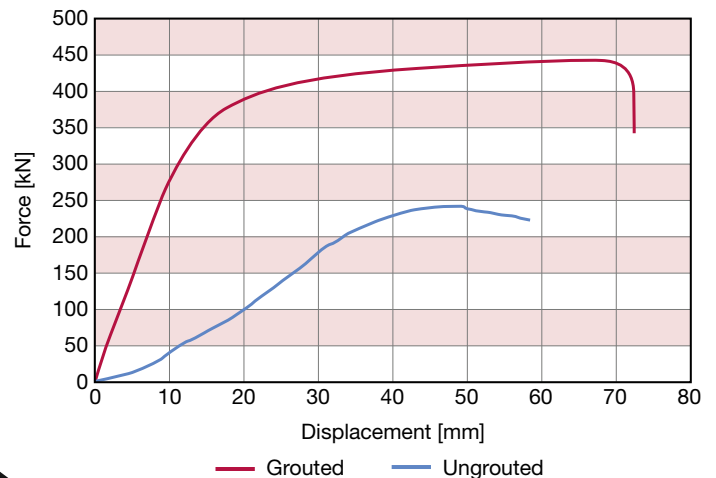

Expansion shell bolt type SK-R32-048, R32-400
Determined in the course of laboratory pull tests in model rock mass (concrete)



CT-Bolt™ Combination Bolts

Introduction

The CT-Bolt™ is a unique combination bolt system. It offers the combined advantages of an immediate mechanical point anchorage and subsequently a fully grouted bolt. A two-step installation procedure allows fast installation and immediate anchorage; separate and

independent grouting provides flexibility in terms of working cycles.

Due to the controlled grouting procedure and different bar coatings available, the CT-Bolt™ is a reliable ground control system for Underground applications.

The working ability of the CT-Bolt™ has been proven throughout various Underground projects; the system has become a standard in today's state-of-the-art ground control procedures.

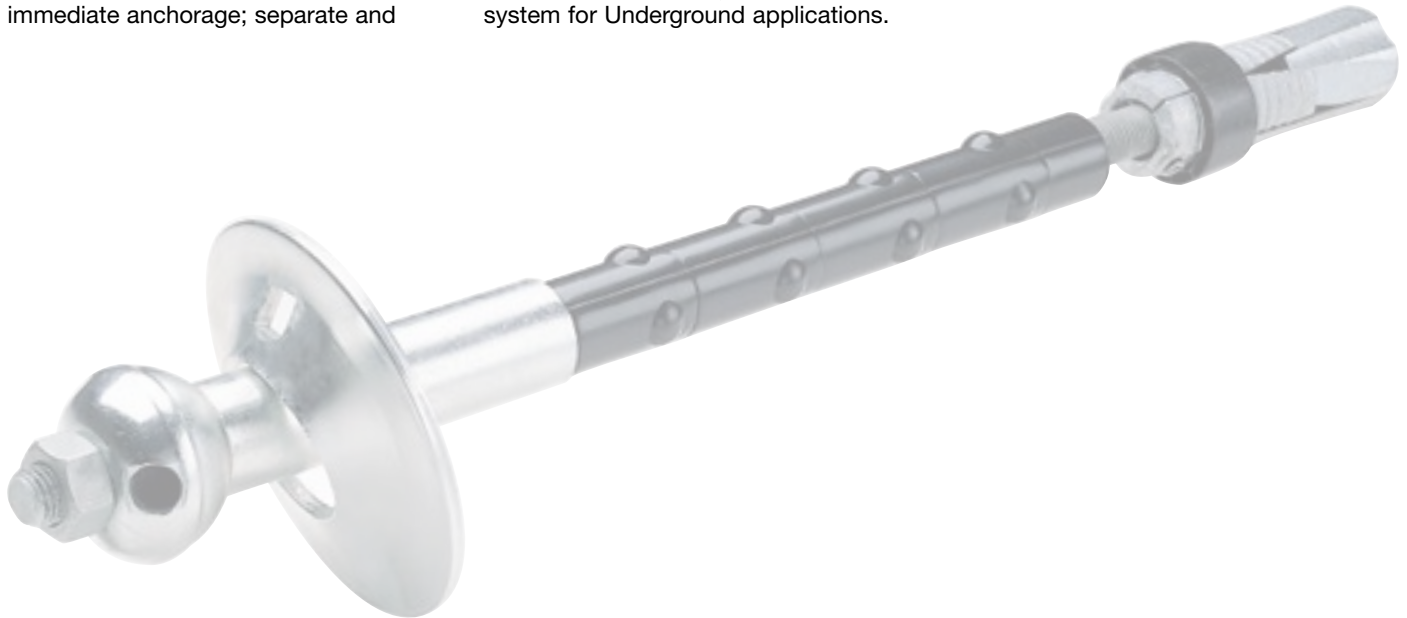

Main Advantages

- Efficient, practically proven, and reliable rock reinforcement system
- Combination of an immediate mechanical point anchorage and a fully grouted bolt
- Immediate load-bearing capacity of the mechanical anchor after installation
- Fast installation and flexible post-grouting behind the working face
- Double corrosion protection due to a polyethylene sleeve and grout coverage
- Easy adjustment of the corrosion protection level to customer demands
- Semi-automated or manual installation procedure

System Description

- Combination bolt
- Immediate mechanical point anchorage by activation of an expansion shell
Pre-tensionable
- Post-grouting assembly features double corrosion protection



CT-Bolt™ Combination Bolts

System Components

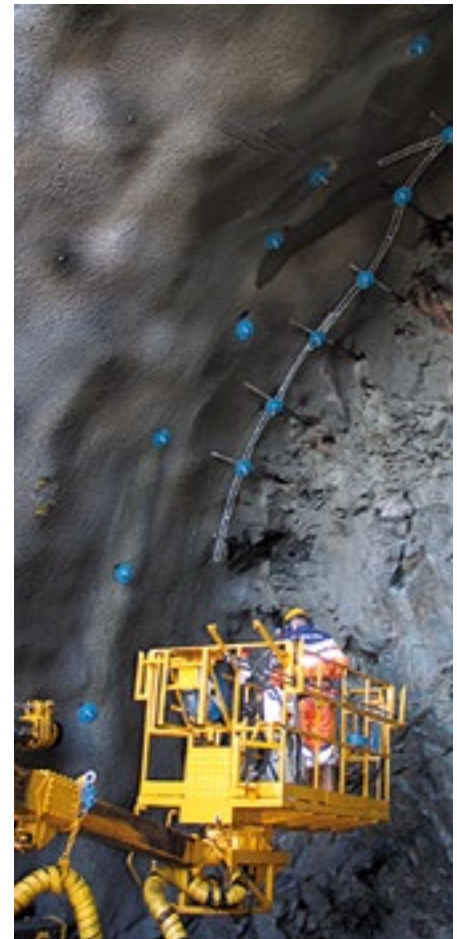

Specifications

Characteristic Value / Type		Unit	CT-M20	CT-M22	CT-M33
Rebar diameter		[mm]	20	21.7	32
		[in]	0.8	0.9	1.3
Thread designation		[mm]	M20	M22	M33
Mechanical anchor	Yield load ¹⁾	[kN]	123	168	302
		[kip]	28	38	68
	Ultimate load ²⁾	[kN]	147	211	342
		[kip]	33	47	77
Grouted combination bolt	Yield load ¹⁾	[kN]	157	226	383
		[kip]	35	51	86
	Ultimate load ²⁾	[kN]	188	282	440
		[kip]	42	63	99
Borehole diameter range		[mm]	45 - 52	45 - 48	63 - 67
		[in]	1.8 - 2.0	1.8 - 1.9	2.5 - 2.6

1) Calculated value with a safety factor of 1.15 against the yield strength (thread cross-section)

2) Calculated value with a safety factor of 1.05 against the ultimate strength (rebar cross-section)

CT-Bolt™ Combination Bolts

Installation Procedure

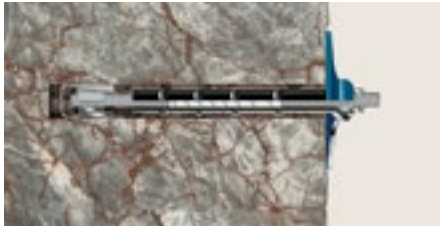

Borehole Drilling

- Drilling of a borehole: Ø 44 - 51 [mm] (1.7 - 2.0 [in])
- Recommended borehole length: about 100 [mm] (4 [in]) longer than the bolt length

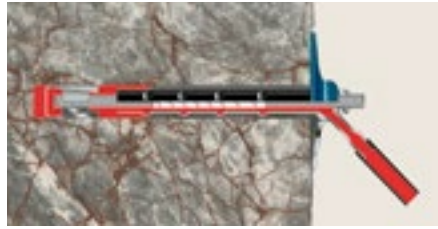

Bolt Installation

- Insertion of the assembled CT-Bolt™ into the pre-drilled borehole
- Pressing of the bolt plate firmly against the excavation surface
- Activation of the expansion anchor by pre-stressing of the anchor nut provides immediate mechanical point anchorage
- Typical required torque: 200 - 300 [Nm] (150 - 220 [lbf·ft])

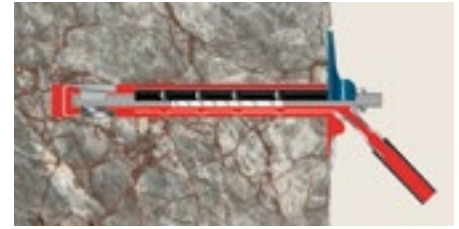

De-Coupled Bolt Grouting

- Preparation of cement grout according to given specifications
- Connection of an injection adapter to the grouting adapter of the CT-Bolt™
- Primary grout flow inside the sleeve towards the bolt's toe (expansion shell) – complete grout coverage of the rebar
- Secondary grout flow outside the sleeve until the grouting medium flows out at the bore for grout discharge at the hemispherical bolt plate

Accessories

- Load indicators
- Bolt testing equipment

Technical Features

Combination Bolt

- Active reinforcement by pre-stressing of the expansion shell anchor
- Allowance of a certain amount of elastic deformation of the rebar induced by displacements of the ground
- Flexible grouting behind the working face allows an optimum adaptation of the CT-Bolt™ to given ground and operating conditions
- Optimum alignment and complete grout coverage of the bolt are ensured by the polyethylene sleeve



Unique Choice of the Corrosion Protection Level

- Protection of the CT-Bolt™ components according to given levels of corrosive environments
- Bolts are available black, hot-dip galvanized, or with a special Combi Coat® (combination of hot-dip galvanizing, zinc phosphate, and powder coating)
- Indicated lifetimes for load-bearing components of the fully-grouted CT-Bolt™ by accelerated corrosion tests from 50 years (black type) to 150 years (Combi Coat® type)

Resin Cartridges

Introduction

Resin cartridges are used to bond bolts to the surrounding ground. Cartridge diameter and length must be optimized to bolt length as well as borehole and bolt diameter.

System Description

Resin cartridges consist of two compartments: one containing resin, the other one a catalyst. Separation of those two compartments is accomplished by a head-sealed polyester film tube clipped at both ends. This chemical resistant film tube prevents migration between the resin and the catalyst, and features an optimum shelf life. Hence, the film shreds quickly during the installation process.

Resin cartridges are thixotropic and fast setting, allowing a low installation force and torque.

Specifications

- Nominal diameters for both SI Units and US Customary Units
- Cartridges are available in lengths from 300 [mm] to 1,525 [mm] (12 [in] to 60 [in])
- Deviating dimensions available on request
- Standard gel times: 15 - 400 seconds
- Alternative gel times available on request
- Spin times depending on resin cartridge type
- Storage temperature must be lower than 30 [°C] (86 [°F]), default shelf life one year
- Standard diameters EU: 25, 28, and 32 [mm]

Standard Diameters North America

[mm]	[in]
23	0.9"
25	1"
28	1 1/8"
29	1 9/64"
30	1 3/16"
32	1 1/4"
35	1 3/8"
40	1 9/16"

Bonding can either be accomplished using resin cartridges with the same setting (gel) time, or cartridges with different gel times allowing pre-tensioning of a bolt.

Main Advantages

- Maximum bonding capacity due to optimized components
- Optimized installation times
- Durable and sound resin grouting
- Constant and customized gel times
- Water-based resin cartridge system
- High catalyst/resin ratio
- Suitable for all ground types with stable boreholes



Resin Cartridges

Installation Procedure

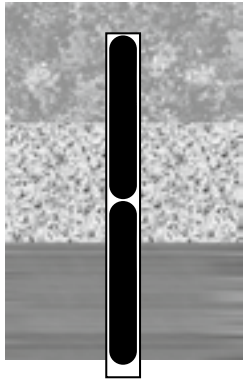

1. Insertion of required resin cartridges into the borehole.

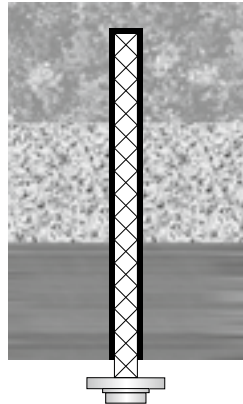

2. Insertion of the bolt into the hole to a point just below the excavation line. Slow rotation of the bolt during insertion is optional.

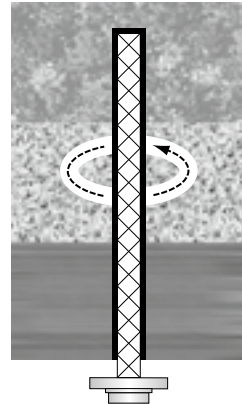

3. Bolt rotation. Note rotation speed and spin time recommendations.

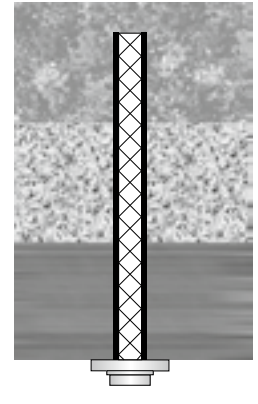

4. Push the bolt upward with the maximum thrust available from the machine and hold until the resin cartridges harden. Do not rotate after step 3 – damage to partially gelled resin may result.

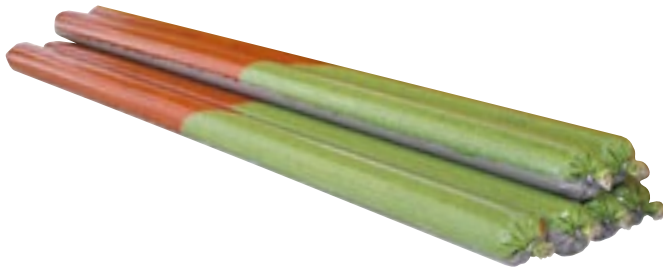

- Do not use ruptured or broken resin cartridges
- Recommended installation procedures should be followed carefully to ensure successful application of resin cartridges
- All instructions are general guidelines – on-site tests must be conducted to determine actual “mix” and “hold” times
- Additional technical and safety data is included in the material data sheets



Resin Cartridges

Resin Yield Chart for THREADBAR (North America)

	Resin Cartridge Diameter		0.90"	23	1 1/8"	29	1 1/8"	29	1 1/4"	32	1 1/8"	29	1 1/4"	32	1 3/8"	35	1 3/8"	35	1 1/16"	40
	[in]	[mm]	[in]	[mm]	[in]	[mm]	[in]	[mm]	[in]	[mm]	[in]	[mm]	[in]	[mm]	[in]	[mm]	[in]	[mm]	[in]	[mm]
Required Inches of Cartridge per Cured Foot as per ASTM F432																				
Grade 75 designation	#6	3/4"	9.7"																	
	#7	3/8"			10.6"				10.4"											
	#8	1"					10.3"		8.5"											
	#10	1 1/4"									9.8"		8.1"							
	#11	1 7/8"													10.9"					
	#14	1 3/4"															12.0"		8.9"	
Borehole diameter	-	-	1"	25	1 1/4"	32	1 3/8" / 35		1 1/2" / 38		1 3/4"		2" / 51							

Resin Cartridge Retainer Caps

System Description

- Bolting operations in high headings or caverns where a manual installation is not safe or practical
- Firm securing of resin cartridges in the borehole
- Installation with a multiple-use plastic insertion tube and a threaded adapter connected to the drifter
- Retainer caps keep the resin cartridge in the borehole

Main Advantages

- Resin cartridges can be placed in the borehole from a remote location under supported ground
- No requirement for loading baskets
- The resin cartridges reaches the back of the hole undamaged
- Default application with jumbos or bolters



Cement Cartridges

Introduction

Cement cartridges consist of a cementitious compound encased in a perforated package which, when immersed in water, will allow controlled wetting of contents, forming a thixotropic grout. The cartridge is then inserted into the hole and the deformed bolt or dowel is pushed in.

Main Advantages

- Convenient and easy-to-handle cartridge form
- Faster curing compared to standard cement grouts
- Controlled setting times and high-strength bonding
- Simple activation by immersion in water
- Thixotropic and non-shrinking performance
- No special grouting equipment required
- Non-toxic, non-combustible, and chloride free

Specifications ¹⁾

Characteristic Value / Type	Unit	CC-25	CC-28	CC-32	CC-35	CC-39
Outer diameter	[mm]	25	28	32	35	39
	[in]	1.0	1.1	1.3	1.4	1.5
Length	[mm]	600				
	[in]	23.6				
Soak time	[s]	60				

Characteristic Value / Type	Unit	2 Hours	4 Hours	1 Day	3 Days	7 Days
Compressive strength	[MPa]	12	14	21	35	43
	[psi]	1,740	2,030	3,050	5,080	6,240

1) Default shelf life 1 year

Installation Procedure

1. Remove required number of cartridges from the package.
2. Immerse cartridges in water until there are no signs of air release (bubbling) from the cartridge – do not leave in water for longer than 5 minutes.
3. The cement grout will begin to set in 20 minutes after initial water emersion; therefore the bolt must be installed within this time period. However, it is recommended that the wetted cartridges be used within 15 minutes to obtain optimum results.
4. Insert cartridges into a clean hole (tamp with a loading stick).
5. Insert the bolt, which will rupture the cartridges allowing the grout to fill the annular space between bolt and borehole. After 12 hours, the grout will typically withstand the full yield load of standard rebar bolts.

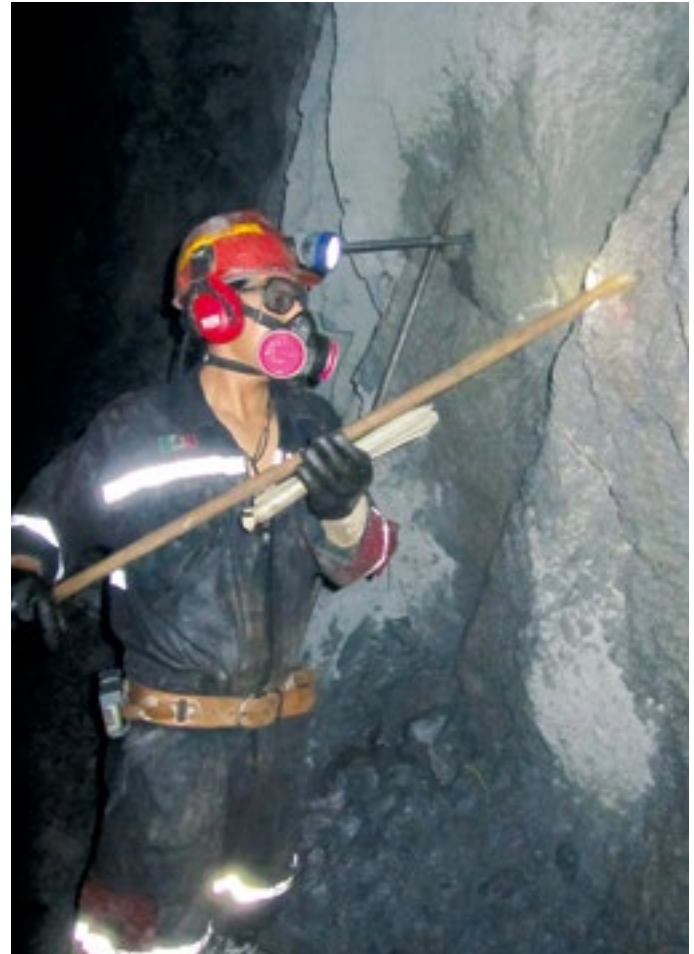

OMEGA-BOLT® Expandable Friction Bolts

Introduction

The main application of the OMEGA-BOLT® expandable friction bolt is temporary rock reinforcement for Underground applications.

Bonding forces between the friction bolt and the ground are caused by form closure (mechanical interlocking) and friction transfer between the borehole wall and the bolt, which is expanded by hydraulic pressure.

Main Advantages

- Immediate full load-bearing capacity over the entire installed bolt length
- Trouble-free installation in water-bearing boreholes
- Low sensitivity against vibrations caused by blasting works
- Ability to maintain load-bearing capacity even when undergoing deformations
- Safe and easy installation
- No additional building materials required for installation
- Flexibility in case of differing or varying borehole diameters
- Quality check during every single installation
- Different customized high-pressure pumps available



System Description

- Manual or automated installation by expansion of the omega-shaped profile with high-pressure water
- Frictional load transfer and mechanical interlocking between bolt and borehole
- Adjustment of the expanded profile to irregularities of the borehole wall and variations in borehole diameter
- OMEGA-BOLT® version “+” provides improved elongation properties
- Galvanized or epoxy coated versions available on request

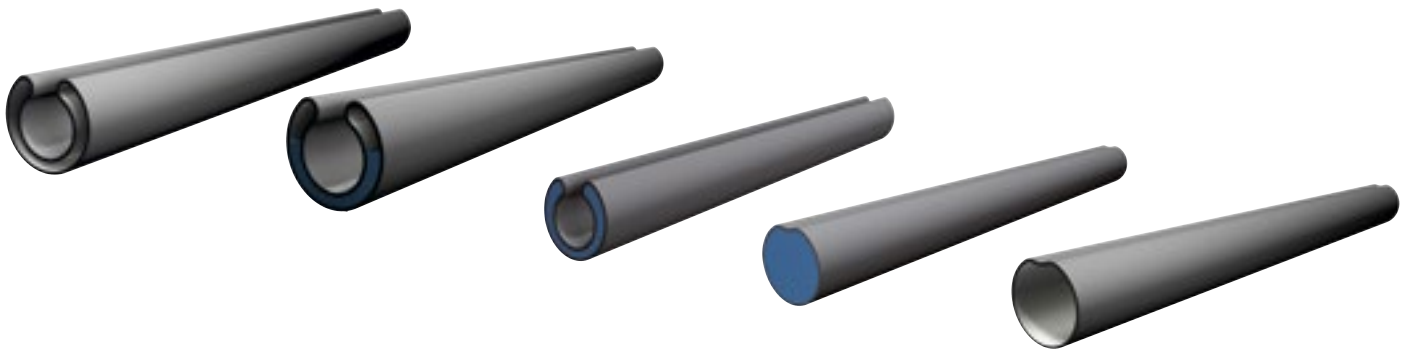

OMEGA-BOLT® Expandable Friction Bolts

System Components

- Bushing head
 - Flared, with inflation hole
- Domed plate
 - Different designs and dimensions available on request
- OMEGA-BOLT®
 - Upper bushing

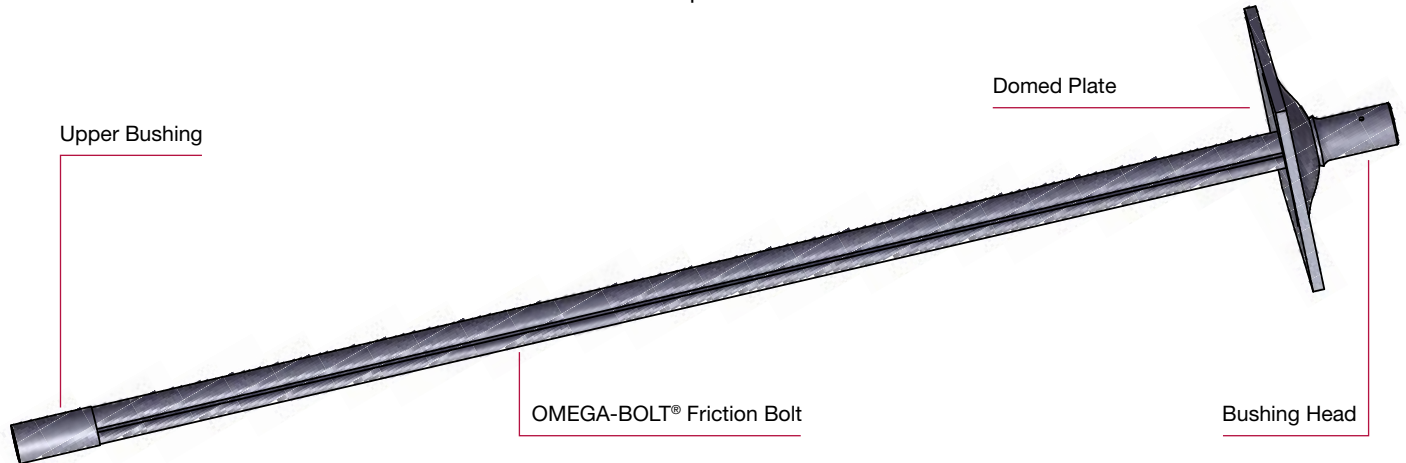

Specifications

SI Units							
Characteristic Value / Type ¹⁾	Unit	EFB-120	EFB-160	EFB-200	EFB-240	EFB-120+	EFB-240+
Yield load ²⁾	[kN]	100	140	180	220	90	170
Nominal ultimate load ²⁾	[kN]	120	160	200	240	120	230
Characteristical ultimate elongation ²⁾	[%]	10	10	10	10	30	30
Nominal ultimate elongation ²⁾	[%]	6	6	6	6	20	20
External diameter Ω profile ³⁾	[mm]	26	36	36	36	27.5	36
External diameter original tube	[mm]	41	54	54	54	41	54
Wall thickness	[mm]	2	2	2.5	3	2	3
Diameter bushing head	[mm]	30	41	41	41	30 / 36	41 / 48
Diameter upper bushing	[mm]	28	38	38	38	28	38
Required borehole diameter	[mm]	32 - 40	45 - 53	45 - 53	45 - 53	32 - 39	43 / 52
Optimum borehole diameter	[mm]	36 - 39	48 - 52	48 - 52	48 - 52	35 - 38	45 / 51
Inflation pressure	[bar]	260	260	300	300	300	300
Delivery lengths ⁴⁾	[m]	2.0 to 12.0				1.0 - 8.0	

US Customary Units							
Characteristic Value / Type ¹⁾	Unit	EFB-120	EFB-160	EFB-200	EFB-240	EFB-120+	EFB-240+
Yield load ²⁾	[kip]	22	31	40	49	20	38
Nominal ultimate load ²⁾	[kip]	27	36	45	54	27	52
Characteristical ultimate elongation ²⁾	[%]	10	10	10	10	30	30
Nominal ultimate elongation ²⁾	[%]	6	6	6	6	20	20
External diameter Ω profile ³⁾	[in]	1.0	1.4	1.4	1.4	1.1	1.4
External diameter original tube	[in]	1.6	2.1	2.1	2.1	1.6	2.1
Wall thickness	[in]	0.08	0.08	0.10	0.12	0.08	0.12
Diameter bushing head	[in]	1.2	1.6	1.6	1.6	1.2 / 1.4	1.6 / 1.9
Diameter upper bushing	[in]	1.1	1.5	1.5	1.5	1.1	1.5
Required borehole diameter	[in]	1.3 - 1.6	1.8 - 2.1	1.8 - 2.1	1.8 - 2.1	1.3 / 1.5	1.7 / 2.0
Optimum borehole diameter	[in]	1.4 - 1.5	1.9 - 2.0	1.9 - 2.0	1.9 - 2.0	1.4 / 1.5	1.8 / 2.0
Inflation pressure	[psi]	3,770	3,770	4,350	4,350	4,350	
Delivery lengths ⁴⁾	[ft]	6.6 - 39.4				3.3 - 26.2	

1) Status: 2016-04; OMEGA-BOLT® expandable friction bolts with different characteristic values are available on request

2) Expanded profile

3) Tolerance: +1 [mm] (+ 0.04 [in])

4) Off-size lengths are available on request

OMEGA-BOLT® Expandable Friction Bolts

Installation Procedure

1. Borehole drilling.



2. Connection to the installation chuck and insertion of the OMEGA-BOLT® into the borehole.



3. Expansion of the OMEGA-BOLT® with high-pressure water.



4. De-coupling from the chuck after the OMEGA-BOLT® is fully widened.



OMEGA-BOLT® Expandable Friction Bolts

OMEGA-BOLT® High-Pressure Pumps

System Description

The installation equipment for the OMEGA-BOLT® consists of the following components:

- OMEGA-BOLT® high-pressure pump (water pump and motor)
- High-pressure hose
- Setting arm with setting head and chuck

After insertion of the OMEGA-BOLT® into the borehole, the setting arm is fitted to the bolt's head. By operating the valve lever on the setting arm, the bolt is hydraulically expanded (unfolded) using high-pressure water, which is induced into the inside of the folded bolt tube. After reaching the defined maximum setting pressure, the valve lever is released and the setting head is pulled away from the bolt's head.

Main Advantages

- Tough design and easy handling
- Fast installation due to high pump performance
- Optimum expansion of the OMEGA-BOLT® is ensured
- Alternative high-pressure pumps available on request
- OMEGA-BOLT® pull test kit available on request



Specifications Electric Pump Type 300E (SI Units)

Characteristics	Unit	Value
Dimensions (L x W x H)	[mm]	800 x 400 x 455
Weight	[kg]	90
Max. flow rate	[l/min]	21
Operating pressure ¹⁾	[bar]	300
Max. operating pressure	[bar]	320
Power supply ²⁾	[V]	3 ~ 400
Nominal power ²⁾	[kW]	11
Electrical connection ²⁾	[A]	25
Pumping rotation speed	[rpm]	1,400

1) Required tube connection 3/4", water connection pressure: 2 [bar]

2) According to IEC 60309 (not CSA approved). Other electric pumps are available on request

Specifications Pneumatic Pump (US Customary Units)

Characteristics ¹⁾	Unit	Value
Dimensions (L x W x H)	[in]	32.3 x 12.6 x 13.4
Weight	[lb]	73
Max. flow rate	[gal/min]	1
Operating pressure	[psi]	2,000
Max. water pressure	[psi]	6,300
Required air pressure	[psi]	70 - 100
Air to water pressure ratio	[1]	1:60

1) Other pneumatic pumps are available on request



POWER SET Self-Drilling Friction Bolts

Introduction

The POWER SET self-drilling (S-D) friction bolt is a self-drilling ground control element used for Underground applications. In addition, the POWER SET bolt system is deployed for rock fall and rock slide protection.

This patented one-step POWER SET bolt system stands for a safe and easy installation as well as immediate load-bearing capacity after installation. Another feature is the flexibility of the POWER SET regarding changing ground conditions.

Optional installation of an expansion element features additional mechanical anchorage up to the ultimate load of the friction bolt tube. A specially developed automation unit for six bolts per installation sequence allows a safe and state-of-the-art bolt installation.



Main Advantages

- Simultaneous drilling and installation
- Installation using standard drilling machinery
- Immediate load-bearing capacity after installation
- Direct load transfer over the entire bolt length
- Ability to maintain load-bearing capacity even when undergoing large deformations
- High shear strength
- Safe, easy, and fast installation procedure
- Trouble-free application under unstable borehole conditions
- No additional building materials such as grout, chemicals, or water required
- Ergonomic and safety-related advantages for the workforce

System Description

- Improved self-drilling friction bolt
- Frictional load transfer between bolt and borehole
- Application for bolting in remote areas or in case of unstable ground conditions
- Installation with standard rotary-percussive rock drilling equipment: controlled transfer of impact energy onto the friction bolt
- Optional installation of an expansion element: increase of the load-bearing capacity up to the ultimate load of the friction bolt tube
- Sacrificial corrosion protection for extended working life by increased friction bolt wall thickness
- Non-sensitive to nearby blasting works



POWER SET Self-Drilling Friction Bolts

System Components

- POWER SET drill bit
 - Single-use drill bit available in different designs and dimensions, depending on ground conditions
- POWER SET drill rod
 - High-performance drill steel for optimum service life
- POWER SET adapter
 - Controlled transfer of the impact energy onto the friction bolt
- Domed plate
 - Different designs and dimensions available on request
- POWER SET friction bolt
 - Slotted tube with bolt head and tapered end

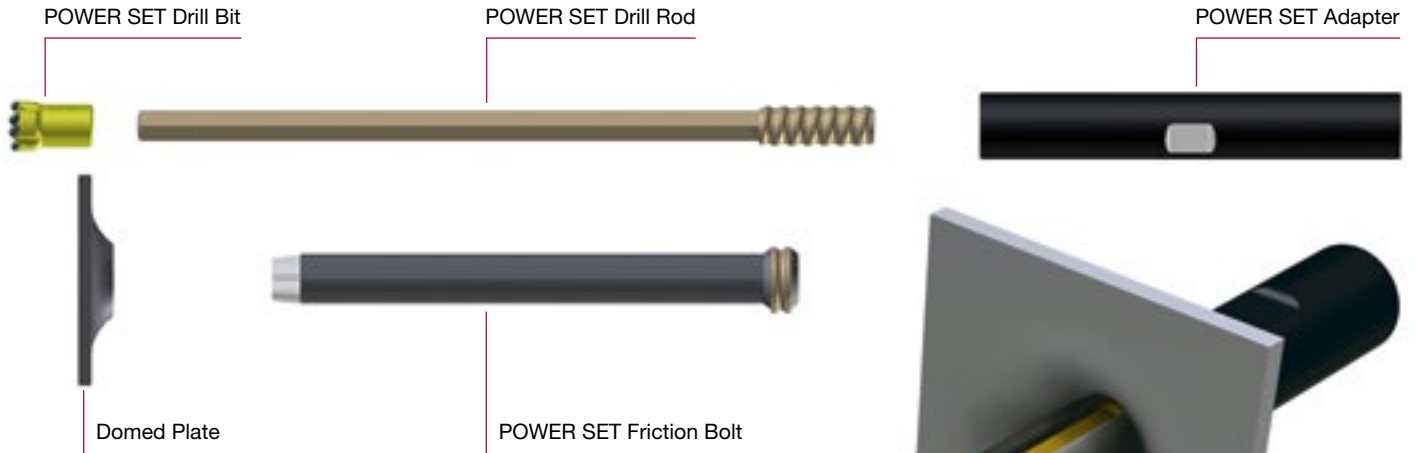

Ready-For-Use POWER SET Self-Drilling Friction Bolt

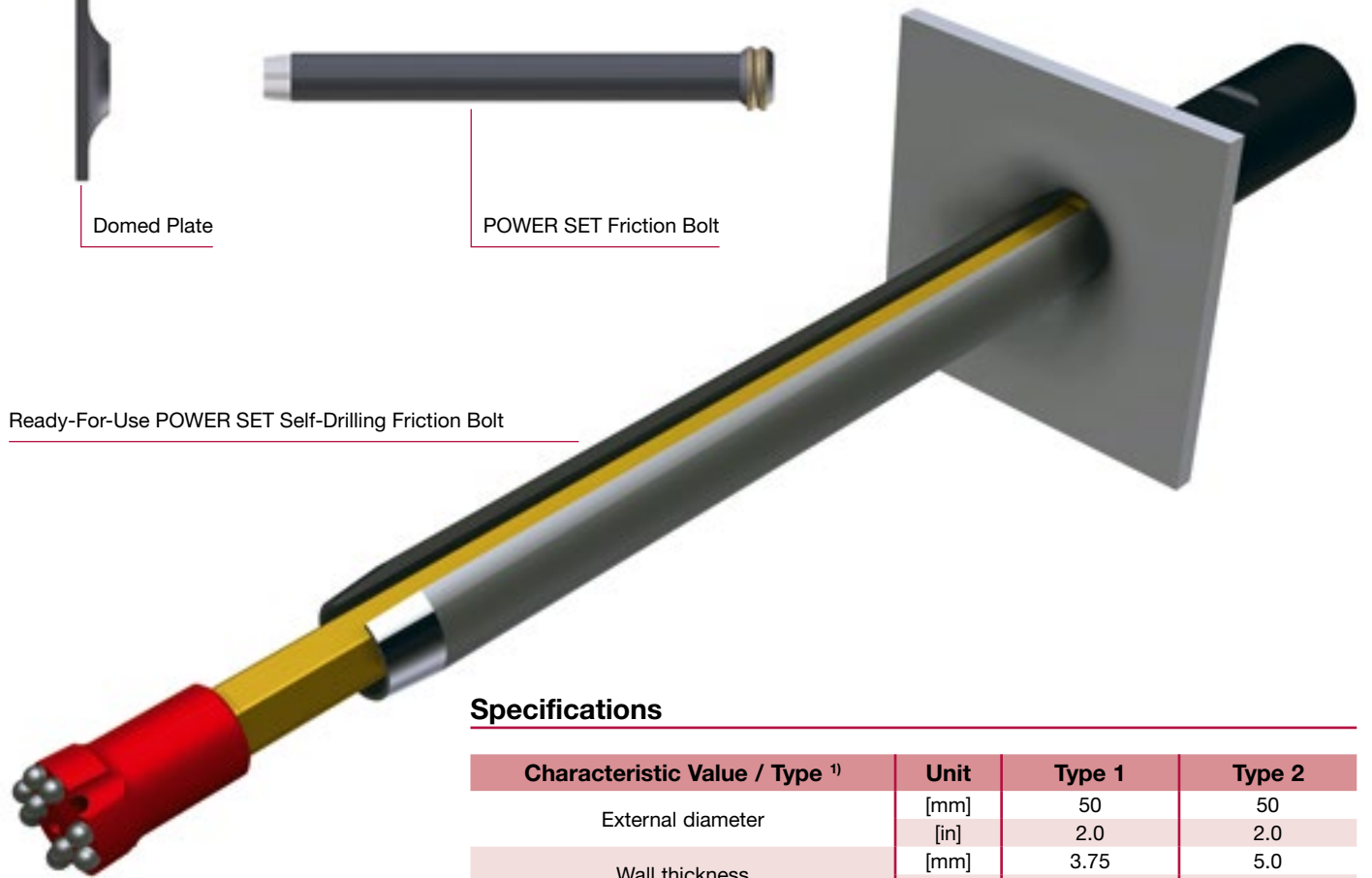

Specifications

Characteristic Value / Type ¹⁾	Unit	Type 1	Type 2
External diameter	[mm]	50	50
	[in]	2.0	2.0
Wall thickness	[mm]	3.75	5.0
	[in]	0.15	0.20
Nominal cross-section ²⁾	[mm ²]	470	600
	[in ²]	0.73	0.93
Ultimate load ³⁾	[kN]	330	300
	[kip]	74	67
Ultimate strength	[N/mm ²]	700	500
	[ksij]	102	73
Guiding value shear force ⁴⁾	[kN]	370 - 470	360 - 420
	[kip]	83 - 106	81 - 94
Delivery lengths ⁵⁾	[m]	1.0 - 4.0	
	[ft]	3.3 - 13.1	

1) Status: 2016-04, note: all values are subject to change

2) Rounded

3) Calculated from the characteristic load value and nominal cross-section, rounded

4) In-situ value for installed bolts

5) Customized lengths are available on request

POWER SET Self-Drilling Friction Bolts

POWER SET Drill Bits

- Tuned to ground conditions and applications
- Different drill bit diameters allow an optimum on-site adaption
- Drill bit types
 - Standard version with carbide inserts
 - Hardened version available on request
 - Cross drill bit
 - Button drill bit
- Diameter colour code
 - RED: 47.5 [mm] (1 7/8 [in])
 - YELLOW: 48.5 [mm] (1 29/32 [in])
 - BLUE: 49.5 [mm] (1 61/64 [in])



Installation Procedure



1. Assembly of the POWER SET self-drilling friction bolt and connection of the adapter to the rock drill.



2. Rotary-percussive self-drilling installation with a single-use drill bit; back-flushing of the cuttings through the inside (annulus between drill steel and friction bolt).



3. Completion of installation after the final drilling depth has been reached.



4. Retraction of the POWER SET drill rod from the installed friction bolt – the single-use drill bit remains inside.



5. Optional installation of an expansion element.



6. Mechanical anchorage of the POWER SET friction bolt by enlargement of the expansion element using hammer strokes of the rock drill.



7. Retraction of the POWER SET drill steel.

POWER SET Automation Unit

Introduction

The POWER SET automation unit is used for the fully automated installation of the POWER SET self-drilling friction bolt. This independent boom unit can be attached to Underground drilling or continuous excavation machines;

alternatively, it can be mounted onto support frames.

Featuring a bolt magazine, fully automated installation of six POWER SET self-drilling friction bolts

per bolt operation cycle can be achieved. The combination of a friction bolt with optional additional point end anchorage and remote-controlled installation is ideal for bolting under difficult and unstable ground conditions.

Main Advantages

- Fast and safe installation of the POWER SET self-drilling friction bolt
- No personnel has to be present in unsupported areas
- Fully remote-controlled and automated installation
- Tough design for Underground applications
- Easy and similar operating principle using standard personnel and on-site drilling machinery
- Proven installation procedure under difficult ground conditions

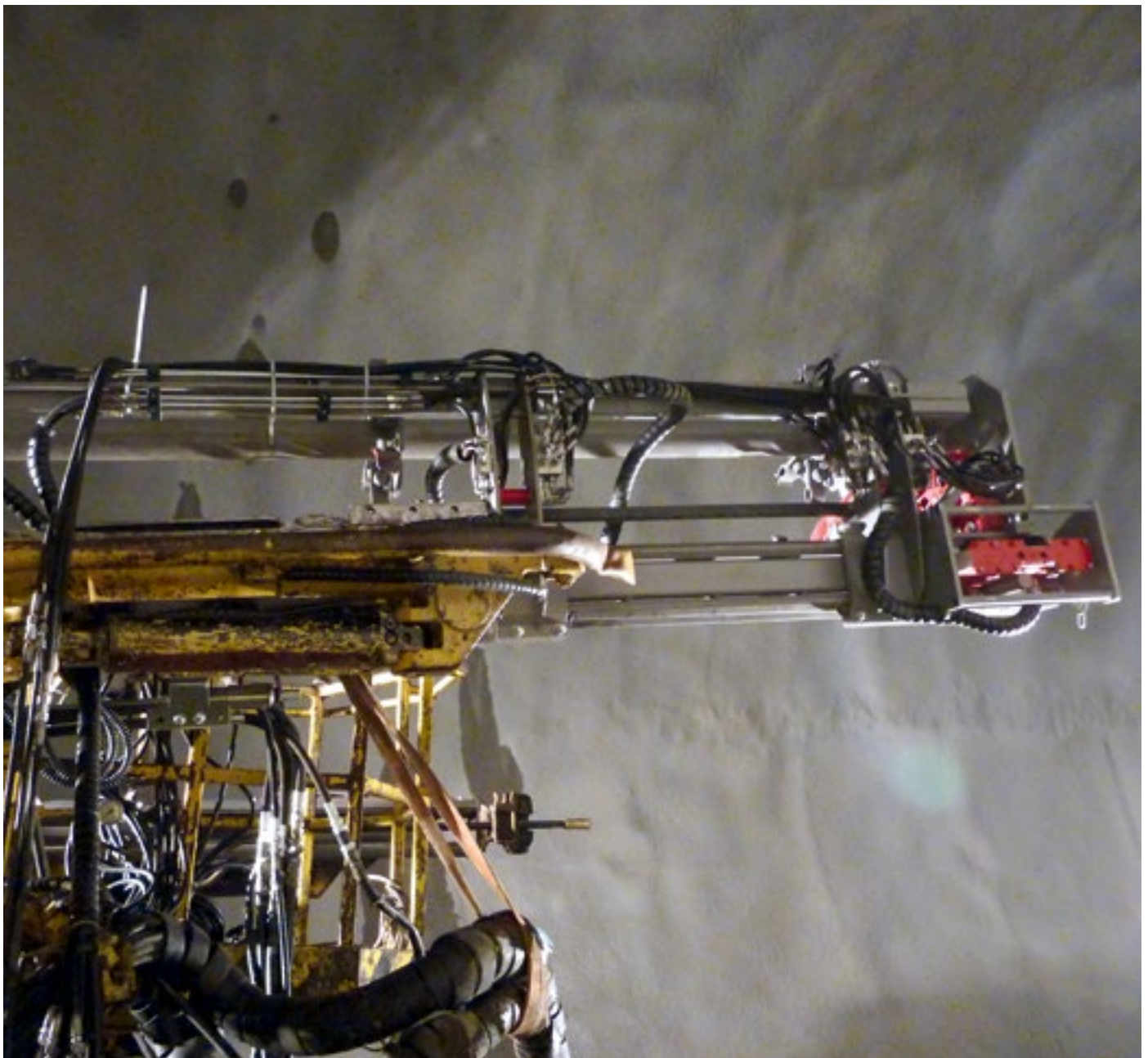

POWER SET Automation Unit

System Description

- Bolt automation for the installation of the POWER SET self-drilling friction bolt
- Independent boom unit for Underground drilling or continuous excavation machines
- Bolt drum magazine with space for up to six fully preassembled POWER SET self-drilling friction bolt units plus drill steel
- Self-drilling bolt installation and additional fixation of an expansion element (see installation procedure)
- For all standard bolt lengths up to 2.5 [m] (8.2 [ft]); special lengths available on request
- Customer-specific hydraulic rock drills
- ATEX conform version available on request



Assembly

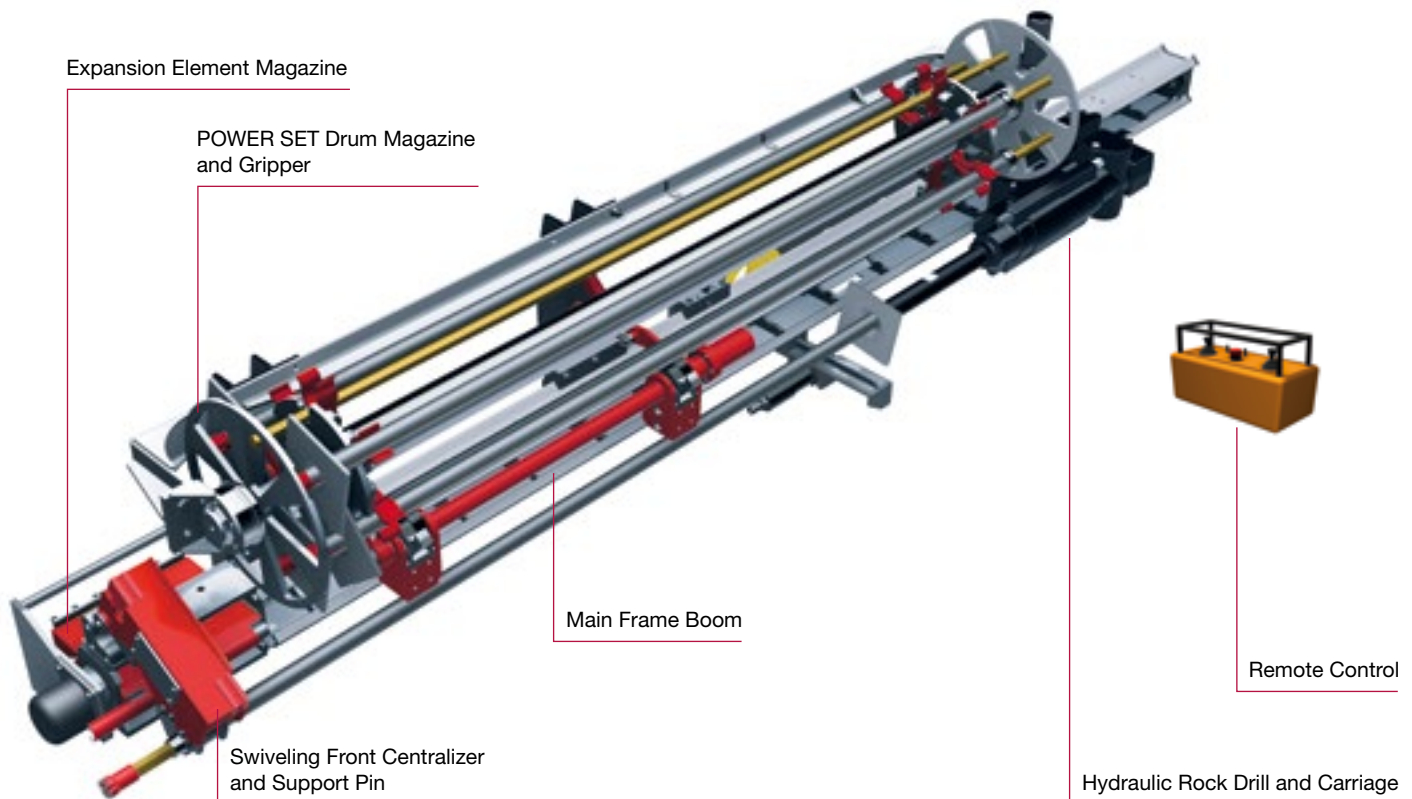

POWER SET Automation Unit

Specifications

Characteristics	Unit	Value	Remarks
Dimensions	[m]	Approx. 1 x 1 x 5	W x H x L
	[ft]	Approx. 3.3 x 3.3 x 16.4	
Weight	[kg]	Approx. 1,500	Without bolts
	[lb]	Approx. 3,300	
Hydraulic supply requirements	[L/min]	20	At approx. 170 [bar]
	[gal/min]	5.3	At approx. 2,470 [psi]
Electric supply requirements	[V]	24	DC



Further References

- Assembly instructions
- Operation and service manual, hydraulic and electric plans
- Spare parts list
- POWER SET self-drilling friction bolt user manual

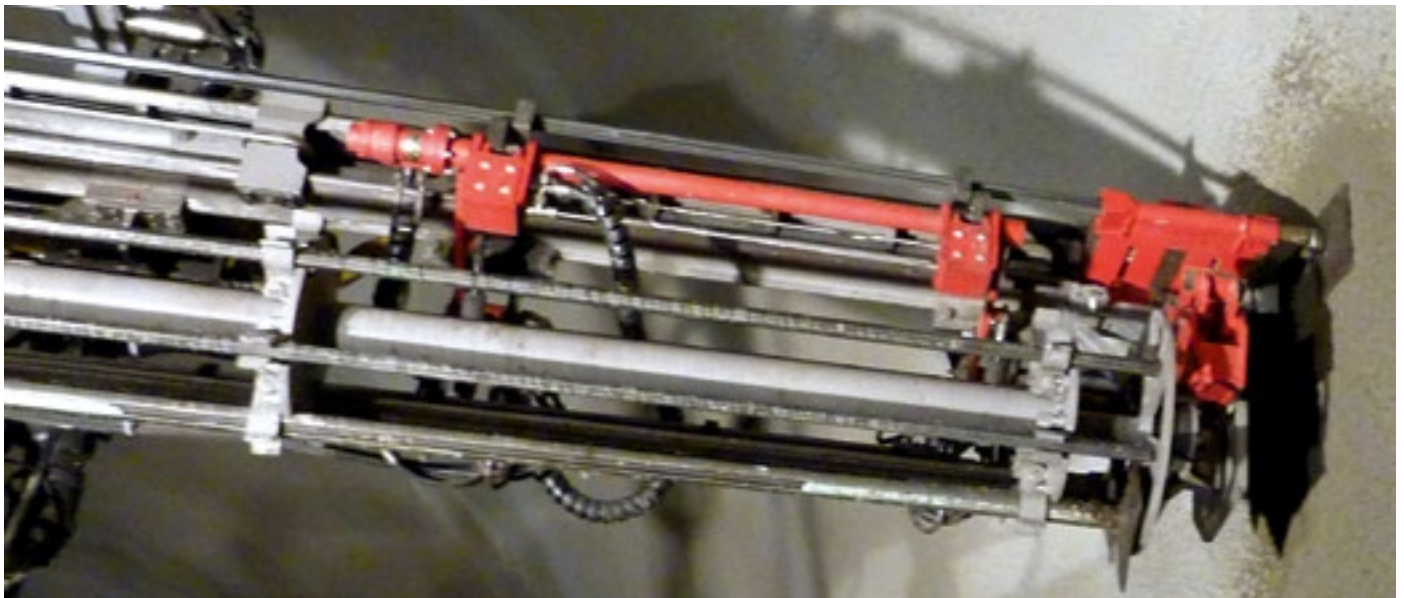

Friction Stabilizers

Introduction

Friction stabilizers are mainly used for rock reinforcement in Underground Mining. The shaft of the friction stabilizer consists of a metal strip which is folded to form a slotted tube. The bolt is installed into a borehole by applying impact energy. The borehole features a slightly smaller diameter than the outer diameter of the bolt tube.

The principle of this bolting system is based on the bond between the borehole and the tubular bolt shaft, caused by applying a force onto the borehole wall, which generates a frictional resistance in axial direction.

Recently, a self-drilling friction bolt system, the POWER SET self-drilling friction bolt, has been developed by DSI Underground in addition to conventional friction stabilizers.



Main Advantages

- Easy and fast installation procedure
- Both hand-held and fully automated installation is possible
- Immediate load-bearing capacity after installation
- Low sensitivity to ground displacements

Technical Features

- Deviations in actual borehole diameters affect the load-bearing capacity of friction stabilizers
- The actual load-bearing capacity is determined by the existing ground conditions
- Required borehole diameters must be adapted when installing in soft or highly jointed rock mass

System Components

- Friction stabilizer tube
 - Slotted steel tube
 - Tapered on the far end
 - Welded-on collar ring
- Plate
 - Default domed version
 - Different designs and dimensions available on request
- Galvanized or coated system components available on request



Friction Stabilizers

Specifications SI Units

Characteristics / Type ¹⁾	Symbol	Unit	FS33	FS39	FS46
External diameter ²⁾	D _e	[mm]	33	39	46
Nominal weight ²⁾	m	[kg/m]	1.5	1.8	2.9
Ultimate load ²⁾	F _m	[kN]	105	110	150
Yield strength ³⁾	R _e	[N/mm ²]	410	410	410
Ultimate strength ³⁾	R _m	[N/mm ²]	520	520	520
Elongation ³⁾	A	[%]	10	10	10
Recommended drill bit diameter	B	[mm]	30 - 32	36 - 38	41 - 44
Delivery lengths ⁴⁾	L	[mm]	600 - 4,000		

Specifications US Customary Units

Characteristics / Type ¹⁾	Symbol	Unit	FS33	FS39	FS46
External diameter ²⁾	D _e	[in]	1.3	1.5	1.8
Nominal weight ²⁾	m	[lb/ft]	1.0	1.2	1.9
Ultimate load ²⁾	F _m	[kip]	24	25	34
Yield strength ³⁾	R _e	[ksi]	59	59	59
Ultimate strength ³⁾	R _m	[ksi]	75	75	75
Elongation ³⁾	A	[%]	10	10	10
Recommended drill bit diameter	B	[in]	1.2 - 1.3	1.4 - 1.5	1.6 - 1.7
Delivery lengths ⁴⁾	L	[in]	24 - 158		

1) Status: 2016-04, note: all values are subject to change; other dimensions, steel grades, and compliant bolt plates available on request

2) Nominal value

3) According to primary material supplier information; modulus of elasticity: 210,000 [N/mm²] (30,450 [ksi])

4) Off-size lengths are available on request

Installation Procedure

- Drilling of a borehole according to specifications; borehole lengths should exceed the friction stabilizer length by approx. 150 [mm] (6 [in])
- Insertion of the friction stabilizer plus bolt plate onto the driver tool
- Launch of the friction stabilizer into the borehole, either manually or mechanized
- Installation into the borehole using percussion from the rock drill via a driving tool onto the collar of the friction stabilizer until the plate is firmly pressed against the excavation surface
- Note: friction stabilizers should be installed as perpendicularly as possible to the excavation surface



Installation Accessories

- Straps or mesh
- Driver tools for hand-held and mechanized bolters



Cable Bolts

Introduction

- Ground control for different fields of application
- Bolting in limited space conditions
- Reinforcement of roadways and gateways
- Bolting in the hanging wall of longwall t-junctions

Main Advantages

- Long cable bolts are easily displaceable in limited space
- High load-bearing capacity at a low weight per meter
- Flexible bolt lengths
- Installation using cement cartridges, resin cartridges, cement grout, or injection resin
- Different types of cable tensioners available on request (see section cable tensioners)

System Description

Cable bolts are available in three different versions

- Passive cable bolt, plain version
- Passive cable bolt, with bulbs
- Tensionable cable bolt

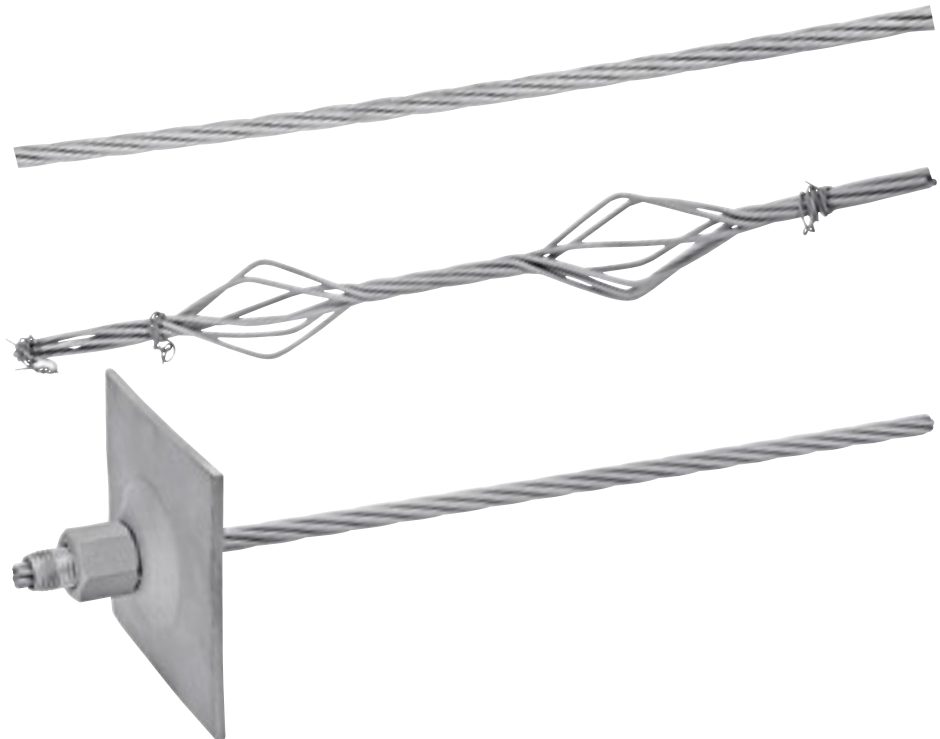

Cable Bolts

System Components

- End holding devices
 - Single strand fish hook
- 7 wire prestressing strand
 - Uncoated, low relaxation strand
 - 1 center wire and 6 outer wires
 - Plain or bulbed version
 - Different customer-specific lengths
 - Greased strands with free lengths available on request
- Plate
 - Different designs and dimensions available on request
- Domed cable grip
 - Domed barrel
 - 3 pcs. wedge
 - Optional plastic cap
- Tensionable cable bolt
 - Press sleeve
 - Metric, UNC, or DYWI® Drill thread
 - Tension nut
- Injection and breather tubes
 - Standard versions 13 x 2 [mm] (0.5 x 0.08 [in]) and 16 x 2 [mm] (0.6 x 0.08 [in])
 - Alternative designs and dimensions available on request



Specifications SI Units (Europe)

Characteristics / Type	Unit	CB15.3		CB15.7	
Nominal diameter	[mm]	15.3		15.7	
Cross-section	[mm ²]	140		150	
Weight	[kg/m]	1.09		1.17	
Yield strength R _{p0.1}	[N/mm ²]	1,560	1,680	1,560	1,680
Tensile strength	[N/mm ²]	1,770	1,860	1,770	1,860
Yield load F _{p0.1}	[kN]	218	229	243	246
Ultimate load	[kN]	248	260	266	279

Specifications US Customary Units (North America)

Characteristics / Type ¹⁾	Unit	0.6" ²⁾
Nominal diameter	[in]	0.600
Cross-section	[in ²]	0.217
Weight	[lb/ft]	0.74
Tensile strength	[ksi]	270
Yield load F _{p0.1}	[lb]	52,740
Ultimate load	[lb]	58,600
Elongation ³⁾	[%]	≥ 3.5

1) According to ASTM A416

2) 0.5", 0.7", and galvanized version available on request

3) Measuring length: 24 [in]



Cable Bolts

Installation Procedure

- Borehole drilling
- The choice of the borehole diameter depends on the drilling machinery, the cable bolt length, and the bonding medium
- Version A: filling of the borehole with cement grout or resin cartridges, then insertion of the cable bolt
- Version B: insertion of the cable bolt with factory-installed injection hose, subsequent injection with cement grout or injection resin
- Anchorage of the head: plate and wedge or press sleeve
- Prestressing of the barrel and wedge assembly with a cable bolt tensioner

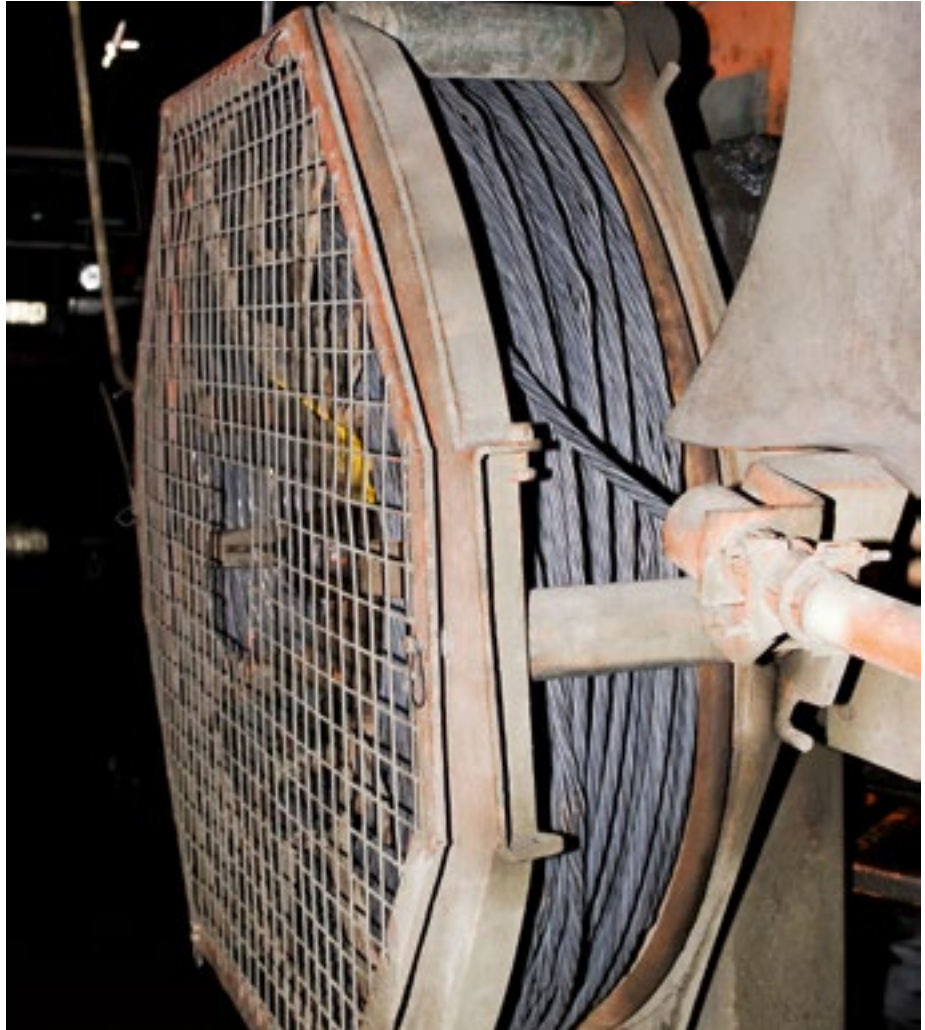

Accessories

- End holding devices
- Spin nut versions for tensioning
- Injection and breather tubes
- DYWI® Inject Systems
- Cable bolt tensioning jack
- Cable bolt expansion shell
- Dog bone coupling for slings or trusses
- Galvanized system components available on request
- Packers and borehole sealings available on request



Cable Bolt Tensioners

Introduction

Cable bolt tensioners are used for prestressing or active pre-tensioning of cable bolts. These devices for use in Underground operations are characterized by low weight, robust construction, and user-friendliness.

DSI Underground provides different systems of cable bolts, depending on individual applications.

Specifications

Characteristic Value / Type	Unit	CBT-125	CBT-300	TEN-22
Tension force	[kN]	125	320	215
	[kip]	28	72	48
Weight	[kg]	10	16	12
	[lb]	22	35	26

Fields of Application

- Pre-tensioning of type 0.6", CB15.3, and CB15.7 cable bolts
- Prestressing of cable bolts with free length
- When tensioning or pre-tensioning, the forces that are permitted for the cable bolts in use must be observed

System Components Type CBT-300

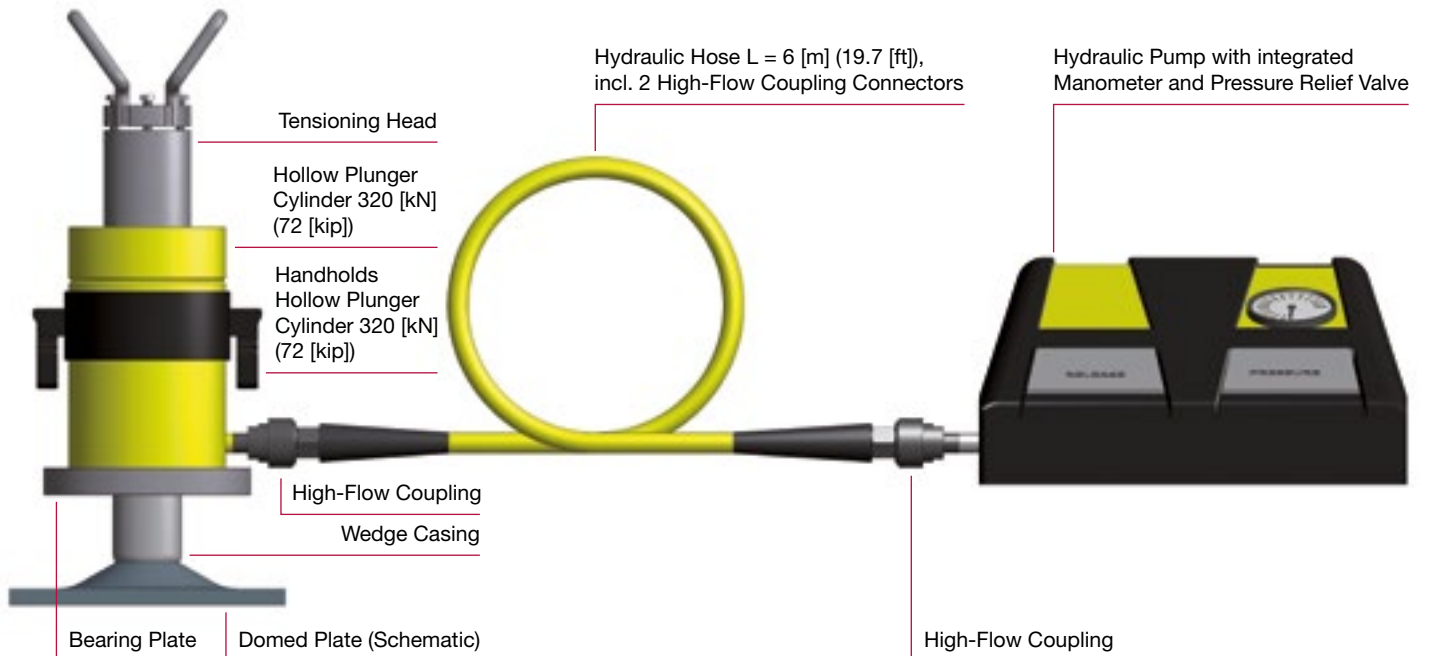

System Components Type CBT-125



GRP Bolts

Introduction

Glass-reinforced plastic (GRP) bolts are used as an alternative to conventional ground control elements made of steel. Thanks to the rapid development of production technologies and a higher amount of mechanical excavation, GRP systems have gained importance in Tunneling around the world.

Fields of application of GRP bolts range from cuttable bolts for mechanical excavations to injection lances or forepoling.

DSI Underground provides a diversified portfolio of GRP systems for various Underground applications which is completed by longtime experience in the production and application of GRP bolts.

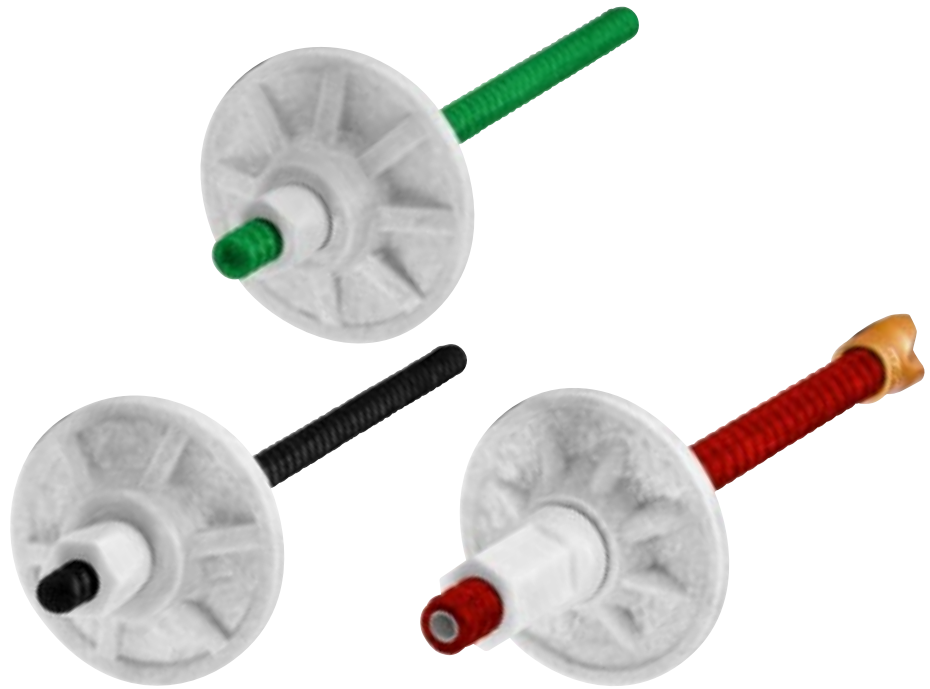

Main Advantages

- Lightweight system ensures an easy handling and installation
- High tensile load-bearing capacity
- Tough and durable, yet easy to cut using mechanical excavators or shearers
- Enhanced corrosion resistance
- Anti-static components – EX-proof system
- Tough and resistant threadform adjusted to the demands in the construction industry



GRP Bolts

System Description

- Composite system consisting of high-strength glass fibers and high performance resin
- German approval for Underground application
- Available in different versions
 - Type CS: fully threaded solid bars
 - Type CH: fully threaded hollow bars
 - Type CR: fully threaded self-drilling hollow bars with advanced, resistant composite structure
 - Reinforcing bars and composite mesh
- Installation in combination with concrete, cement grout, anchor mortar, or resin, depending on the application

System Components

- Type CS
 - Fully threaded solid GRP bar
 - GRP plate
 - GRP nut
- Type CH
 - Fully threaded hollow bar
 - GRP plate
 - GRP nut
- Type CR
 - Single-use drill bit – different designs and dimensions available
 - Fully threaded self-drilling hollow bar
 - GRP plate
 - GRP nut

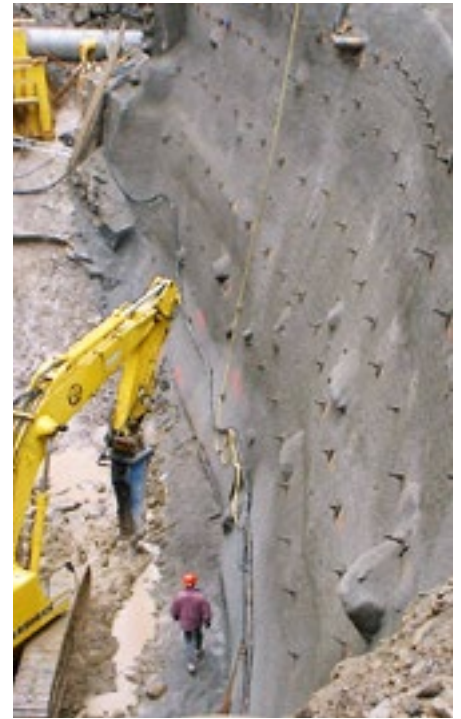

GRP Bolts

Specifications SI Units

Characteristic Value / Type ^{1) 2)}	Symbol	Unit	CS20-190	CS25-300	CS32-560	CH25-250	CH32-350	CR32-315	
Nominal external diameter	D _{e.nom}	[mm]	20	25	32	25	32	32	
Nominal cross-section ³⁾	S ₀	[mm ²]	186	346	580	230	340	340	
Nominal weight ³⁾	m	[kg/m]	0.60	0.90	1.30	0.65	1.00	0.95	
Ultimate load bar ⁴⁾	F _{m.nom}	[kN]	190	300	560	250	350	315	
Ultimate strength bar	R _{m.nom}	[N/mm ²]	1,000	900	1,000	1,000	1,000	900	
Ultimate elongation bar	A	[%]	2.5	1.7	2.5	2.5	2.5	1.5	
Shear force bar	F _{S.nom}	[kN]	90	160	230	110	140	140	
Modulus of elasticity	E	[N/mm ²]	40,000	51,000	40,000	40,000	40,000	61,000	
Ultimate load system	Steel hex nut	-	[kN]	70	170	130	100	130	140
	GRP domed nut	-	[kN]	70	70	90	70	90	105
	GRP hex nut	-	[kN]	70	170	120	100	120	200
	Steel coupling	-	[kN]	80	165	180	170	180	185
Delivery lengths ⁵⁾	L	[m]	1.0 - 6.0						
Color code	-	[-]	BLACK	BLACK	BLACK	GREEN	GREEN	RED	

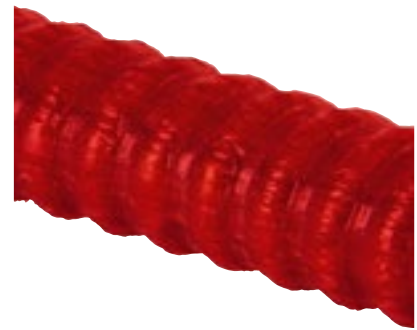

Specifications US Customary Units (alternative types available in North America on request)

Characteristic Value / Type ^{1) 2)}	Symbol	Unit	CS20-190	CS25-300	CS32-560	CH25-250	CH32-350	CR32-315	
Nominal external diameter	D _{e.nom}	[in]	0.79	0.98	1.25	0.98	1.25	1.25	
Nominal cross-section ³⁾	S ₀	[in ²]	0.29	0.54	0.90	0.36	0.53	0.53	
Nominal weight ³⁾	m	[lb/ft]	0.4	0.6	0.9	0.4	0.7	0.6	
Ultimate load bar ⁴⁾	F _{m.nom}	[kip]	43	67	126	56	79	71	
Ultimate strength bar	R _{m.nom}	[ksi]	145	131	145	145	145	131	
Ultimate elongation bar	A	[%]	2.5	1.7	2.5	2.5	2.5	1.5	
Shear force bar	F _{S.nom}	[kip]	20	36	52	25	31	31	
Modulus of elasticity	E	[ksij]	5,800	7,400	5,800	5,800	5,800	8,850	
Ultimate load system	Steel hex nut	-	[kip]	16	38	29	22	29	31
	GRP domed nut	-	[kip]	16	16	20	16	20	24
	GRP hex nut	-	[kip]	16	38	27	22	27	45
	Steel coupling	-	[kip]	18	37	40	38	40	42
Delivery lengths ⁵⁾	L	[ft]	20 - 39						
Color code	-	[-]	BLACK	BLACK	BLACK	GREEN	GREEN	RED	

1) Status: 2016-04, note: all values are subject to change; other designs and dimensions available on request; corresponding plates according to manufacturer specifications

2) According to manufacturer specifications or German approval for Underground application

3) Characteristic fractile value

4) Calculated from the characteristic ultimate strength value and nominal weight, rounded

5) Standard lengths max. 6 [m] (19.7 [ft]), customized lengths up to 11 [m] (36.1 [ft]) available on request

GRP Bolts

Technical Features

Drill Bits

- A successful installation depends on the selection of the proper drill bit
- Comprehensive drill bit portfolio for various ground conditions
- Optimized in terms of cuttability and drilling performance
- Adapted to the requirements of Underground applications
- Further information on the characteristics and selection of drill bits is available in the section DYWI® Drill



Accessories

- Steel accessories available on request
- GRP rebars
 - Fully threaded solid GRP bar
 - Threading according to the demands for concrete reinforcing elements
 - Connectors depending on the application
 - Reinforcing cages available on request
- GRP composite mesh
 - Bolt mesh and rockfall nets available on request

In-Situ Pull Testing (DIN 21521-2): Load-Displacement Diagram CR32-315 with DYWI® Inject SILO 8044-M

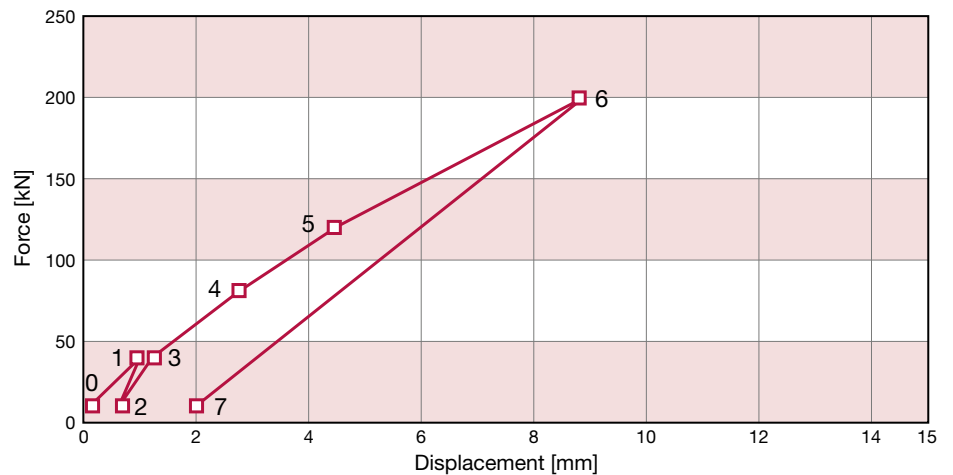

Accessories

- Plates
- Load/torque indicators
- Rock drilling equipment
- Bolt straps
- Pull testing equipment
- Mesh
- Scaling bars
- Utility hangers and nuts
- Spacers
- Angle compensation disks
- Protective caps
- Dollies and spanners
- Drill rod wrenches
- Cable and bar truss systems
- Grout mixing pumps and injection adaptors
- Injection flow-pressure meters



Corrosion Protection

DSI Underground offers a wide range of corrosion protection systems for bolts. Selection of the proper corrosion protection system is accomplished depending on the intended lifetime of the bolt and given corrosive environments. The most common protection methods for bolts are:

- Electrolytic galvanizing
 - Bonding of zinc to steel by an electro-chemical reaction
- Hot-dip galvanizing
 - Coating of a steel part with a layer of zinc by immersing the metal in a bath of molten zinc
- Sherardizing
 - Vapor galvanization
- Epoxy painting
 - Coating by application of a paint
- Duplex coatings
 - Combination method of hot-dip galvanization and powder coating

Furthermore, the sacrificial corrosion principle (see section DYWI® Drill) is commonly used in Civil Engineering and for Underground applications.



Accessories

Plates

- Standard versions: domed or flat plate
 - Standard dimensions are included in DSI Underground's system approvals
 - Domed plate: length and width up to 250 [mm] (9 27/32 [in]) and wall thickness up to 20 [mm] (25/32 [in])
 - Flat plate: various dimensions available on request
 - Custom-specific lug designs (dog ears) for domed plates
 - Plates can be made with round or long holes
- Steel grade
 - Europe: S235 or S355 according to EN 10025-2
 - North America: ASTM A 1011: grade 35 or higher
 - Other steel grades available on request
- Special plates
 - Light-weight butterfly plates for surface control
 - Surface control plates for friction bolts
 - Spider (shotcrete) plates for use in combination with bolts and shotcrete
 - Other plates are available on request



Torque Indicators

- Reliable indication for a correctly installed bolt
- Assembly between nut and bolt plate
- Available for different bolt types

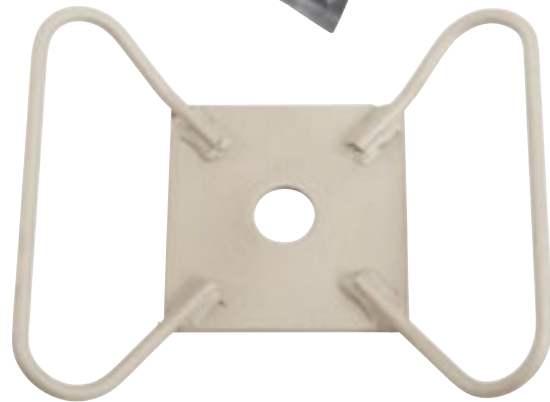

Rock Drilling Equipment

- Blasthole drilling
- Production drilling
- Extension drilling
- Overburden drilling
- Pre-drilling



System Components

- Shank adapters
- Couplings
- Adapter couplings
- Extension drilling equipment
- Coupling adapters
- Drill bits
 - Drill bits in either flat face or retrac design
 - Cross drill bits
- Pre-drilling bits for the AT-SYSTEM
- Various adapters and driver tools for bolts
- Individual drill bits available on request

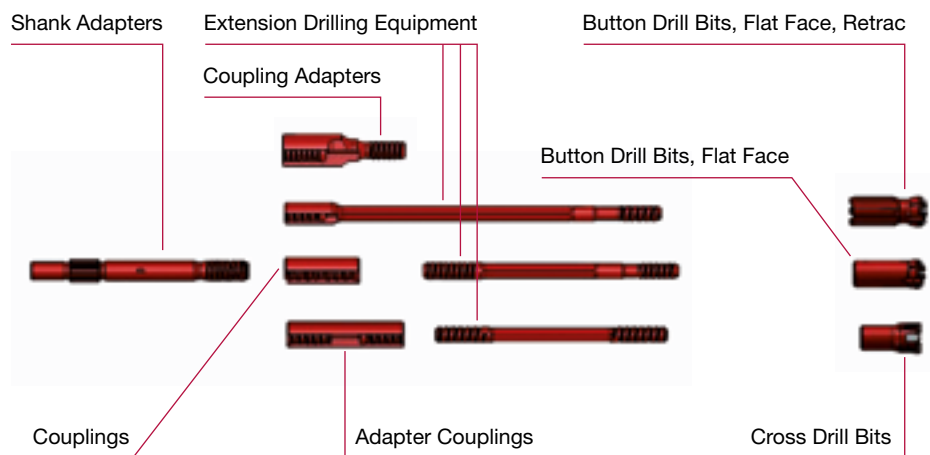

Specifications

Article Description	Available Thread Types ²⁾	Required Information ³⁾
Shank adapters	R32, R38, R51, T32, T38, T51	Thread (connecting thread type; version M or F), rock drill type, length [mm] ^{1), 3)}
Adapter couplings	R32, R38, R51, T32, T38, T51	Thread (connecting thread type)
Coupling adapters F/F ¹⁾	R32, R38, R51, T32, T38, T51	Thread (connecting thread type A and B)
Extension rods M/F ¹⁾	R32, R38, R51, T32, T38, T51	Thread (type connecting thread); length [mm] ³⁾
Extension rods M/M ¹⁾	R32, R38, R51, T32, T38, T51	Thread (type connecting thread); length [mm] ³⁾
Adapter M/F ¹⁾	R32, R38, R51, T32, T38, T51	Thread (connecting thread type A and B)
Adapter M/M ¹⁾	R32, R38, R51, T32, T38, T51	Thread (connecting thread type A and B)
Button drill bits version flat face	R32, R38, R51, T38, T51	Thread (connecting thread type), drill bit diameter
Button drill bits version retrac	R32, R38, R51, T38, T51	Thread (connecting thread type), drill bit diameter
Cross drill bits	R32, R38, R51, T38, T51	Thread (connecting thread type), drill bit diameter
Pre-drilling bits	R32, R38, R51, T38, T51	Thread (connecting thread type), drill bit diameter
Driver tools	R32, R38	Bolt type, thread (type connecting thread)

1) "F" ... female (inner) thread; "M" ... male (outer) thread

2) Special thread types available on request

3) Special lengths available on request

Mesh and Straps

OSRO Straps ¹⁾

Length		Width		Horizontal Bar Diameter		Strapping Bar Diameter	
[mm]	[in]	[mm]	[in]	[mm]	[in]	[mm]	[in]
1,000 - 6,000	39 - 236	250 - 1,000	10 - 39	6 - 10	0.25 - 0.40	5.5	0.2

W-Straps ¹⁾

Length		Width		Wall Thickness		Standard Hole Spacing	
[mm]	[in]	[mm]	[in]	[mm]	[in]	[mm]	[in]
1,000 - 3,000	39 - 118	220 - 500	9 - 20	1.5 - 6.0	0.05 - 0.25	500	20

1) Alternative dimensions available on request



Pull Testing Equipment

Introduction

Pull testing equipment is required for non-destructive and destructive pull-out tests on anchors and bolts.

Pull-out tests on anchors and bolts are performed for supervision of the bolting quality. Depending on the type and design of the bolt in use, different testing equipment is utilized.

Depending on the operation purpose, modularly designed sets of different pull testing equipment can be adapted to the whole range of bolts provided by DSI Underground.



System Components

The pull testing equipment consists of a series of mechanic and hydraulic components and is designed for an ultimate test force of up to approx. 60 [t].

- Hydraulic components
 - Hollow plunger cylinder
 - Hydraulic hose
 - Electric pump or hand pump, with manometer
 - Manometers can be provided with a calibration certificate
- Supporting frame
 - Depending on test requirements and test forces, the frame is available either as a tripod or a tubular frame in different sizes
- Mechanic components
 - Intermediate disks
 - Angle compensation plates
 - Balance rods and adapters for bolts that are to be tested

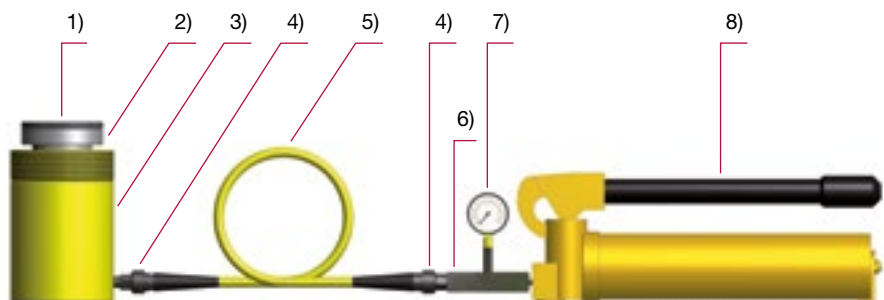

Components

- 1) Bearing plate hollow plunger cylinder/nut
- 2) Thrust piece
- 3) Hydraulic hollow plunger cylinder, single acting
- 4) High-flow coupling
- 5) Hydraulic hose incl. 2 high-flow coupling connectors
- 6) Manometer piece
- 7) Manometer (incl. calibration certificate)
- 8) Hand pump or compact electric pump



Pull Testing Equipment

Specifications

Anchor or Bolt Type	Hydraulic Cylinder ¹⁾		Tripod or Bearing Cylinder ²⁾		Pull Adapter ³⁾
	Max. 320 [kN] (72 [kip])	Max. 640 [kN] (144 [kip])			
DYWI® Drill Hollow Bar System	X	X	X	X	DYWI® Drill coupling, hollow bar, and nut
GEWI® mechanical anchor	X		X		GEWI® coupling, rod and nut
Mechanical rebar anchors	X		X		Pull adapter, washer, and nut
THREADBAR	X	X	X		GEWI® coupling, rod and nut
Rebar and resin bolts	X		X		Pull adapter, washer, and nut
DYWI® Drill combination bolts	X	X	X		DYWI® Drill coupling, hollow bar, and nut
CT-Bolt™ combination bolts	X		X		Pull adapter, washer, and nut
OMEGA-BOLT® expandable friction bolts	X		X		OMEGA-BOLT® pull head, washer, and nut
POWER SET self-drilling friction bolts	X			X	POWER SET pull testing equipment
Friction stabilizers	X		X	X	POWER SET pull testing equipment
Cable bolts	X	X	X	X	See section cable tensioners
GRP bolts	X		X	X	DYWI® Drill coupling, hollow bar, and nut

1) Proof force range 0 - 320 [kN] (0 - 72 [kip]): hollow plunger cylinder type RCH-302 / proof force range 0 - 640 [kN] (0 - 144 [kip]): hollow plunger cylinder type RCH-603

2) Tripod or bearing cylinder according to hydraulic cylinder type

3) Schematic display. Coupling, pull head, pull rod, washer and nut are adapted to each anchor and bolt type

Further References

- DSI Underground's leaflets on pull tests
- System sketch of test assemblies
- Data sheets and operating procedures
- Pull tests must only be carried out in compliance with the present instructions and by skilled personnel
- DSI Underground has experienced technical personnel for planning, operation, and analysis of pull tests







Pre-Support

Fields of Application

AT – Pipe Umbrella Support System

- Advances in weak ground and ground conditions prone to subsidence
- Advances in fault zones, sediments, or talus
- Portal sections
- Frequently changing ground conditions
- Re-excitation of collapsed drifts or tunnels
- Urban Tunneling

Cross Section when Excavating under an AT – Pipe Umbrella

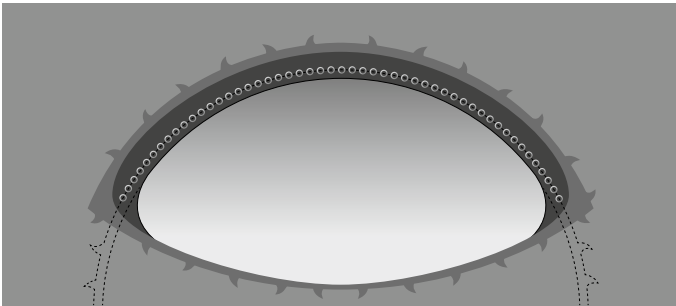

Single AT – Pipe Umbrella

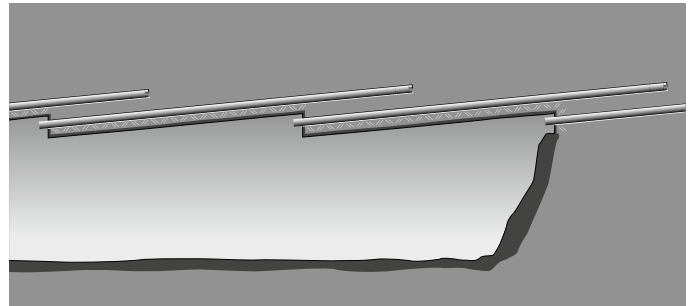

Single AT – Pipe Umbrella with Double Overlap

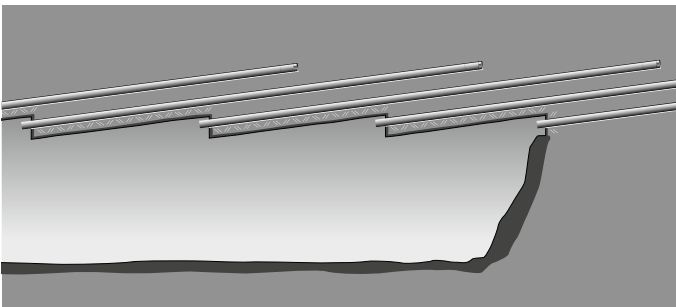

Double AT – Pipe Umbrella

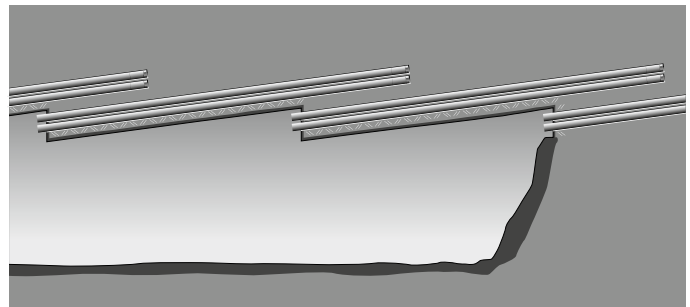

Spiles and Forepoling Boards

- AT – TUBESPILE™
 - Tunneling in soft homogeneous or inhomogeneous ground
 - Fault zones, sedimentary ground, or debris
 - Blocky rock mass
- DYWI® Drill self-drilling spiles
 - Pre-support in any ground type
 - Particularly suitable for unstable boreholes
- Rebar and tubular spiles
 - Blocky and jointed rock mass
 - Tunnel driving in soft, homogenous ground conditions
- Forepoling boards
 - Non-cohesive soil
 - Pre-support in nearly non-cohesive soil

Cross-Section

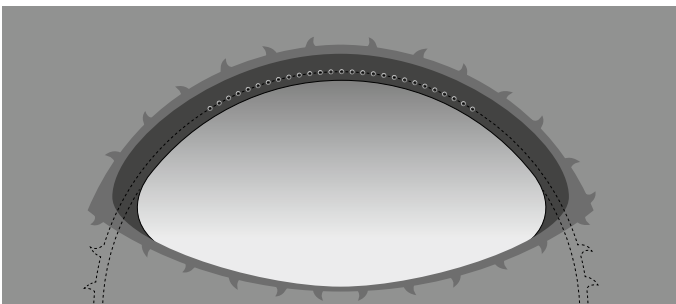

Spile Support

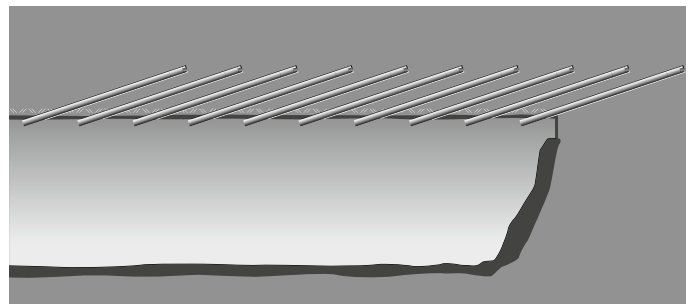

Contents

AT – Pipe Umbrella Support System	146
Self-Drilling Installation Technology	148
AT – Pipe Couplings	150
AT – Pipe Umbrella Automation Unit	153
Accessories	157
AT – TUBESPILE™	158
DYWI® Drill Self-Drilling Spiles	160
Tubular Spiles and Rebar Spiles	162
Forepoling Boards	164



AT – Pipe Umbrella Support System

Introduction

The AT – Pipe Umbrella System is a pre-support measure used in weak ground conditions in conventional as well as mechanized Tunneling. Pipe umbrella pipes increase the stability in the working area by transferring loads in the longitudinal direction and decrease excavation induced deformations. The system increases safety in the working area. Besides this standard usage, the system is often applied to increase stability in portal sections and for the re-excavation of collapsed sections in Underground environments. Another application area is ground improvement and waterproofing in combination with all tunnel construction methods.

Main Advantages

- Installation with conventional drill jumbos
- Implementation of pipe umbrella drilling with on-site personnel
- Simple and robust system components
- Fast self-drilling installation
- Smallest possible stress relaxation due to an immediate support of the borehole wall during installation
- Accurate installation due to a minimized annular gap
- Length of pipe umbrella pipes can be adapted to confined space
- Different pipe coupling types are available to suit different project requirements

System Description

The AT – Pipe Umbrella System is installed as follows:

- Using the overburden drilling method
- Piecewise
- With conventional drill jumbos
- By hydraulic, rotary-percussive drilling

Cooling, flushing, and backflow of the cuttings takes place inside the casing pipes by using water.

System Components

- AT – Starter Unit with drill bit
- AT – Extension Tubes
- Injection valves
- Various AT – Adapters
- Drill rods
- AT – Grouting Plug (end plug)



AT – Pipe Umbrella Support System

Specifications SI Units

System ¹⁾	Steel Grade ²⁾	Modulus of Elasticity	Yield Strength	Outer Diameter	Wall Thickness	Weight	Moment of Inertia	Section Modulus	Maximum Moment (Elastic)
Type		[N/mm ²]	[N/mm ²]	[mm]	[mm]	[kg/m]	[cm ⁴]	[cm ³]	[kN·m]
AT – 76	S355 or E355	210,000	355	76.1	6.3	10.8	85	22	7.9
AT – 89				88.9	6.3	12.8	140	31	11.2
AT – 114				114.3	6.3	16.8	313	54	19.4
AT – 139				139.7	6.3	20.7	589	84	29.9
				139.7	8.0	26.0	720	103	36.6
AT – 168				168.0	12.5	47.9	1,858	221	78.5

Specifications US Customary Units

System ¹⁾	Steel Grade	Modulus of Elasticity	Yield Strength	Outer Diameter	Wall Thickness	Weight	Moment of Inertia	Section Modulus	Maximum Moment (Elastic)
Type		[ksi]	[ksi]	[in]	[in]	[lb/ft]	[in ⁴]	[in ³]	[lb·ft]
AT – 76	3)	30,500	≥ 51.5	3.0	0.25	7.3	2.04	1.34	5,830
AT – 89				3.5	0.25	8.6	3.36	1.89	8,260
AT – 114				4.5	0.25	11.3	7.52	3.30	14,310
AT – 139				5.5	0.25	13.9	14.15	5.13	22,050
				5.5	0.31	17.5	17.30	6.29	27,000
AT – 168				6.6	0.49	32.2	44.64	13.49	57,900

1) Deviating structural properties are available on request

2) Steel grade S355 according to EN 10025-2 or E355 according to EN 10296-1. Alternatively, a carbon steel with a minimum yield strength of 355 [N/mm²] is required

3) Reference steel grade: carbon steel with a minimum yield strength of 51.5 [ksi]



Self-Drilling Installation Technology

Technical Features

- Quick length adjustment of the AT – Pipe Umbrella System facilitated by piecewise installation
- Simple connection of extension tubes even in restricted space
- High drilling accuracy of pipe umbrella drills
- Special pipe coupling types for different project requirements
- The use of the AT – Pipe Umbrella Automation Unit increases the installation progress, minimizes over-excavation (saw tooth profile), and increases personnel safety
- Application of preventers possible
- Recording and control of the grouting process using an injection flow-pressure meter

AT – Drilling System

The drilling energy is transferred via drill rods and an inside adapter onto the single-use drill bit of the AT – Starter Unit. The cooling and flushing medium is immediately transported from the drill bit front backward inside the umbrella pipes. After completion of the installation, the single-use drill bit remains at the toe of the borehole; adapter and drill rods are removed and re-used for consecutive pipe installations.

- Loss or blocking of a drill bit is impossible because it is fixed within the starter unit
- A single-use drill bit ensures the same high quality for each drilling process
- Application of a single-use drill bit provides optimum pre-conditions for achieving the total drilling depth every time
- The drill bit type can be adapted to given geological conditions
- Stable drilling direction due to stable drill bit orientation
- Disconnecting and reconnecting of drill rods is possible at any time
- Small overcutting ensures the lowest possible stress relaxation





1. For drilling, the AT – Starter Unit with drill bit is assembled together with the first AT – Extension Tube, the AT – Adapter, and the drill rod onto the drill boom.

2. Installation of the first AT – Extension Tube.



3. The next drill rod with AT – Extension Tube is connected to the previously installed pipe, and the drilling process is continued afterwards.



4. The last step is repeated until the designed length of the AT – Pipe Umbrella has been installed.

AT – Pipe Couplings

The AT – Pipe Umbrella System is installed using conventional drilling machines. Single pipes are installed piecewise at a length that fits the drill boom length.

Type and quality of the pipe coupling are decisive factors for the maximum achievable load-bearing capacity of the support system.

For this reason, three different types of couplings are available for the AT – Pipe Umbrella System.

Standard Thread Connection

When using a standard thread connection, an outside and inside thread is cut into the ends of the pipe umbrella pipes. This type of coupling reduces the cross-section of the pipe in the area of the thread connection. This way, the section modulus is decreased as well. Besides the geometrical conditions of the thread, the overall quality of the pipes is a major concern for the maximum load-bearing capacity. In general, calibrated tubes reach a higher resistance against bending than non-calibrated ones.

This connection type can be recommended for the installation of measurement instrumentations and for ground-improving injection works.

- Installed tubes show a constant inner diameter
- The stiffness and strength of the connection is considerably lower than those of standard pipes
- The rupture load of the connections is comparable to the design load of standard pipes; it is clearly lower for non-calibrated tubes
- Further decrease of the load-bearing capacity if mistakes occur during connecting or grouting of the pipes
- A lower load-bearing capacity can only be compensated by a higher number of pipes
- Dislocation of the coupling positions in the longitudinal direction does not significantly increase the load-bearing capacity
- Installation can be accomplished with or without an AT – Pipe Umbrella Automation Unit



AT – Pipe Couplings

Squeezed Connection

A squeezed connection consists of a reduced pipe end which is force-fitted with its counter piece. In the coupling area, the cross section stays constant and the section modulus is decreased. Usage of this connection type can be recommended for all advances where a pipe umbrella is installed because of its static load-bearing capacity.

- Simplest connection type
- The ultimate load of this connection is considerably higher than the elastic design load of a normal pipe (> 1.5)
- Transition from elastic to plastic material behavior begins at approximately 2/3 of the elastic design load (standard pipe)
- Reduction of the inner diameter in the connection area
- Reduction of the stiffness against bending in the connection area
- Installation is accomplished with a so-called AT – Squeezing Unit, preferably in combination with an AT – Pipe Umbrella Automation Unit

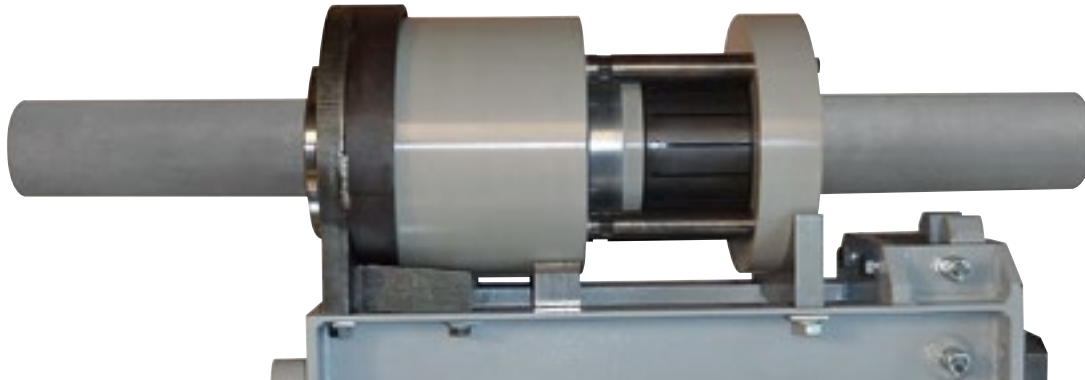

Technical Features

- Easy-to-handle AT – Squeezing Unit
 - Application in combination with default jumbos or track drills
 - Mounting onto a default boom or use in combination with an AT – Automation Unit
 - Remote control operation of the squeezing unit
- Safe and rapid tube connection
 - No “hands on” during the pipe connecting working step
 - Integrated drill rod wrench allows safe drill steel manipulation
 - Reduction of physical labor required
 - Minimization of exposure time in the excavation area
- Time and material savings
 - Faster connection process than for standard threads
 - Elimination of delays caused by jammed or damaged tubes
 - Proven total time savings
 - Optimization of pipe handling, freight charges, and material intensity



AT – Pipe Couplings

Nipple Coupling

Nipple couplings are an additional steel nipple with a thread connection that is pressed and welded into both ends of the extension tubes. This ensures that the section modulus at the coupling is never lower than the section modulus of the standard pipe.

Usage of this connection type can be recommended for advances where the static load-bearing capacity is required to achieve stable conditions and where settlement limitations are part of the design.

- The elastic design load is equal to the one of a standard pipe
- Stiffness in the elastic range is comparable to the one of a standard pipe
- Reduction of the inner cross-section
- Installation can be accomplished with or without an AT – Pipe Umbrella Automation Unit



Comparison Pipe Couplings AT – 114.3 x 6.3 [mm]

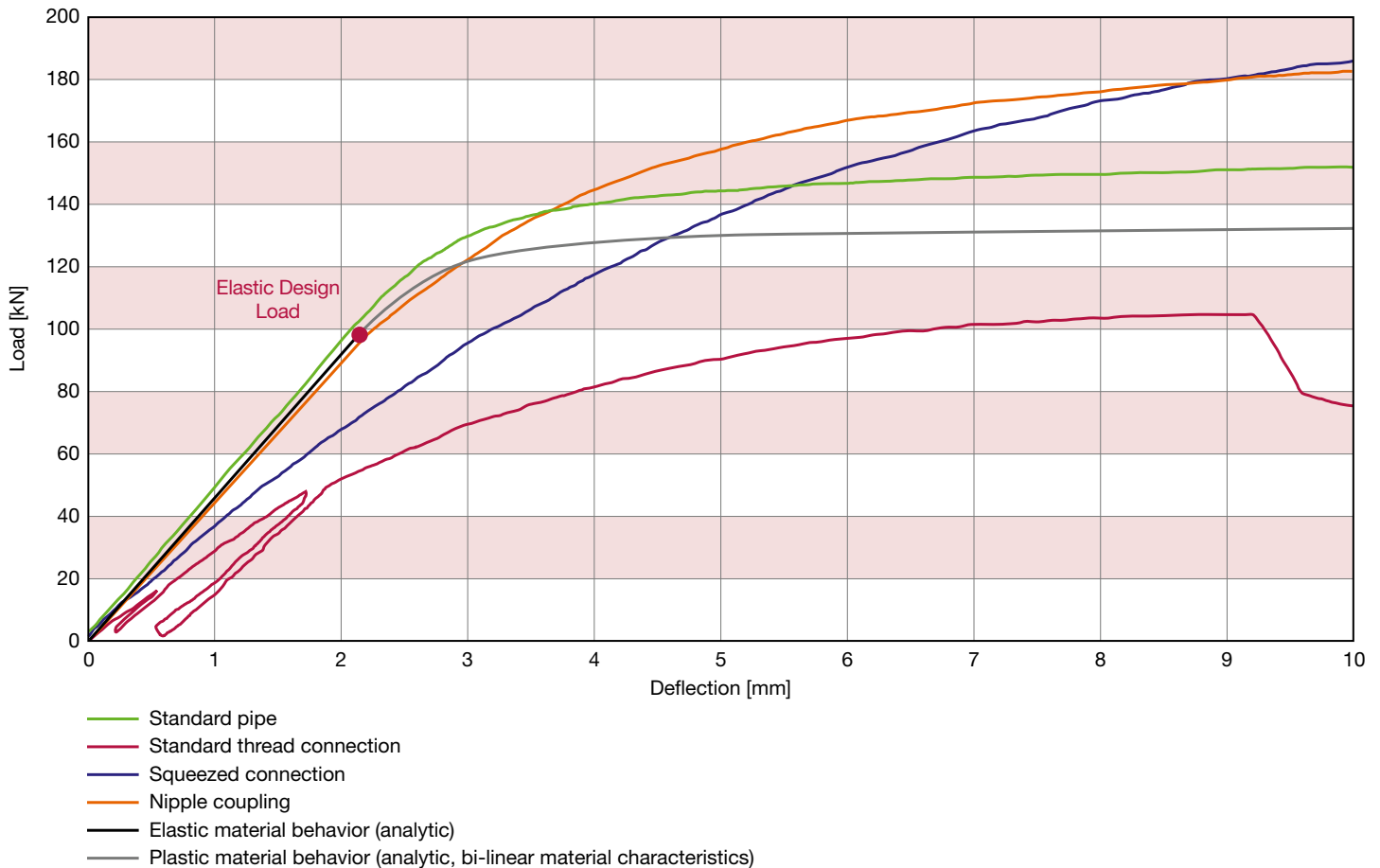

AT – Pipe Umbrella Automation Unit

The AT – Pipe Umbrella Automation Unit allows automated feeding, connecting, and installation of extension tubes plus drill rods.

Main Advantages

- Compatible with every standard drill jumbo
- Shorter manipulation times due to exact and automated feeding
- Faster construction of a pipe umbrella support system
- Higher occupational safety
- No handling in the vicinity of moving parts of the drilling machine
- Simple re-charging of extension tubes via a loading basket
- Remote-controlled feeding of tubes
- Less manpower required
- Optimum utilization of the working space
- Smaller saw-tooth shaped profile and thereby less excavation volume



AT – Pipe Umbrella Automation Unit

Assembly Groups - Squeezing Unit

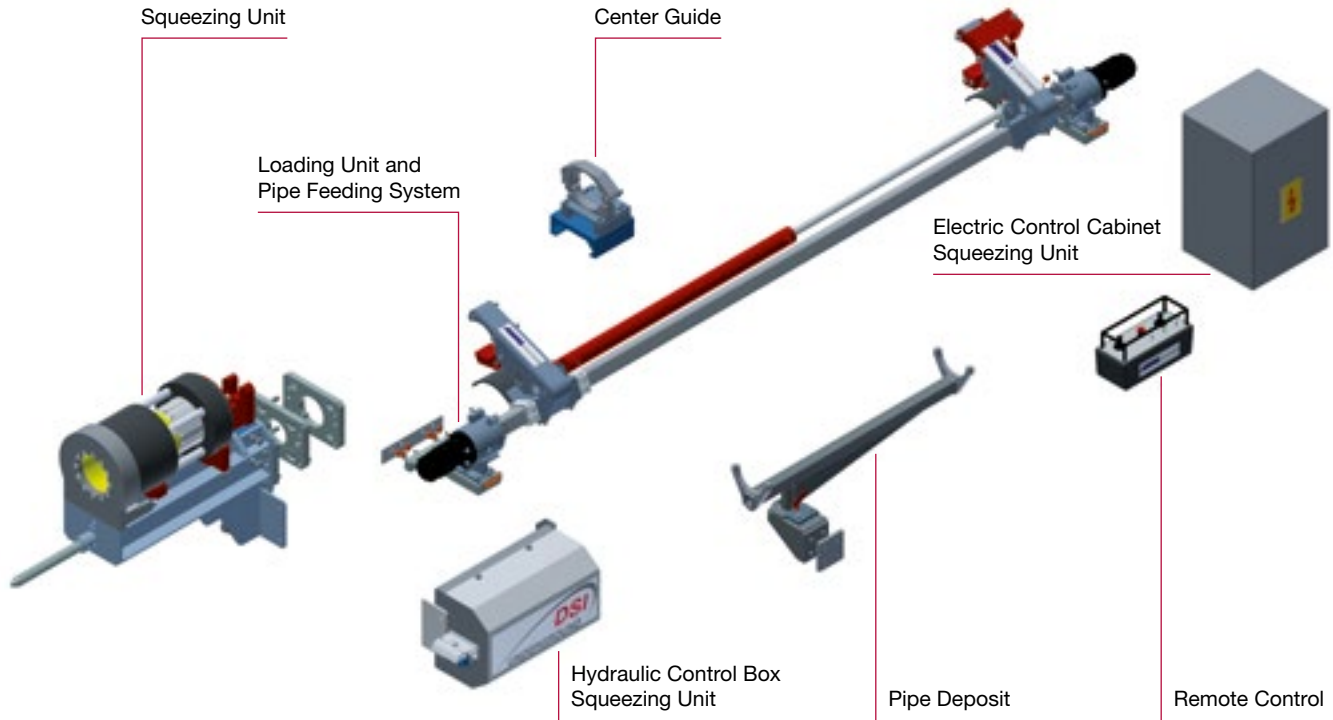

Specifications SI Units

Characteristic / Assembly Group	Dimensions (L x W x H) [mm]	Weight [kg]
Pipe deposit	1,040 x 230 x 350	28
Squeezing unit	1,165 x 380 x 750	200
Loading unit and pipe feeding system	3,650 x 460/780 x 430/570	160
Center guide	155 x 260 x 230	12
Hydraulic control box squeezing unit	550 x 275 x 345	60
Electric control cabinet squeezing unit	395 x 615 x 355	35
Remote control	250 x 140 x 180	2.3

Characteristic	Unit	Value	Remarks
Total weight (gross)	[kg]	500 - 520	Deviations possible, depending on the type
Electric supply	[V]	24	DC
Hydraulic supply	[L/min]	20 - 25	At approx. 200 [bar]

Specifications US Customary Units

Characteristic / Assembly Group	Dimensions (L x W x H) [in]	Weight [lb]
Pipe deposit	40.9 x 9.1 x 13.8	62
Squeezing unit	45.9 x 15.0 x 29.5	441
Loading unit and pipe feeding system	143.7 x 18.1/30.7 x 16.9/22.4	353
Center guide	6.1 x 10.2 x 9.1	27
Hydraulic control box squeezing unit	21.6 x 10.8 x 13.8	133
Electric control cabinet squeezing unit	15.6 x 24.2 x 14.0	77
Remote control	9.8 x 5.5 x 7.1	5

Characteristic	Unit	Value	Remarks
Total weight (gross)	[lb]	1,100 - 1,150	Deviations possible, depending on the type
Electric supply	[V]	24	DC
Hydraulic supply	[gal/min]	5.3 - 6.6	At approx. 2,900 [psi]

AT – Pipe Umbrella Automation Unit

Assembly Groups - Threading Unit

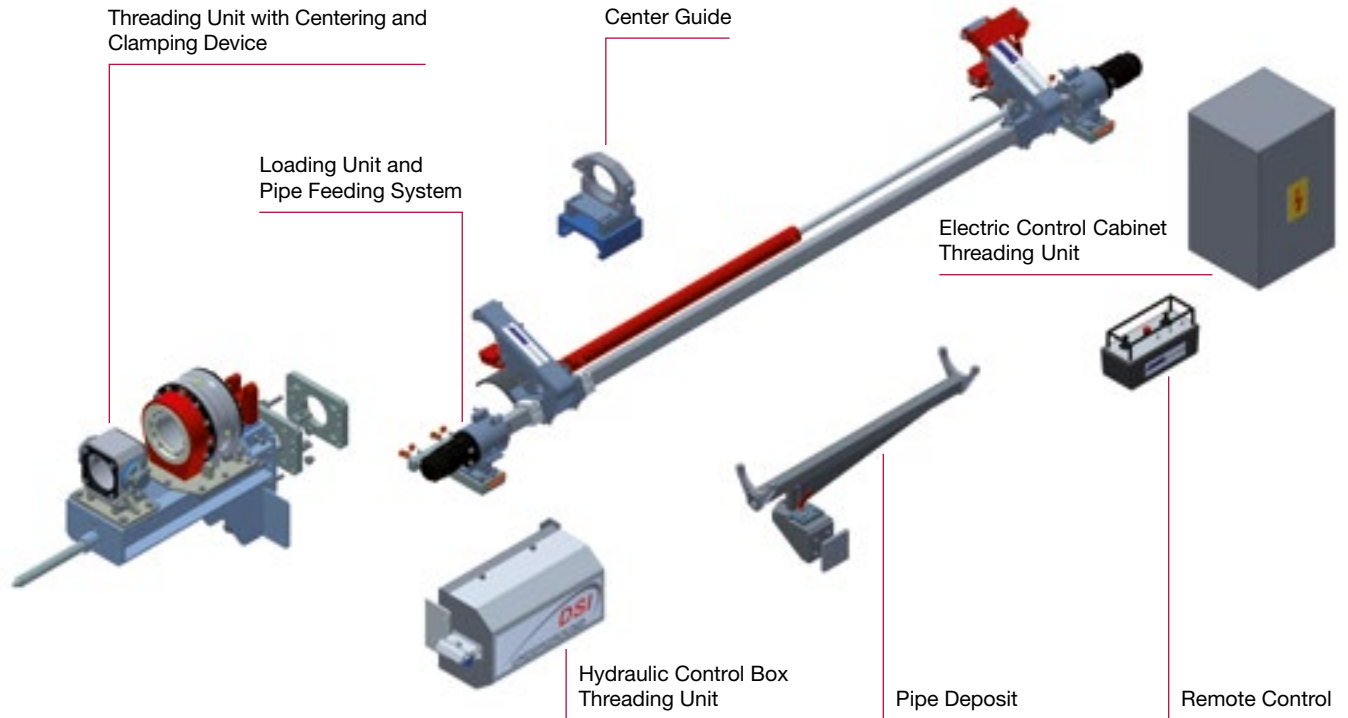

Specifications SI Units

Characteristic / Assembly Group	Dimensions (L x W x H) [mm]	Weight [kg]
Pipe deposit	1,040 x 230 x 350	28
Threading unit with centering and clamping device	1,165 x 370 x 740	160
Loading unit and pipe feeding system	3,650 x 460/780 x 430/570	160
Center guide	155 x 260 x 230	12
Hydraulic control box threading unit	550 x 275 x 345	60
Electric control cabinet threading unit	395 x 615 x 355	35
Remote control	250 x 140 x 180	2.3

Characteristic	Unit	Value	Remarks
Total weight (gross)	[kg]	460 - 490	Deviations possible, depending on the type
Electric supply	[V]	24	DC
Hydraulic supply	[L/min]	15 - 20	At approx. 170 [bar]

Specifications US Customary Units

Characteristic / Assembly Group	Dimensions (L x W x H) [in]	Weight [lb]
Pipe deposit	40.9 x 9.1 x 13.8	62
Threading unit with centering and clamping device	45.9 x 14.6 x 29.1	353
Loading unit and pipe feeding system	143.7 x 18.1/30.7 x 16.9/22.4	353
Center guide	6.1 x 10.2 x 9.1	27
Hydraulic control box threading unit	21.6 x 10.8 x 13.8	133
Electric control cabinet threading unit	15.6 x 24.2 x 14.0	77
Remote control	9.8 x 5.5 x 7.1	5

Characteristic	Unit	Value	Remarks
Total weight (gross)	[lb]	1,010 - 1,080	Deviations possible, depending on the type
Electric supply	[V]	24	DC
Hydraulic supply	[gal/min]	4.0 - 5.3	At approx. 2,500 [psi]

AT – Pipe Umbrella Automation Unit

Mounted Assembly Groups

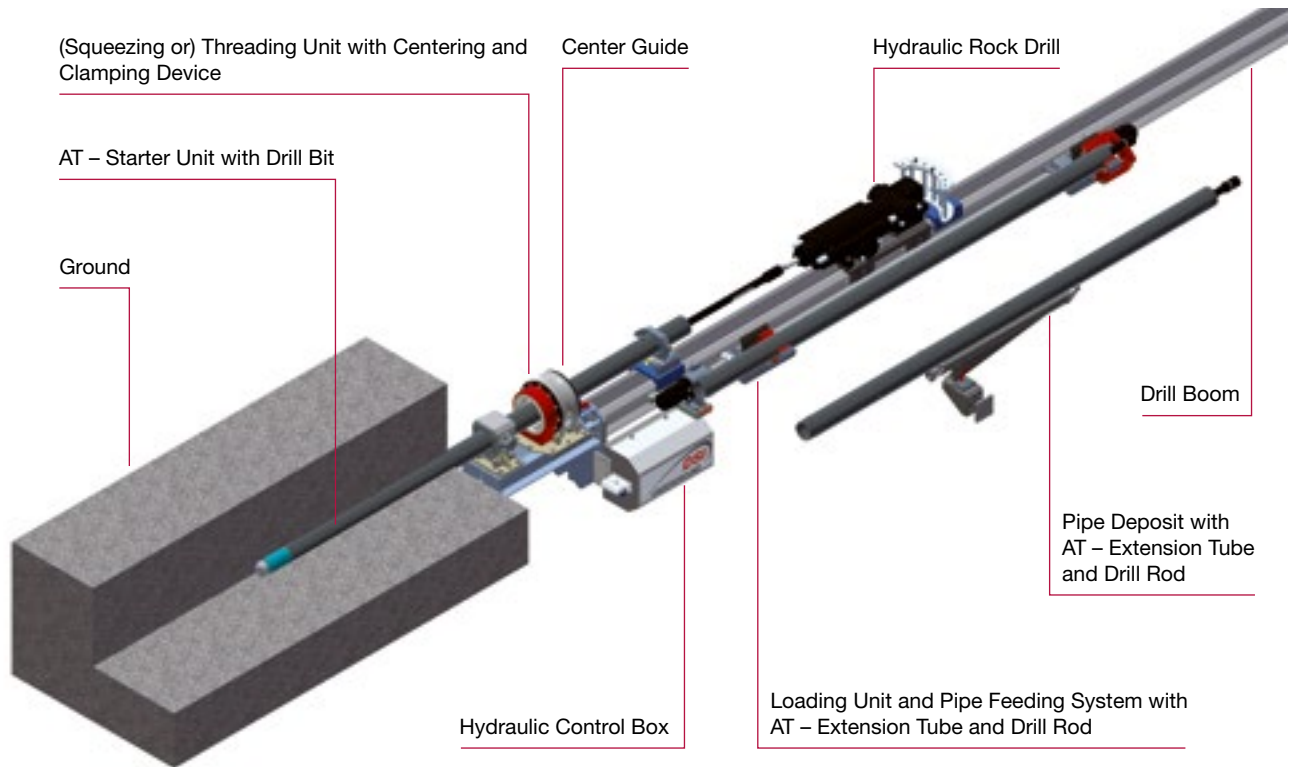

Accessories

- Injection flow-pressure meter
- Injection packer
- Grout mixing pump
- DYWI® Inject Systems
- Fishing tab
- Drill rod wrench
- Chain pipe wrench
- Rock drilling equipment: shank adapter, coupling, and coupling adapter



Further References

- Volkmann, G.M. & W. Schubert 2007. "Geotechnical Model for Pipe Roof Supports in Tunneling." In Proc. of the 33rd ITA-AITES World Tunneling Congress, Underground Space. The 4th Dimension of Metropolises, Volume 1. eds. J. Bartak, I. Hrdina, G. Romancov, J. Zlamal, Prague, Czech Republic, 5-10 May 2007, Taylor & Francis Group, ISBN: 978-0-415-40802. app. 755-760
- Volkmann G.M. & Schubert W. 2008. Tender Document Specifications for Pipe Umbrella Installation Methods. In proceedings of the 34th ITA-AITES World Tunneling Congress, Agra, India, 22-24 September 2008, pp. 285-293
- G.M. Volkmann, 2014. „Development of State-of-the-Art Connection Types for Pipe Umbrella Support Systems“, 15th Australasian Tunneling Conference 2014 / Sydney, NSW, 17-19 September 2014
- AT – Pipe Umbrella geometry calculator
- Installation manual AT – Pipe Umbrella System



AT – TUBESPILE™

Introduction

The AT – TUBESPILE™ forms part of the POWER SET product family. It qualifies perfectly as a pre-support system in conventional Tunneling and is classified as a spile.

The application of the AT – TUBESPILE™ permits the stabilization of local instabilities in the excavation area and the prevention of ground loosening induced by installation. In poor ground conditions, this system is a sound alternative to conventional ram spiles, rebar spiles, or DYWI® Drill self-drilling spiles.

Main Advantages

- Installation using conventional drill jumbos
- Secure and easy installation procedure
- Spile drilling and installation in one step
- Ground-preserving, self-drilling installation
- Higher section modulus than comparable rebar spiles

System Description

The AT – TUBESPILE™ is installed in one step through rotary percussive drilling with conventional drill booms. The drill rod inside the spile tube transfers the drilling energy onto the drill bit, which is available as a button drill bit with carbide inserts and as a hardened arc-shaped drill bit. The AT – TUBESPILE™ is pushed into the borehole by an adapter and follows directly behind the drill bit. Cooling, flushing, and transport of cuttings take place inside the spile tube with water.

System Components

- AT – TUBESPILE™ drill bit
 - Single-use drill bit Ø 52 [mm] (Ø 2 3/64 [in]), arc-shaped or button bit version available
- AT – TUBESPILE™
 - Spile tube Ø 51 [mm] (Ø 2 [in])
- POWER SET drill rod
 - Special drill steel for optimum service life
- POWER SET adapter
 - Controlled transfer of the impact energy onto the AT – TUBESPILE™

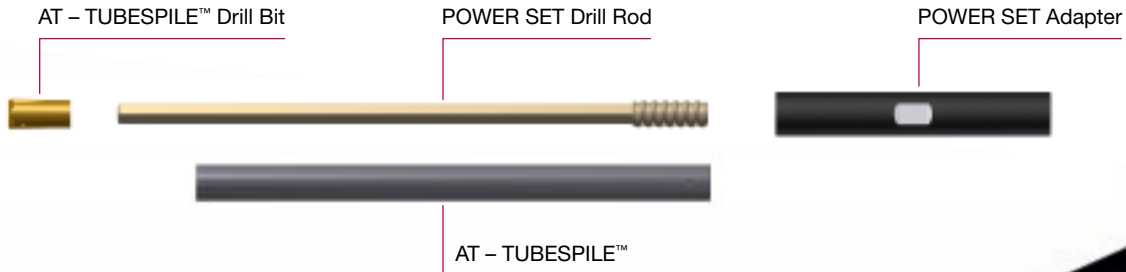

Ready-For-Use AT – TUBESPILE™

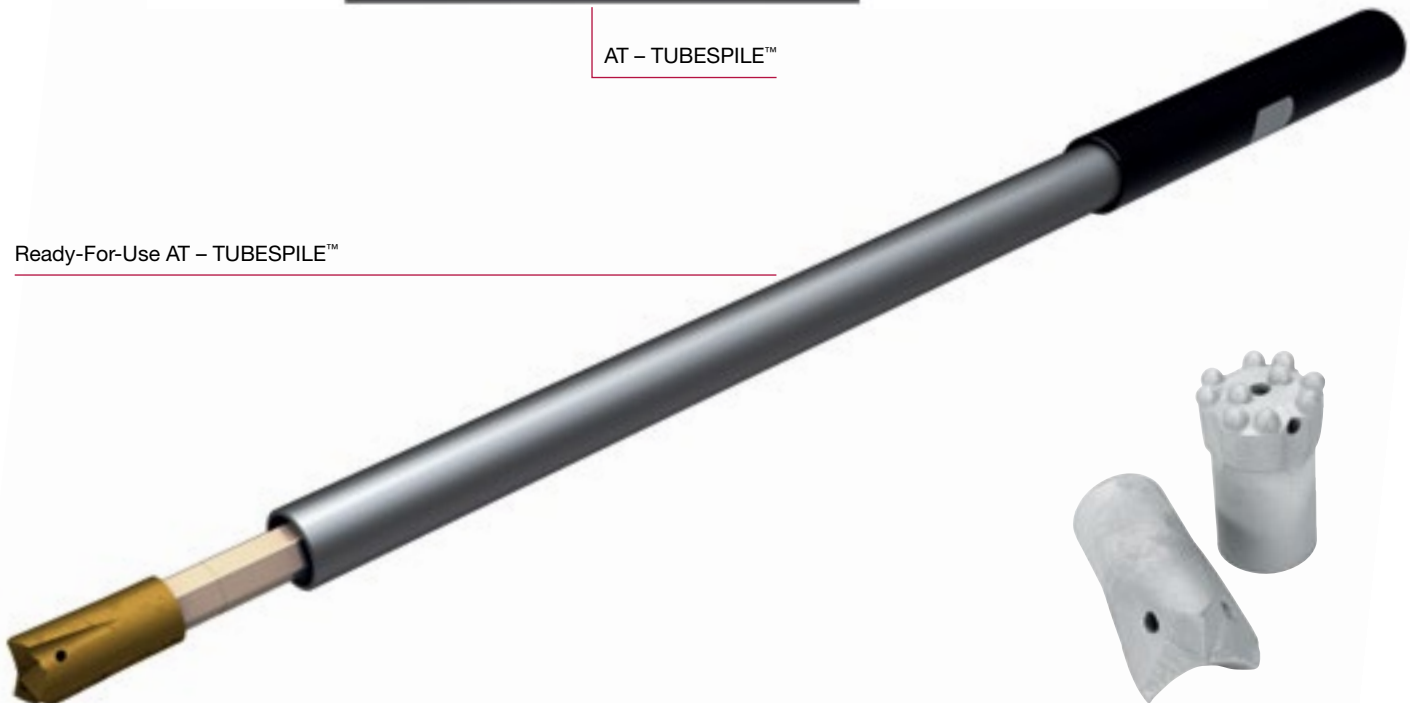

AT – TUBESPILE™

Specifications SI Units

Steel Grade ¹⁾	Modulus of Elasticity [N/mm ²]	Yield Strength [N/mm ²]	Outer Diameter ²⁾ [mm]	Wall Thickness [mm]	Weight [kg/m]	Standard Tube Length [m]	Cross Section [cm ²]	Moment of Inertia [cm ⁴]	Section Modulus [cm ³]	Maximum Moment (Elastic) [kN·m]
S235	210,000	235	51	3.2	3.8	3.0 / 3.5 / 4.0 / 4.5	4.8	13.8	5.4	1.3
				4.5	4.3		6.6	17.9	7.0	1.6
S355 or E355		355		3.2	3.8		4.8	13.8	5.4	1.9
				4.5	4.3		6.6	17.9	7.0	2.5

Specifications US Customary Units

Steel Grade	Modulus of Elasticity [ksi]	Yield Strength [ksi]	Outer Diameter ¹⁾ [in]	Wall Thickness [in]	Weight [lb/ft]	Standard Tube Length [ft]	Cross Section [in ²]	Moment of Inertia [in ⁴]	Section Modulus [in ³]	Maximum Moment (Elastic) [lb·ft]
³⁾	30,500	≥ 35	2.0	0.13	2.6	9.8 / 11.5 / 13.1 / 14.8	0.74	0.33	0.33	960
				0.18	2.9		1.02	0.43	0.43	1,180
⁴⁾		≥ 50		0.13	2.6		0.74	0.33	0.33	1,400
				0.18	2.9		1.02	0.43	0.43	1,840

1) Steel grade S235 and S355 according to EN 10025-2 or E355 according to EN 10296-1

2) Deviating structural properties are available on request

3) Reference steel grade: carbon steel with a minimum yield strength of 35 [ksi]

4) Reference steel grade: carbon steel with a minimum yield strength of 51.5 [ksi]

Technical Features

- Self-drilling installation permits application in all ground types
- Different drill bits for various ground conditions
- Cased installation enables proper installation in poor ground even with unstable borehole walls
- Self-drilling installation ensures proper installation even in frequently changing ground conditions
- High heading accuracy of the spile drills thanks to the guidance of the spile tube
- No annular gap and therefore no settlements or ground loosening during installation
- Back-flushing inside the spile tube features least possible influence of the flushing water on ground properties
- Optionally available with holes for drainage or injection purposes
- Recording and control of the injection through an injection flow-pressure meter

Installation Procedure

1. Attachment of the AT – TUBESPILE™ spile tube and single-use drill bit onto the POWER SET drill rod, connection of the adapter and the rock drill.
2. Rotary-percussive self-drilling installation with a single-use drill bit; back-flushing of the cuttings through the annulus between drill rod and spile tube.
3. Completion of installation after the final drilling depth has been reached.
4. Retraction of the POWER SET drill rod from the installed AT – TUBESPILE™; the single-use drill bit remains inside the borehole.

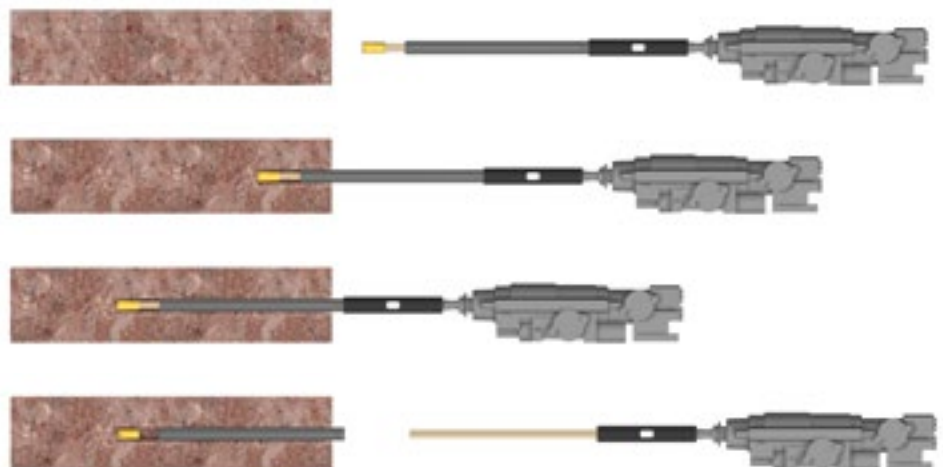

DYWI® Drill Self-Drilling Spiles

Introduction

DYWI® Drill self-drilling spiles form part of the DYWI® Drill Hollow Bar System product range. They are ideal for pre-support measures in all ground types. Especially in unstable boreholes, the fast and self-drilling installation offers distinct advantages compared to conventional spile types.

DYWI® Drill self-drilling spiles support local instabilities in the working area. In poor ground, this system is an excellent alternative to conventional ram spiles or tubular spiles.

Main Advantages

- Installation using conventional drilling machines
- Secure, simple, and fast installation
- Unproblematic application in case of unstable boreholes
- Spile drilling and spile installation in one step
- Greater spile lengths can be achieved with couplings
- Optional grout injection through the hollow bar

System Description

DYWI® Drill self-drilling spiles are installed with conventional drill jumbos using rotary percussive drilling. The installed hollow bar simultaneously serves as drilling rod and pre-support element. The drilling energy is transferred onto the drill bit, which has a larger outer diameter than the hollow bar. Cooling and back-flushing of cuttings is accomplished with water between the borehole wall and the DYWI® Drill self-drilling spiles.



System Components

- DYWI® Drill self-drilling spile, optionally available with injection holes
- Optional couplings for extension
- Spile drill bit or welded-on drill bit

Specifications

Characteristic Value / Type ¹⁾	Unit	R32-210	R32-400	R38-420	R38-550	R51-550	R51-950
Actual external diameter	[mm]	31.1		37.8		49.8	
	[in]	1.22		1.49		1.96	
Delivery lengths ²⁾	[m]	2.0 - 6.0					
	[ft]	6.6 - 19.7					
Modulus of elasticity	[N/mm ²]	205,000					
	[ksi]	29,700					
Moment of inertia ³⁾	[cm ⁴]	3.0	3.9	7.8	18.6	20.4	23.9
	[in ⁴]	0.07	0.09	0.19	0.43	0.49	0.57
Maximum moment (elastic) ⁴⁾	[kN·m]	0.9	1.5	2.2	2.5	4.2	6.2
	[lbf·ft]	665	1,100	1,625	1,845	3,100	4,570

1) Further technical information is included in the section DYWI® Drill

2) Off-size lengths are available on request

3) Calculated with the average internal diameter and the nominal cross-sectional area, rounded

4) Rounded



DYWI® Drill Self-Drilling Spiles

Installation Procedure

1. Assembly of the DYWI® Drill self-drilling spile and connection with the hydraulic rock drill.



2. Rotary-percussive self-drilling installation without casing: single-use drill bit and hollow bar serving as drilling rod; flushing with air, water, or an air-water-mixture.



3. Optional extension with couplings.



4. Decoupling from the drifter, optional subsequent grouting using an injection adapter.



Technical Features

- Comprehensive drill bit portfolio for different ground conditions
- Grouting of the annular gap ensures the load transmission and load-bearing capacity
- Optionally with injection holes for ground improvement capacity



Tubular Spiles and Rebar Spiles

Introduction

Tubular spiles and rebar spiles are universally applicable for pre-support measures. They can be installed into pre-drilled, stable boreholes in jointed rock mass and cohesive soil as well as rammed into soft, homogenous ground.

Main Advantages

- Practice-proven spile systems
- Secure and simple installation
- Universally applicable
- Installation using conventional drilling machines
- Tubular spiles: optionally also available as injection spile



System Description

Tubular spiles consist of a steel tube, which is optionally provided with a welded ram top. Rebar spiles consist of smooth or ribbed steel bars that are pointed on one side. The installation is carried out with conventional drilling machines. Both spile types are either installed into pre-drilled spile holes or rammed into the ground. Pre-drilled spiles are used for jointed rock mass and cohesive soil as pre-support against falling rock mass, whereas ram spiles are applied in homogenous, soft ground.

By ramming, the stress situation is preserved, and an optimum initial condition for arching between the spiles is achieved. Following driving, the load of the ground is transferred to the bearings by the spiles. Those bearings are the ground ahead of the face, and the support arch in the already supported excavation area (primary lining).



Technical Features Tubular Spiles

- Simple and uncomplicated installation into pre-drilled boreholes
- Tubular ram spiles with steel point are available on request
- Ground preserving installation by ramming – the original stress condition remains
- Ramming displaces the ground and allows for optimum load carrying characteristics at a later stage
- Installation is possible above as well as through the support arch
- High section modulus in relation to the weight
- Also available as injection spile with injection holes for ground improvement

Specifications Tubular Spiles

Characteristic Value / Type ¹⁾	Unit	38 x 4.0	51 x 3.2	51 x 4.5
Actual external diameter	[mm]	38	51	
	[in]	1.5	2.0	
Wall thickness	[mm]	4.0	3.2	4.5
	[in]	0.16	0.13	0.18
Delivery lengths ²⁾	[m]	3.0 / 4.0 / 6.0		
	[ft]	9.8 / 13.1 / 19.7		
Modulus of elasticity	[N/mm ²]	210,000		
	[ksi]	30,450		
Moment of inertia	[cm ⁴]	6.3	13.8	17.9
	[in ⁴]	0.15	0.33	0.43

1) Minimum steel grade S235 (EN 10025-2). Alternatively, a carbon steel with a minimum yield strength of 35 [ksi] is required

2) Off-size lengths and optional injection holes are available on request

Installation Procedure Tubular Spiles

- Installation into pre-drilled spile holes
 - Pre-drilling of spile holes through or above the support arch
 - Insertion of tubular spiles
- Installation as tubular ram spile
 - Ramming of tubular spiles through or over the support arch
 - Ram adapters available on request



Technical Features Rebar Spiles

- Simple and uncomplicated installation into pre-drilled spile holes
- Grouted annular gaps improve load transfer to the ground
- Ramming is an installation method which retains the original stress condition
- The ground is displaced by ramming; this permits optimum conditions for subsequent load carrying
- Installation is possible above as well as through support arches

Installation Procedure Rebar Spiles

- Installation into pre-drilled spile holes
 - Pre-drilling of the spile holes through or above the support arch
 - Filling of the spile holes with grout (only for grouted installation)
 - Installation of the rebar spile
- Installation as rebar ram spile
 - Ramming of the rebar spiles through or above the support arch

Specifications Rebar Spiles

- Spiles from smooth or ribbed concrete steel
- Minimum steel grade B 500 B (OENORM B 4700 or DIN 488-1) or grade 75 (ASTM A615)
- Bar diameters 20 [mm] to 36 [mm] or #6 to #11
- Delivery lengths 3 [m] to 6 [m] or 9.8 [ft] to 19.7 [ft]
- Pointed on one side
- Deviating lengths and unpointed rebar spiles are available on request

Forepoling Boards

Introduction

Forepoling boards are used for laminar-active pre-support, which is particularly suitable for unstable, non-cohesive ground. This support is rammed into the ground using hydraulic drifters.



Main Advantages

- Installation using conventional drilling machines
- Secure and simple installation
- Closed support at the open span
- Ramming minimizes drive-induced ground stress relaxation

System Description

Forepoling boards are rammed above the support arch in a single step with conventional drill booms via a ram shoe. They are either installed overlapping or with a gap when the ground shows little cohesion.

- Steel plate with one or two longitudinal seams
 - Plate thickness: 3 - 6 [mm] (1/8 - 15/64 [in])
 - Length: 1.25 - 3.0 [m] (4.1 - 9.8 [ft])
 - Width: approx. 220 [mm] (8 21/32 [in])
- Forepoling board template
 - Different versions available on request
- Forepoling boards with deviating structural properties are available on request

Technical Features

- Ramming with hydraulic rock drills
- Secure and simple installation
- Ramming prevents settlement and stress release ahead of the excavation

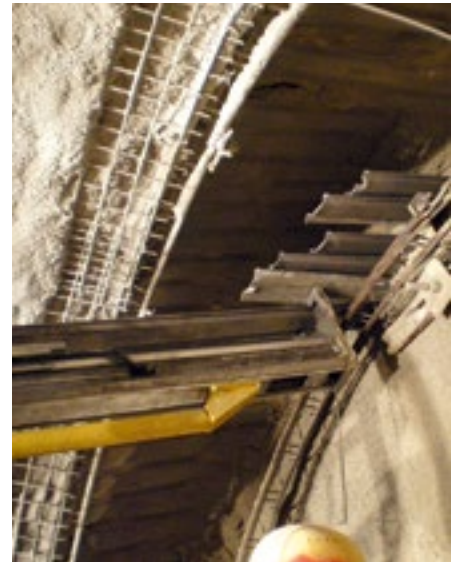

Forepoling Boards

Schematic Drawing Type A and Type B

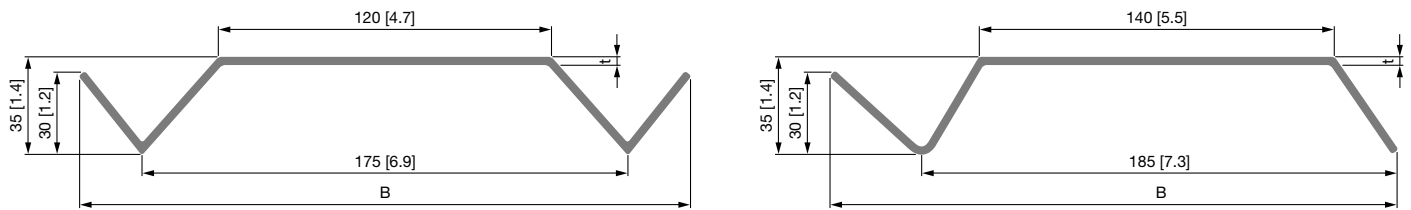

Specifications

SI Units

Characteristics	Symbol	Unit	A3 / B3					A4 / B4					A5 / B5					A6 / B6				
Thickness	t	[mm]	3					4					5					6				
Length ¹⁾	L	[m]	1.25	1.50	2.00	2.50	3.00	1.25	1.50	2.00	2.50	3.00	1.25	1.50	2.00	2.50	3.00	1.25	1.50	2.00	2.50	3.00
Width ²⁾	W	[mm]	220					220					220					220				
Weight	m	[kg/m]	6					8					10					12				
Weight per piece	m _{Pcs}	[kg]	7.5	9.0	12.0	15.0	18.0	10.0	12.0	16.0	20.0	24.0	12.5	15.0	20.0	25.0	30.0	15.0	18.0	24.0	30.0	36.0
Section modulus	W _x	[cm ³]	8.9					10.6					12.2					13.8				

US Customary Units

Characteristics	Symbol	Unit	A3 / B3					A4 / B4					A5 / B5					A6 / B6				
Thickness	t	[in]	0.12					0.16					0.20					0.24				
Length ¹⁾	L	[ft]	4.1	4.9	6.6	8.2	9.8	4.1	4.9	6.6	8.2	9.8	4.1	4.9	6.6	8.2	9.8	4.1	4.9	6.6	8.2	9.8
Width ²⁾	W	[in]	8.7					8.7					8.7					8.7				
Weight	m	[lb/ft]	4.0					5.4					6.7					8.1				
Weight per piece	m _{Pcs}	[lb]	17	20	26	33	40	22	26	35	44	53	28	33	44	55	66	33	40	53	66	79
Section modulus	W _x	[in ³]	0.54					0.65					0.74					0.84				

1) Special lengths available on request

2) Reference width including overlapping: 5.7 pieces per [m] or 1.7 pieces per [ft]







Drainage and Injection

Fields of Application

AT – TUBESPILE™ Vacuum Lances

- Drainage works around the excavation
- Drainage with and without vacuum application
- Drainage works in challenging ground conditions

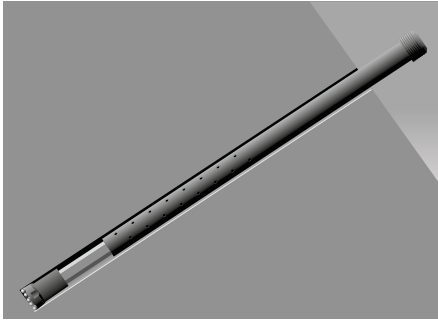

AT – Drainage System

- Far-ranging drainage works
- Drainage of the ground ahead of the advance and parallel to construction
- Reduction of water pressure in fault zones ahead of excavation

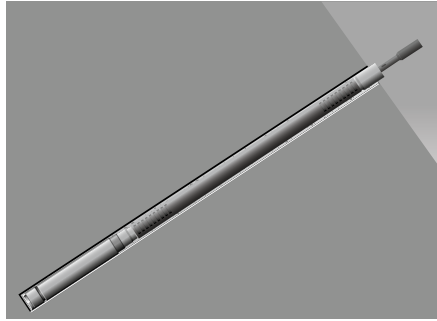

- Stabilization of water-saturated slopes
- Reduction of the water pressure behind construction walls
- Drainage works in challenging ground conditions

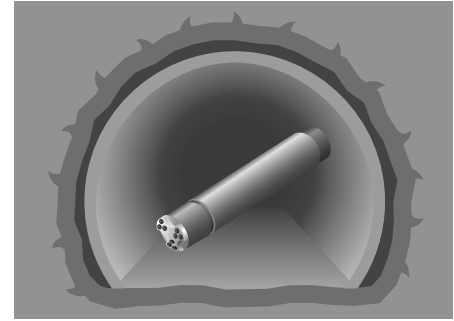

Chemical Injection

Chemical injection systems are widely used both in conventional excavation (NATM/SEM) and mechanized Tunneling for the following purposes:

- Sealing
- Stabilization
- Filling
- Bonding

Each and every chemical injection application is different and requires experienced personnel, high-quality resin material, and the availability of proper accessories and equipment.

DSI Underground has experienced personnel to support both planning and implementation of injection programs.

DSI Underground offers a compact series of the following chemical injection resin systems:

- DYWI® Inject PURE - polyurethane waterstop
 - PURE 8031: high-foaming to stop flowing water
 - PURE 8032: consolidation and sealing of pressing water
 - PURE 8034: slightly foaming for ground consolidation

- DYWI® Inject SILO - silicate
 - SILO 8041: high-foaming with fine cell structure
 - SILO 8042: multi-purpose non-foaming
 - SILO 8044-M: thixotropic bolting resin

PURE and SILO type injection resins from the DYWI® Inject product family consist of two components and are processed with 2-component high pressure pumps at a volume ratio of 1:1.

DYWI® Inject Systems are stable for storing and processing, mixed and cured injection resins are ecologically inoffensive.

Pumps and Accessories

- Injection and grouting works
- Ground anchors, micropiles, and bolts
- Grouted spiles and pipe umbrellas
- Backfilling



Injection Monitoring

- Comprehensive documentation of injection and grouting
- Real time data recording of pressure, flow and injection volume
- Evaluation and review of injection results



DYWI® Seal

- Protection of structures against ground water
- Permanent waterproofing of tunnels
- Application in structural engineering: waterproofing of basements, parking garages, or flat roofs

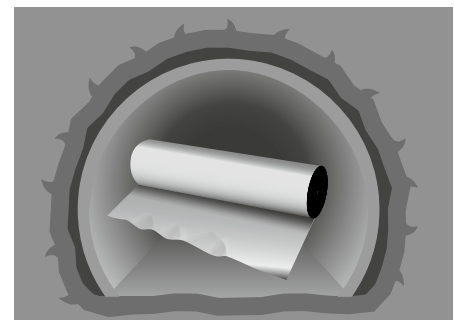

Contents

AT – TUBESPILE™ Vacuum Lances	170
AT – 76 Drainage System.....	173
Chemical Injection	176
Cement Injection	182
Pumps and Accessories	182
Injection Monitoring	183
Waterproofing.....	184



AT – TUBESPILE™ Vacuum Lances

Introduction

The AT – TUBESPILE™ vacuum lance forms part of the POWER SET product family. The system consists of an exterior steel tube with a PVC drainage tube inserted after drilling. The main field of application is the temporary or semi-temporary drainage of ground around the excavation geometry in Tunneling and special foundation engineering.

Main Advantages

- Installation using standard drilling machinery
- Simple and robust system components
- Secure and simple installation
- Drainage drilling and casing installation in one operational step
- Ground preserving, self-drilling installation



System Description

AT – TUBESPILE™ vacuum lances are installed rotary-percussive in one step using a conventional drill boom. A drill rod inside the casing tubes transfers the drilling energy onto the drill bit, which is available either as button drill bit with carbide inserts or hardened arc-shaped drill bit.

The AT – TUBESPILE™ with drainage openings is pushed through an adapter directly behind the drill bit. Cooling, flushing, and back-flushing of the borehole cuttings are carried out using water inside the casing tube. To finish the installation, a PVC filter pipe is inserted into the casing. In case of vacuum drainage, a drainage hose can be fastened to the vacuum lance following installation.



AT – TUBESPILE™ Vacuum Lances

System Components

- AT – TUBESPILE™ drill bit
 - Single-use drill bits Ø 52 [mm] (Ø 2 3/64 [in]) available as arch-shaped or button drill bits
- AT – TUBESPILE™ vacuum lance
 - Ø 51 x 3.2 [mm] (Ø 2 x 1/8 [in]) with drainage openings and 2" connecting thread
- POWER SET drill rod
 - Special drill rod for high service life
- POWER SET coupling adapter
 - Controlled transfer of the impact energy onto the AT – TUBESPILE™
- AT – TUBESPILE™ filter pipe



Ready-For-Use AT – TUBESPILE™ Vacuum Lance



Specifications ¹⁾

System	Material	Outer Diameter		Wall Thickness		Weight		Standard Lengths	
		[mm]	[in]	[mm]	[in]	[kg/m]	[lb/ft]	[m]	[ft]
AT – TUBESPILE™ with drainage openings	Steel ²⁾	51	2.0	3.2	0.13	3.8	2.6	3 / 3.5 / 4 / 4.5	9.8 / 11.5 / 13.1 / 14.8
Filter pipe	PVC ³⁾	44	1.7	3.5	0.14	1.6	1.1	3.0	9.8

1) Different dimensions are available on request

2) Steel grade ≥ S235 according to EN 10025-2 or reference steel grade 35 [ksi]

3) Slot opening width 0.6, 1.0, and 1.5 [mm] (1/32, 3/64, and 1/16 [in]); 3 slots around the whole pipe circumference

Technical Features

- Self-drilling installation permits application in all ground conditions
- Number of drainage holes and filter slot size are adaptable
- Different drill bit types are available
- Cased installation allows proper installation even in frequently changing or poor ground conditions
- No annular gap and therefore no settlement or loosening during installation

AT – TUBESPILE™ Vacuum Lances

Installation Procedure

1. Attachment of the AT – TUBESPILE™ vacuum lance and the AT – TUBESPILE™ single-use drill bit onto the POWER SET drill rod, connection of the POWER SET coupling adapter to the hydraulic rock drill.
2. Rotary-percussive self-drilling installation with a single-use drill bit; flushing of the cuttings through the annular gap between the drill rod and the AT – TUBESPILE™ vacuum lance.
3. Completion of the drilling process after reaching the drilling depth.
4. Retraction of the POWER SET drill rod from the installed AT – TUBESPILE™ vacuum lance; the single-use drill bit remains in the borehole.
5. Insertion of a filter tube into the AT – TUBESPILE™ vacuum lance.
6. Optional connection of a drainage hose and coupling onto a vacuum pump.



Accessories

- Vacuum pump
- DYWI® Inject Systems
- Injection packers



AT – 76 Drainage System

Introduction

The AT – Drainage System is used for deep reaching drainage and forms part of the AT-SYSTEM product family. It is used in Tunneling and in Civil Engineering for draining of the surrounding ground and consists of an inner steel tube which is wrapped with a PVC drainage pipe. The AT – Drainage System can be applied temporarily as well as semi-permanently. Examples of application are drainage works parallel to tunnel advances or water saturated slopes.

Main Advantages

- Installation using conventional drilling machines
- Execution of the drilling works can be carried out by on-site personnel guided by application engineers
- Time-saving self-drilling installation thanks to simultaneous drilling and casing
- Installation is also possible in flowing and ravelling ground conditions
- Length of the drainage tubes adaptable to little space

System Description

The AT – Drainage System is installed piecewise by rotary-percussive drilling with conventional drill booms. Cooling, flushing, and back-flushing of the cuttings take place inside the drainage tube.



AT – 76 Drainage System

System Components

AT – Drainage Starter Unit with Drill Bit



AT – Drainage Extension Tube



AT – Drainage End Tube



Different AT – Drill Adapters



Coupling Adapter and Drill Rods



End Cap



Ready-For-Use AT – Drainage System
AT – 76/DR Starter Unit with DR Extension Tube



Specifications ¹⁾

System	Inner Tube Material	Filter Pipe ³⁾ Material	Outer Diameter		Weight		Standard Tube Length	
			[mm]	[in]	[kg/m]	[lb/ft]	[m]	[ft]
AT – 76/DR	Steel ²⁾	PVC	76.1	3.0	7.0	4.7	3.0	9.8

1) Different dimensions are available on request

2) Steel grade ≥ S235 according to EN 10025-2 or reference steel grade 35 [ksi]

3) Slot opening width 0.6, 1.0, and 1.5 [mm] (1/32, 3/64, and 1/16 [in]); 3 slots around the whole pipe circumference



Technical Features

- Fast length adaption of drainage tubes by piecewise installation
- Simple extension of drainage tubes even in limited space
- High directional accuracy of drainage drillings
- Drainage pipes can be flushed for cleaning when installed as a permanent measure

Installation

1. The AT – DR-Starting Unit with drill bit is prepared for installation with the first AT – Drainage Extension Tube, the AT – Drill Adapter, and the drill rod on the drill boom.
2. Drilling of the first AT – Drainage Extension Pipe.
3. The next drill rod including the AT – Drainage Extension Tube is connected to the previously installed part and is subsequently drilled.
4. Repetition of the last step until the planned length of the drainage drilling has been reached.

Accessories

- Chain pipe and drill rod wrench
- Rock drilling equipment: shank adapter, coupling, and coupling adapter
- Fishing tab
- Centralizer



Chemical Injection

System Solutions

Product Group	PURE 8031	PURE 8032	PURE 8034	SILO 8041	SILO 8042	SILO 8044-M
Product Designation	Polyurethane Injection Foam Resin	Polyurethane Injection Resin	Polyurethane Injection Resin	Silicate Injection Foam Resin	Silicate Injection Resin	Silicate Bolting Resin
Water ingress	X	X	X	X	X	X
Pressing water		X			X	
Leaking gas		X			X	X
Rock stabilization		X	X	X	X	
Ground improvement	X			X		
Filling of cavities				X		
Bolt bonding			X		X	X

Sealing

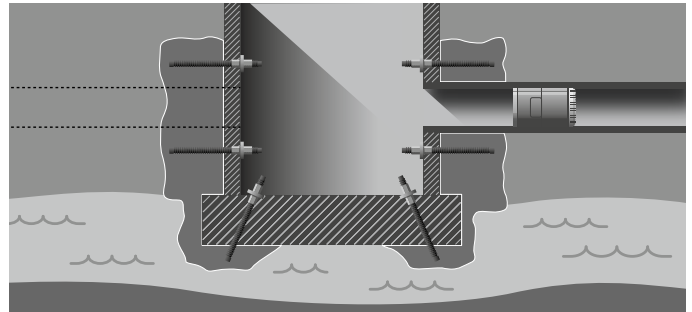
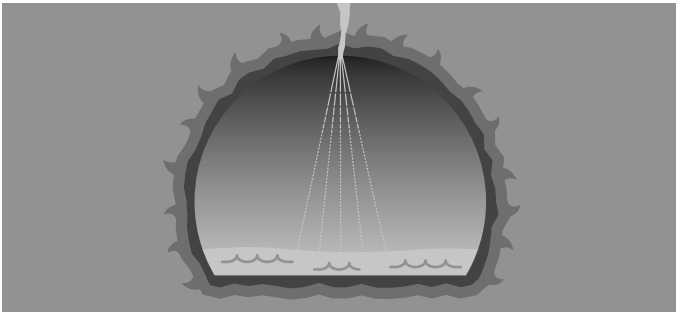

Stabilization

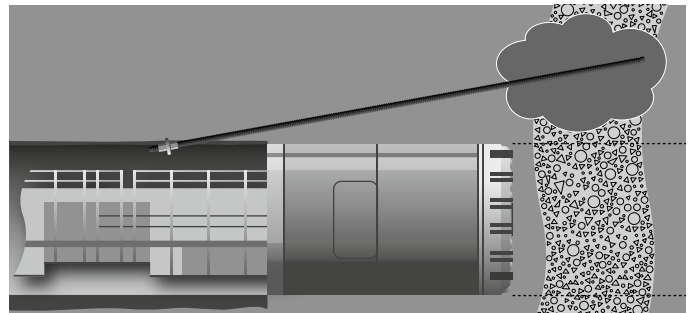
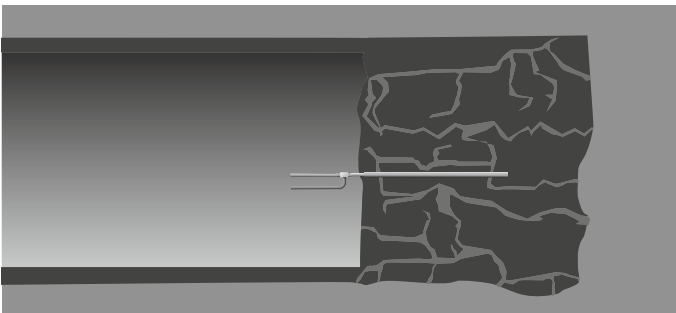

Filling

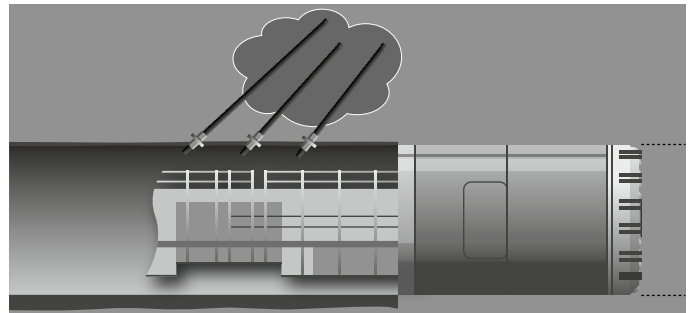
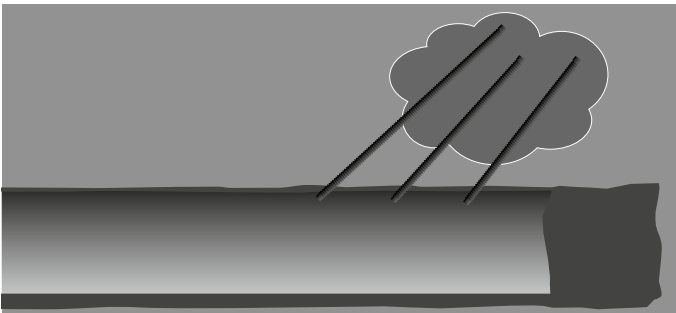

Bonding

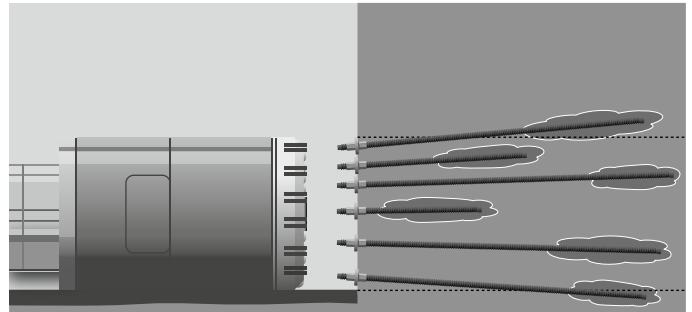
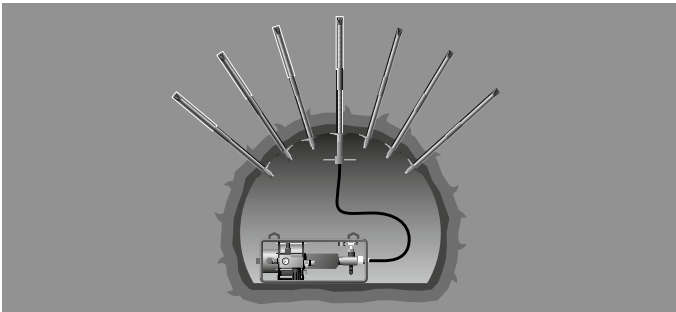

Chemical Injection

Introduction

DYWI® Inject Systems are 2-component chemical injection resins used Underground. PURE type polyurethane systems are mainly used for waterstop applications, injection resins type SILO are silicate-based and popular ahead of mechanical excavation and for bolting. All DYWI® Inject Systems are processed with 2-component high pressure pumps at a volume ratio of 1:1.

Mixed and cured injection resins are ecologically inoffensive – CFC and halogen free – and suitable for application in drinking water areas.

Furthermore, DYWI® Inject Systems are stable for storing and processing, as well as resistant against acids and bases.



DYWI® Inject PURE - Polyurethane Waterstop

PURE 8031

- Short reaction and curing times
- High foaming injection resin
- Quick stopping of flowing water
- Excellent adhesive capacity

PURE 8032

- Multi-purpose injection resin
- Slightly foaming upon contact with water
- Consolidation and sealing of water
- Accelerator: PURE X 8032 F
- Thixotropic agent: PURE X 8032

PURE 8034

- Slightly foaming injection resin
- Well-suited for ground improvement
- High penetration ability



Chemical Injection

DYWI® Inject PURE - Polyurethane Waterstop

Specifications

Properties ¹⁾	Unit	PURE 8031	PURE 8032	PURE 8034
Mixing ratio	[1]		1:1 parts by volume	
Curing time 20 [°C] / 68 [°F]	[s]	Approx. 10	—	70 ± 15
Curing time 30 [°C] / 86 [°F]	[s]	Approx. 33	55 ± 15	110 ± 25
Foam factor	[1]	Up to 30	Up to 7 (upon water contact)	1 - 4

1) The indicated values are laboratory values and may deviate on-site. Store in original packaging and protected from moisture at temperatures between 5 [°C] and 30 [°C] (41 [°F] and 86 [°F])



DYWI® Inject SILO - Consolidation

SILO 8041

- High foaming injection resin
- Flexible foam with fine cell structure
- Ground improvement and cavity filling
- Reaction with and without water
- Cured foam is easy to cut

SILO 8042

- Multi-purpose injection resin
- Sound adhesive properties
- Non-foaming
- Ground consolidation
- Rock stabilization
- Reaction with and without water



Specifications

Properties ¹⁾	Unit	SILO 8041	SILO 8042
Mixing ratio	[1]	1:1 parts by volume	
Curing time 20 [°C] / 68 [°F]	[s]	20 ± 10	—
Curing time 30 [°C] / 86 [°F]	[s]	45 ± 15	80 ± 10
Foam factor	[1]	20 - 40	1

1) The indicated values are laboratory values and may deviate on-site. Store in original packaging and protected from moisture at temperatures between 5 [°C] and 30 [°C] (41 [°F] and 86 [°F])

Chemical Injection

DYWI® Inject SILO - Silicate Bolting

Introduction

DYWI® Inject SILO 8044-M is a 2-component silicate bolt resin with excellent adhesive properties that cures quickly and solidly.

The easy working principle, a 1:1 parts by volume mixing ratio, and extensive Underground field testing characterize this injection resin system and provide

ideal prerequisites to fulfill requirements for Underground applications.

DYWI® Inject SILO 8044-M has been globally used for bonding cable bolts and GRP bars and hollow bars, as well as in combination with the DYWI® Drill Hollow Bar System.

Main Advantages

- Proven system for application Underground
- Easy overhead installation of bolts
- Cures quickly and solidly
- Good adhesive properties
- High ultimate strength and immediate load-bearing capacity after installation
- Chemical persistence
- Optimized installation cycle times compared to cement grouted bolting operations

System Description

- Thixotropic silicate bonding system for bolting operations
- Non-foaming
- Rapid and stable curing
- Approved application with DYWI® Drill and GRP hollow bars



Chemical Injection

DYWI® Inject SILO - Silicate Bolting

Specifications

Properties ¹⁾	Unit	SILO 8044-M
Mixing ratio	[1]	1:1 parts by volume
Curing time 20 [°C] / 68 [°F]	[s]	210 ± 30
Curing time 30 [°C] / 86 [°F]	[s]	120 ± 30
Compressive strength	[MPa] / [psi]	21 / 3,050

1) The indicated values are laboratory values and may deviate on-site. Store in original packaging and protected from moisture at temperatures between 5 [°C] and 30 [°C] (41 [°F] and 86 [°F])

Installation Procedure

Cable Bolts

- Drilling of the borehole
 - According to given specifications with regards to diameter and length
- Insertion of the cable bolt into the borehole
 - With end holding device
 - Attached grout tube
 - Default bulbed version
- Optional sealing of the borehole collar
 - Spray foam or borehole plug
- Injection DYWI® Inject SILO 8044-M
 - Top down via the injection tube – connection of the injection tube to the static mixer via a quick connector coupling
- Tensioning
 - Fast curing time allows full cable tensioning within less than 30 minutes after installation

DYWI® Drill Hollow Bar System or GRP Hollow Bars Type CH or CR

- Self-drilling installation or insertion into a pre-drilled borehole
 - Optional use of an end holding device
- Sealing of the borehole collar
 - Spray foam or borehole plug
- Injection DYWI® Inject SILO 8044-M
 - Resin flow upwards through the hollow bar, bottom down injection
- Tensioning
 - Fast curing time allows tensioning within less than 30 minutes after installation



Cable Bolt

DYWI® Drill



GRP Hollow Bar

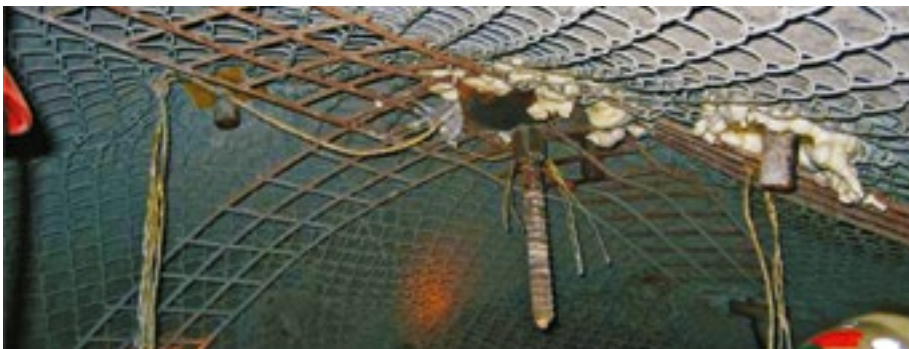

Further References

- Safety data sheets EG No. 1907/2006
- Technical data sheets
- Instructions for mixing and processing, cleaning and disposal, health and safety

Chemical Injection

Pumps and Accessories

DYWI® Inject 2-Component High-Pressure Pumps

- Brace operated, pneumatically driven piston pump
- 1:1 mixing ratio for processing DYWI® Inject Systems
- Independent intake of both components
- Robust design and little susceptibility to damage
- Easy operation and handling
- Spare parts and starter set available
- Technical data sheet and operation manual available on request



Accessories

- Mixing tubes and static mixers
- Connectors
 - Injection adapters (DYWI® Drill and GRP)
 - Quick connectors (cable bolts)
- Screw-on nipples
- DYWI® Drill and GRP injection lances
- Steel and plastic injection lances
- Injection deep packers

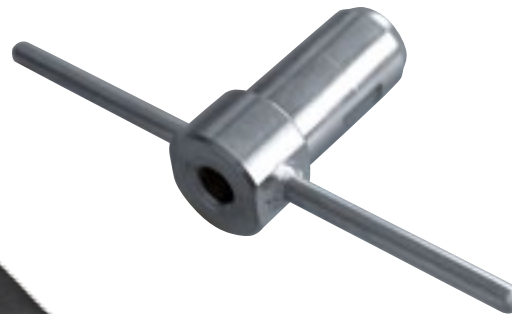

Cement Injection - Pumps and Accessories

DSI MAI® Grout Mixing Pumps

Introduction

DSI MAI® grout mixing pumps have been developed for extremely challenging Underground conditions. They have been used successfully around the world in Tunneling and Civil Engineering, for example for the shoring of slopes, hill sides, and building excavations.

The standard product portfolio consists of the following three types:

- DSI MAI® 400 EASY PLUS: Multi-purpose light version

- DSI MAI® 400 NT: Tunneling
- DSI MAI® 440 GE: special foundations

The proven and delivery technology is suitable for:

- Injection and grouting works
- Re-injection
- Drill hole filling
- Backfilling



Main Advantages

- Tough design and easy handling
- Low empty weight
- Simple operation and maintenance due to modular design
- Low start-up and cleaning times
- High delivery rate at continuous pressure
- Variable discharge
- All-purpose equipment
- Highest process security
- Sustainable due to stainless steel components, galvanized frame, and wear resistance plastic components
- Comfortable cleaning
- Automatic reverse drive

System Components

- Pump unit
- Mixer
- Driving unit
- Protective grid with bag opener
- Grout mixing pumps with CSA approval available on request

Accessories

- Tools
- Water pump
- Automatic polarity control
- Cleaning equipment
- Compressor
- Spray and filler guns
- Cover hood for silo feeding
- Dosing pump for additive dosage
- Pressure sensors for grouting
- Injection flow-pressure meter DSI MAI® LOG400 for data recording

Specifications

Characteristic Value / Type	Unit	DSI MAI® 400 EASY PLUS	DSI MAI® 400 NT	DSI MAI® 440 GE
Nominal power	[kW]	4.0	6.2	10.0
	[hp]	5.4	8.3	13.4
Gear motor	[rpm]	290	200	220
Delivery rate	[L/min]	16	6 - 35	5 - 60
	[gal/min]	4.2	1.6 - 9.2	1.3 - 15.9
Operation pressure	[bar]	33	40	max. 45
	[psi]	480	580	max. 650
Length	[mm]	1,520	1,730	1,570
	[in]	60	69	62
Width	[mm]	580	570	750
	[in]	23	22	30
Height	[mm]	900	960	1,030
	[in]	35	38	41
Filling height	[mm]	1,050	960	1,030
	[in]	41	38	41
Total weight	[kg]	136	213	360
	[lb]	300	470	794

Cement Injection – Injection Monitoring

Injection Flow-Pressure Meter DSI MAI® LOG400

Introduction

The revolutionary injection flow-pressure meter DSI MAI® LOG400 permits an exact and comprehensible documentation of ground improvement as well as a control system of the specified injection termination criteria.

The appliance, designed for rough job site missions, controls and supervises

the use of injection-pumps in Tunneling and Civil Engineering. The flow rate and pressure measuring device is a separate, flexible module, which can be connected directly to an injection pump.



Main Advantages

- Tough design and easy handling
- Real time data recording of pressure, flow and injection volume
- Automatic analysis of the working data
- Data transfer via compact-flash-card or USB
- Software for easy data transfer into a spreadsheet program
- Mountable on a tripod – for optimized handling on job sites
- Auto-power-off if defined pressure and/or volume is exceeded
- Pump control with the DSI MAI® 400 GE and 400 NT possible
- Adjustments: operators can make adjustments themselves depending on the type of used material
- Measuring unit can be configured:
 - Pressure bar: 6 - 40 bar (90 - 580 [psi])
 - Flow rate: 4 - 12 [m³/h] (140 - 425 [ft³/h])

System Description

Flow rates and injection pressures are recorded separately for each injection borehole. The manipulation-proof digital data recording is operated via a user-friendly and simple touch-screen terminal. The easy handling and the integrated software, which allows

the input of the working data into a spreadsheet calculation program, are a benefit for each job site.

The acquired data is shown in real time. Thanks to the DSI MAI® LOG400 data-import-software, all recorded data can

easily be transported to a laptop or PC into a spreadsheet program. There, the data evaluation is shown in terms of a consolidated overview with graphics and tables.



Waterproofing

Introduction

The DYWI® Seal waterproofing system is a needle-punched non-woven impregnated membrane. The membrane structure comprises water absorbing and water swelling polymers. An optional one-side polyethylene film on top of the needle-punched non-woven membrane and the self-healing properties of the DYWI® Seal waterproofing system ensure optimum performance for various water sealing applications.

Bentonite mats, also referred to as geosynthetic clay liners (GCL's), are barriers used for various sealing and waterproofing applications. DYWI® Seal bentonite mats are a composite consisting of two layers of geotextiles filled with sodium bentonite.

The application range of DYWI® Seal bentonite mats comprises waterproofing, gas sealing, and usage as a vapor barrier.



Waterproofing

DYWI® Seal Waterproofing System

- Penetrating ground water causes an immediate reaction of the swelling polymers – the DYWI® Seal waterproofing system is absolutely watertight
- Super absorbent polymers (SAP's) feature optimum swelling capacity
- Permanent protection against penetrating water
- Sealing effect up to 2.5 [bar] (36 [psi]) water pressure – higher pressure resistance available on request
- Installation independent on climate conditions and temperatures
- Overlapping areas are glued to achieve an absolutely watertight effect
- Tough and resistant
- High shear strength



DYWI® Seal Bentonite Mats

- Mechanically bonded composite, consisting of pulverized or granulated bentonite, embedded and fixed between two layers of geotextile
- Flexible installation of DYWI® Seal bentonite mats, which are simply rolled out
- Additional sealing of the overlapping area with sodium bentonite powder
- The sealing layer is covered once installation has been completed
- Permanent sealing mechanism by single reaction of the sodium bentonite upon water contact
- The main parameters of DYWI® Seal bentonite mats are their weight, swelling capacity, and the coefficient of permeability
- Supply of an additional bag of bentonite powder with each roll for application in the overlapping areas
- Minimum durability of 25 years at a pH value range between 4 and 9 and a temperature of < 25 [°C] (77 [°F])
- Application in combination with DYWI® Seal waterproofing system on request







Mechanized Tunneling

Introduction

In accordance with global state-of-the-art methods in Tunneling, conventional (NATM/SEM) and mechanized excavation are the most common ones.

DSI Underground has always put a focus on the special demands in mechanized Tunneling and is now able to provide a comprehensive portfolio of ground control solutions which ensure a safe and efficient excavation.

Depending on the excavation type and given ground conditions, mechanized Tunneling goes along with project-specific requirements on ground control systems, excavation technology, and occupational safety.

Main requirements are as follows:

- Stabilization of the excavation perimeter during driving
- Filling and sealing of cavities
- Sealing against water inflow
- Flexible adjustments with regards to changes in ground conditions
- Pre-support measures in the area of fault zones
- Stabilization and protection of the Tunneling machine
- Minimization of displacements in urban areas

Basically, Tunneling machines are classified into tunnel boring machines (abbreviation TBM's) and shield machines (SM's). TBM's are mainly used for principle hard ground and SM's for principle soft ground conditions.

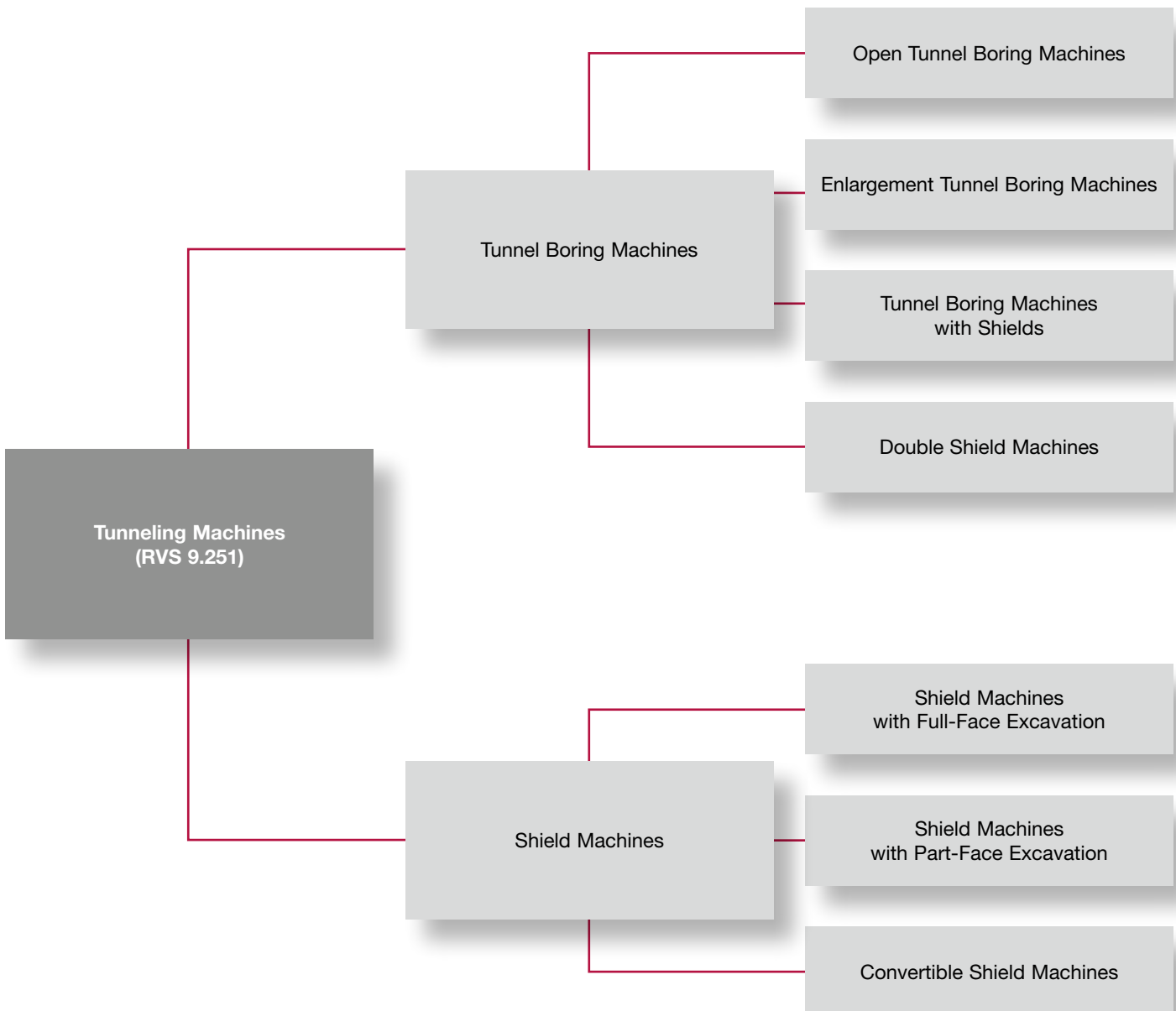

Mechanized Tunneling

Introduction

A safe and economically feasible implementation of each construction project always has the highest priority. Both in conventional and mechanized Tunneling, innovative and high quality ground control systems are key. Besides decades of expertise, DSI Underground offers the widest product range available on the market.

- Segmental lining
 - Connection and alignment systems
 - BULLFLEX® structural sealings
- Chemical injection and sealing solutions
 - AT – GRP Injection System
 - GRP injection lances
 - DYWI® Inject Systems
- Passive steel support
 - Liner plates
 - Ribs
- Forepoling systems
 - DYWI® Drill hollow bar spiles
 - AT – TUBESPILE™
 - AT – Pipe Umbrella Support System
- Anchors and bolts
 - DYWI® Drill Hollow Bar System
 - OMEGA-BOLT® expandable friction bolts
 - POWER SET S-D friction bolts
 - GRP bolts
 - Mesh
- Equipment
 - Attachment units for semi or fully automated installation of ground control solutions
 - Grouting, injection, and backfilling pumps
 - Injection flow-pressure meters and injection data loggers



Mechanized Tunneling

Fields of Application

Forepoling

- DYWI® Drill Hollow Bar spiles
- AT – TUBESPILE™

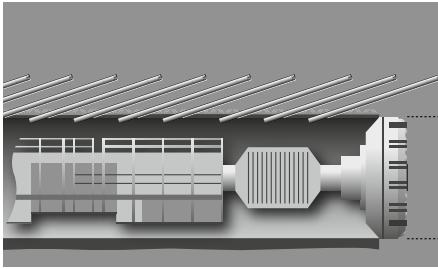

Filling of Cavities

- DYWI® Inject Systems
- GRP injection lances

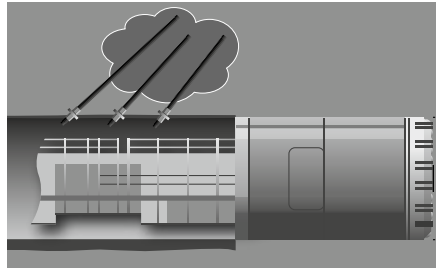

Ground Stabilization

- DYWI® Inject Systems
- GRP injection lances

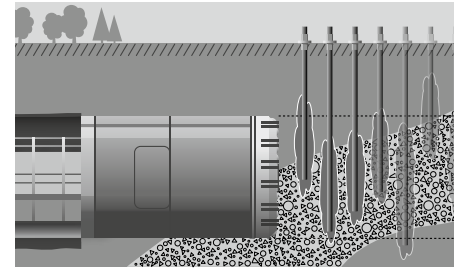

Soft Eyes and Cross-Cuts

- GRP Bolts
- DYWI® Inject Systems

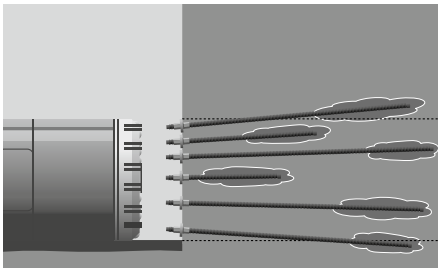

Fault Zone Consolidation

- AT – GRP Injection System
- DYWI® Inject Systems

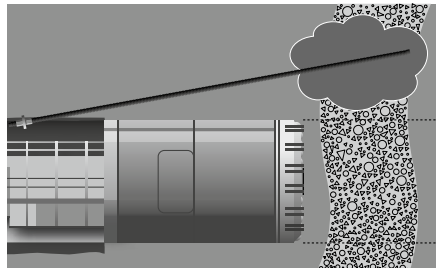

Sealing against Water

- DYWI® Inject Systems

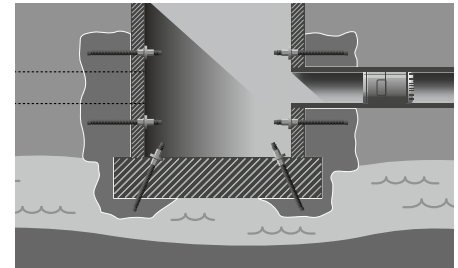

Segment Connection

- Bolting system
- Connection and alignment system

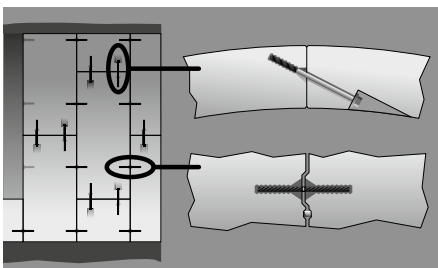

Segment Accessories

- Grouting and lifting sockets
- Segment packers

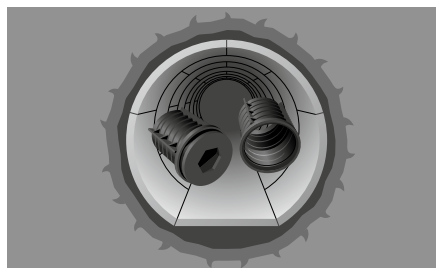

Structural Sealings

- BULLFLEX®

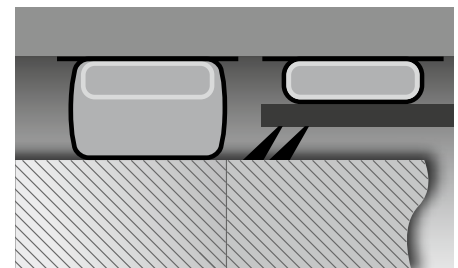

BULLFLEX® Structural Sealings

- O-ring sealing membrane, installed in the annulus between lining segment rings and outer shell or ground
- Sealing against water (liquids) and compressed air
- Launch and receptions of tunnel driving machines
- Sealing or re-lining of existing tunnels

- Sealing of annular gaps in civil structures
- Protection and stabilization of the cutterhead during a repair process

AT – GRP Injection System

- Ground improvement combined with mechanical excavation
- Waterproofing measures near openings and excavations
- Waterproofing measures in water-bearing fault zones

Contents

Segmental Lining Accessories	192
BULLFLEX® Structural Sealings	194
AT – GRP Injection System.....	201

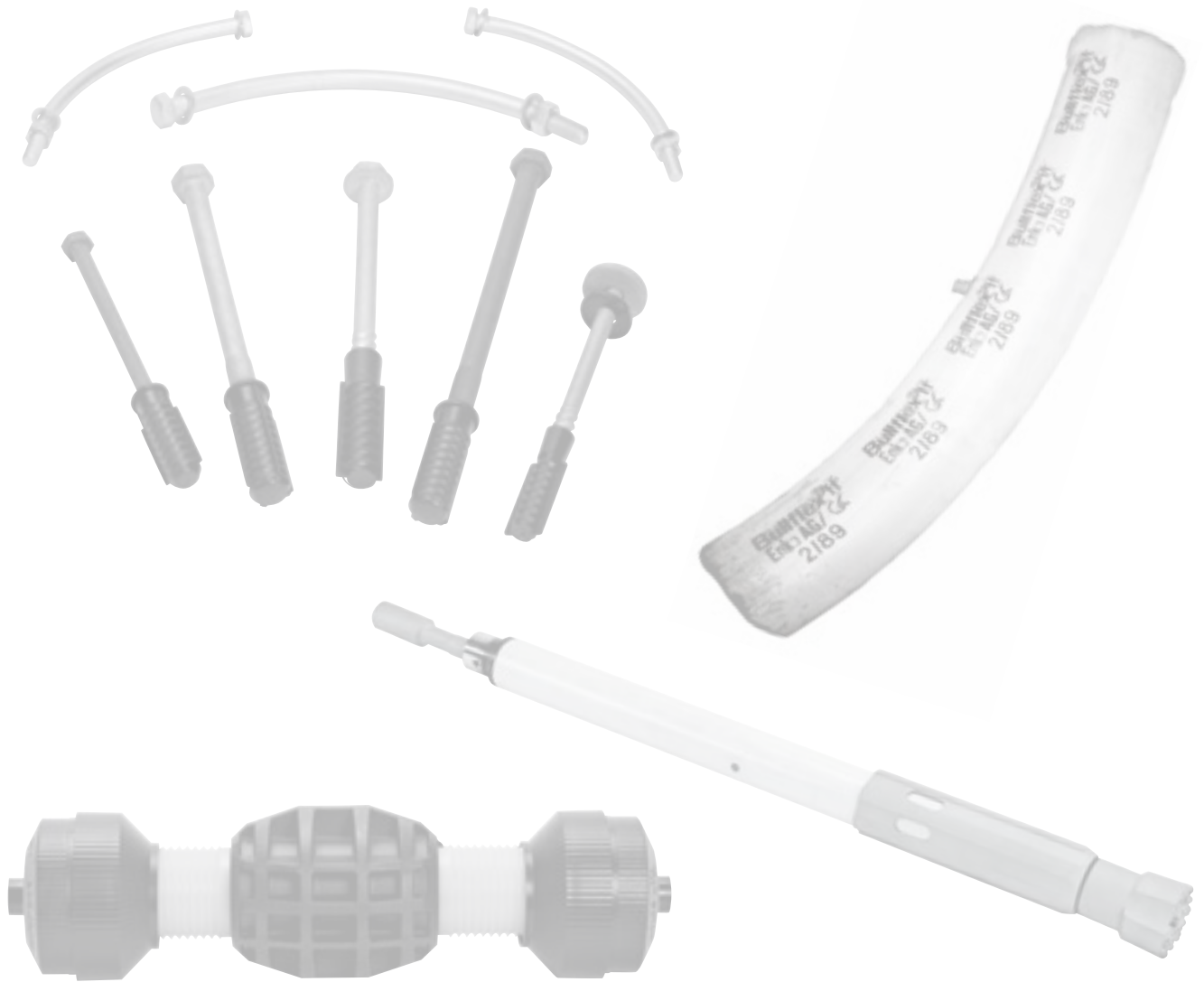

Segmental Lining Accessories

Bolting Systems

- Connection bolts for radial and circumferential joints
- Bolts and sockets in fast-thread spear and metric threaded versions
 - M12 to M30
- Straight or curved bolts
- Different diameters and lengths according to project requirements
- Various steel grades available
 - Grade 4.6 and 8.8 according to ISO 898-1
 - According to ASTM A307 or ASTM A325
 - Project-specific
- Self-color, galvanized, sheradized, or stainless steel versions
- Special designs available on request
- Steel and plastic washers
- Plastic, rubber, and hydrophilic grummets



DOWELOCK™ Connection and Alignment System

- Connection and alignment pin with two cast-in housings and collet assemblies
- Minimal insertion forces
- Three standard types
 - D30, D38, and D45
 - Each type can be supplied with three different shear load capabilities without dimensional changes
- Lowest extension figures under tensile load to maintain the integrity of the primary sealing system
- Optimum gasket alignment
- High resistance to external shear forces
- Pins without steel core for easy removal available on request



Segmental Lining Accessories

Grouting and Lifting Sockets

- Used for segment erection, primary, or secondary grouting
- Different dimensions according to project requirements
- Triple start and single start threads
- Closed or open ends
- Lifting socket with pull-out forces from 100 - 300 [kN] (22 - 67 [kip])
- Grout plugs with a pressure rating of up to 20 [bar] (290 [psij])
- Non-return valves prevent backflow of grout
- Hydrophilic sealings prevent water inflow between sockets and concrete segments
- End caps to prevent material ingress during the casting process
- Default length range: 80 - 220 [mm] (3.2 - 8.7 [in])
 - Standard sockets can be turned into any length by extension tubes



Accessories

- Segment packers for load distribution during construction
 - Bituminous felt, Tunpack™ polyethylene, hardboard, and plywood versions available
 - With or without self-adhesive backing
 - Dimensions according to project requirements
- Alignment dowels
- Guide rods
- Hole formers
- Segment spacers



Powered by



Available in selected regions



Introduction

BULLFLEX® structural sealings have been developed as a special solution for Underground excavation. The main application of this system are o-ring sealing systems used in combination with tunnel boring machines (TBM's).

BULLFLEX® structural sealings consist of patented textile groutable hoses made of high-strength fabric, which are subsequently filled with concrete, featuring an excellent sealing and load-bearing capacity.

The hoses are available in different dimensions, allowing an optimum alignment to the excavation dimensions or support perimeter. All system components are light-weight as well as easy to transport and install.

DSI Underground has long-time experience in the application of BULLFLEX® structural sealings. With the engineering and on-site support of DSI Underground, this system solution has been successfully used for various global infrastructure projects.

Main Advantages

- Quick and easy to install
- Pressure rating up to 4 [bar] (58 [psi])
- Easy compensation of eccentric and uneven excavation surfaces
- Application possible even in confined spaces
- Proven safety against failure of the sealing function in all working phases during passing-by of the TBM
- Special hose-in-hose system for TBM launching applications
- Easy handling on-site due to light-weight components
- Shrink free, UV resistant material
- High resistance against tearing; no longitudinal seams
- Inflation can be achieved using various filling media

System Description

The BULLFLEX® system provides an immediate load transfer and form fit between the passive support lining and the ground. Thanks to the special filter effect of the BULLFLEX® fabric, the surplus water in the grout fill is immediately drained, providing an accelerated curing procedure. Hence, the pressure inside the BULLFLEX® system is maintained, inducing an active pre-load into the excavation perimeter which leads to an immediate sealing action. The BULLFLEX® system can easily be adapted to on-site conditions using different diameters or filling media.

Due to the product characteristics of the BULLFLEX® textile, this system can be used for various different sealing applications. The endless, patented BULLFLEX® hose enhances the application as reliable and easy-to-use o-ring sealings for tunnel boring machines, featuring a special hose-in-hose system. The first BULLFLEX® hose seals the start and launching platforms of shield TBMs (sealing of the annular gap between sealholder and the TBM shield skin). Subsequently, the second BULLFLEX® hose secures the sealing between the excavation line and

segment ring. Further applications are so-called bedding hoses for flotation control of process tubes, or o-ring sealings for pipe jacking and structural repair works.

The use of BULLFLEX® structural sealing ensures the protection of machinery and civil structures against flushing media, compressed air, water, and building materials. Each BULLFLEX® structural sealing is customized for its application, backed up with extensive global experience and engineering solutions.



BULLFLEX® Structural Sealings

System Components

- BULLFLEX® groutable hoses
 - Patented endless round woven fabric
 - Default outer diameter range: 230 [mm] (9.1 [in]) to 800 [mm] (31.5 [in])
 - Off-size diameters and special designs are available on request
 - Permeable to air and water
 - Fabric made of polyamide 6.6
 - Anti-static, flame resistant, and self-extinguishing
 - Fabric which cools down the flames thanks to an endo-thermal reaction under the flame-point
 - Working pressure up to 4 [bar] (58 [psi])
 - Retention of the grout mineral content while draining due to the special filter effect of the BULLFLEX® system
- BULLFLEX® filling ports
 - With check valve
 - Inner diameter 32 [mm] (1¼ [in]) or 50 [mm] (2 [in])
- Fixing devices
 - Webbing
 - Hook-and-loop tapes
 - Clip systems
- Cement grout
 - Portland cement
 - High early strength

Principle BULLFLEX® O-Ring Sealing

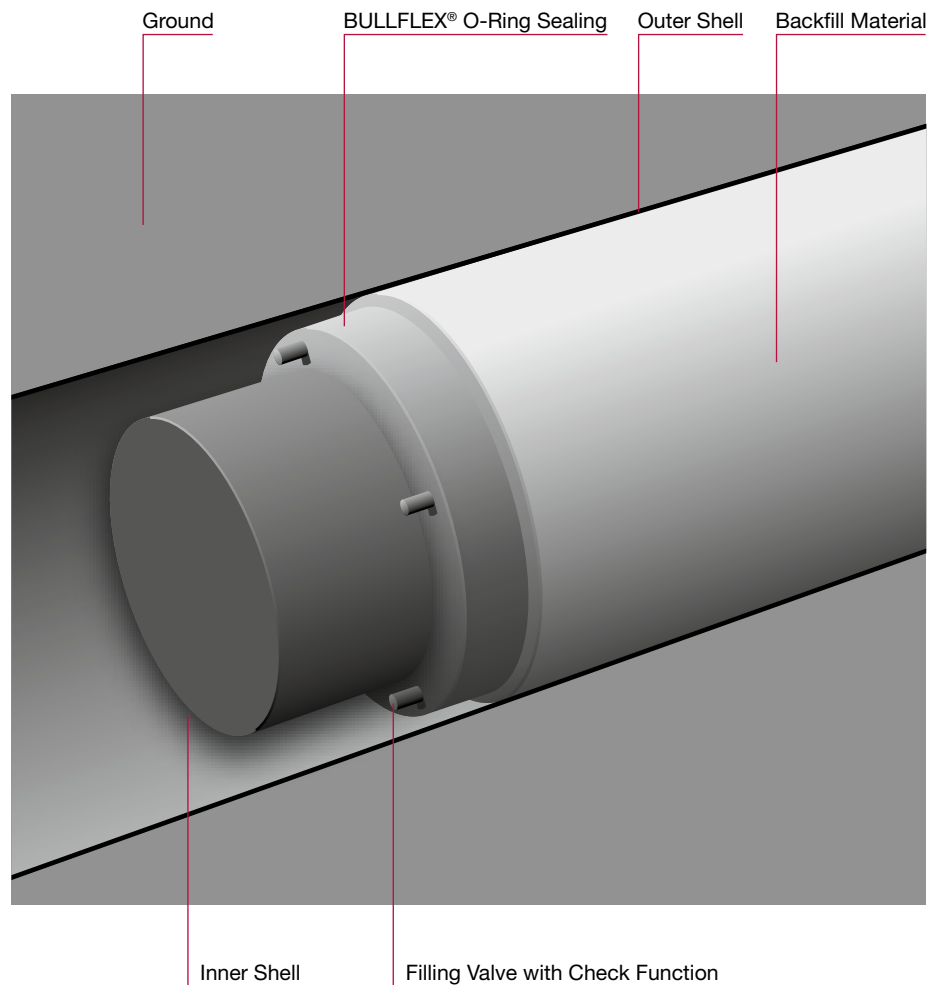

Specifications

Characteristics ¹⁾	Unit	Value	Remarks
Material	[-]	Polyamide 6.6	Nylon
Weight	[g/m ²] / [oz/yd ²]	Approx. 660 / 19.5	
Fabric thickness	[mm] / [in]	Approx. 1 / 0.04	
Minimum tensile strength	L ²⁾ T ³⁾ [N] / [lbf]	12,000 / 2,698 24,000 / 5,395	100 [mm] / 3.94 [in] width According to ISO 10319
Corresponding maximum elongation	L ²⁾ T ³⁾ [%]	20 20	According to ISO 10319
Elastic elongation	L ²⁾ T ³⁾ [%]	15 15	According to ISO 10319
Minimum seam strength	[kN/m] / [lbf/ft]	155 / 113	
Airflow through fabric at pressure [mbar] ([psi])	10 (0.15) 20 (0.30) 30 (0.45) [l/min] / [gal/min]	6.5 / 1.7 13 / 3.4 19 / 5.0	At 100 [cm ²] / 15.5 [in ²]
Residual tensile strength	[%]	20 - 30	After 1 year and under light exposure in Florida

1) The indicated values are laboratory values and may deviate on-site

2) Longitudinal

3) Transversal

Characteristics

Theoretical max. Pressure Resistance Depending on the Lining Gap and the BULLFLEX® Diameter

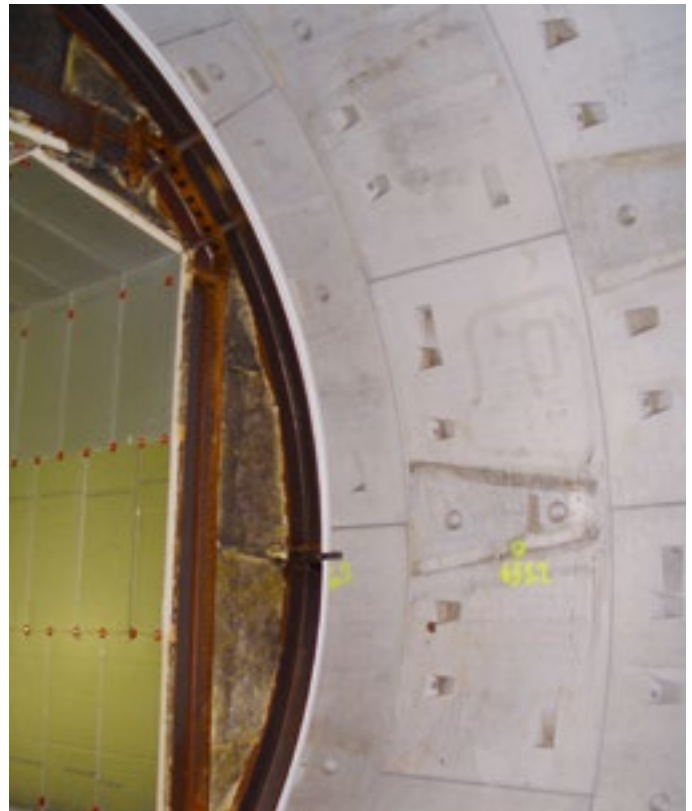
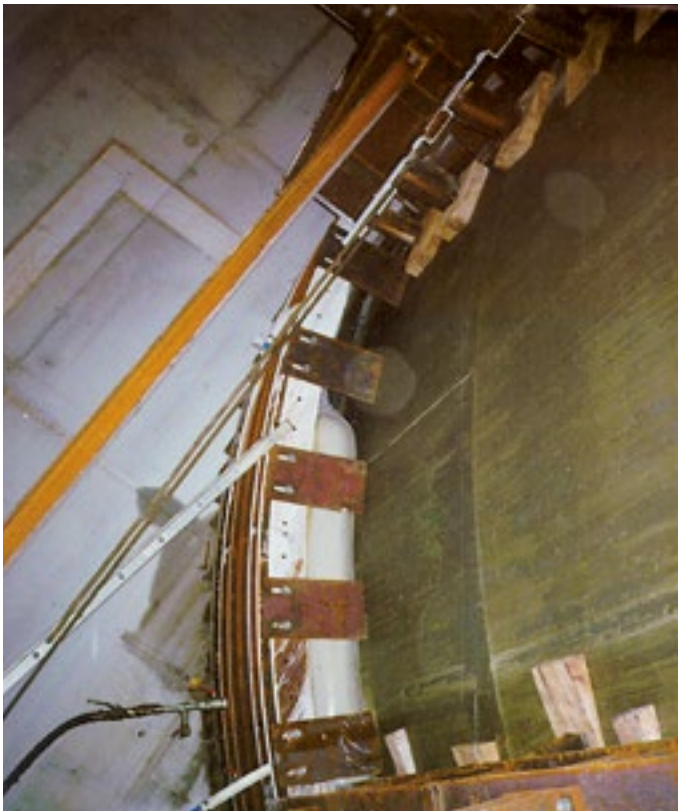
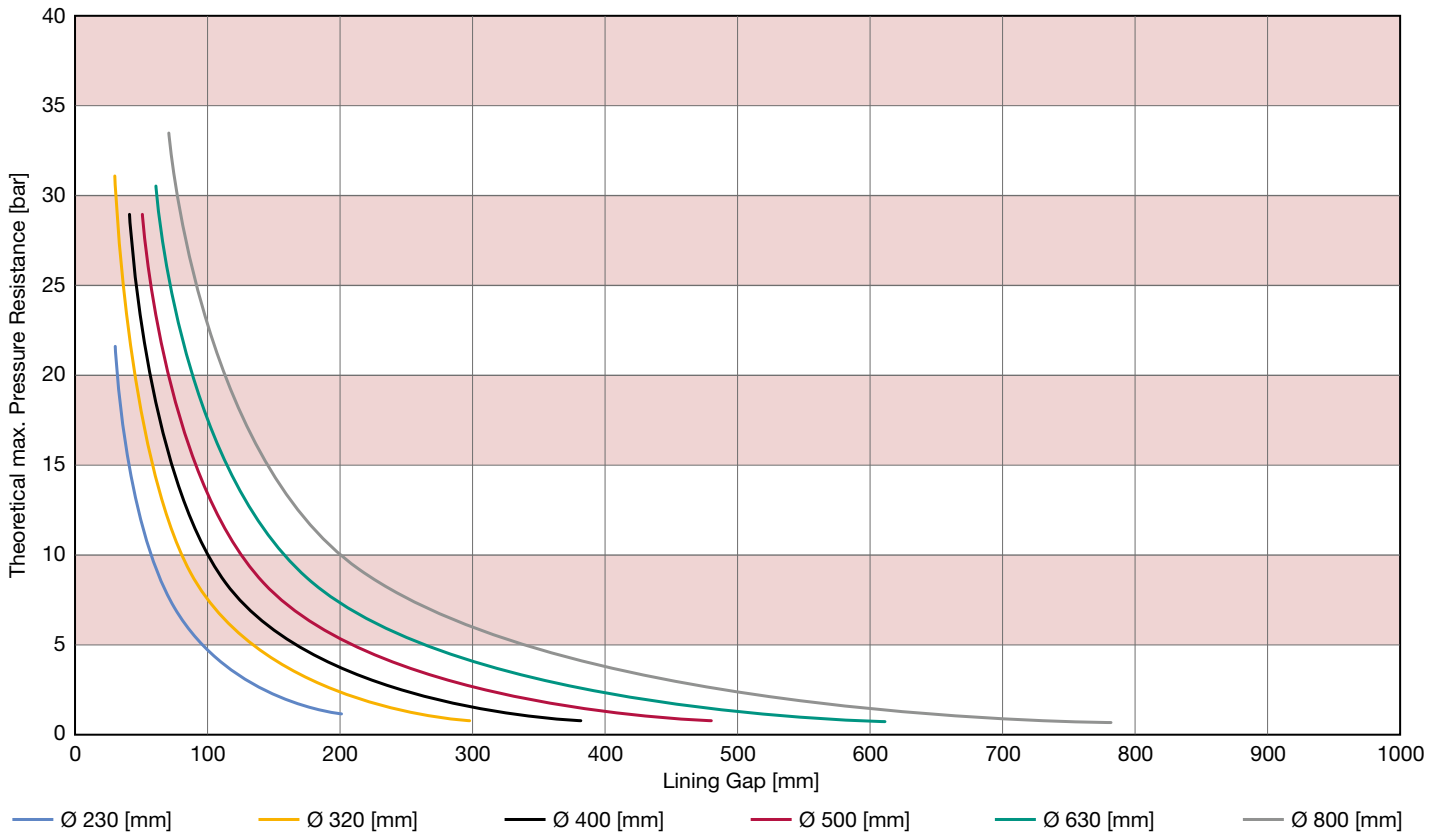

BULLFLEX® Structural Sealings

Installation Procedure O-Ring Sealing for Microtunneling



Mounting of the BULLFLEX® o-ring sealing for marking of the welding spots



Fixation of filling pipes into the BULLFLEX® filling valves
Note: to be able to ensure a proper grouting sequence, the filling pipes must be marked with different colors



Welding of screws to the sealing holder
Note: BULLFLEX® hoses must be protected against sparks and molten steel



Stepwise grouting process of the sections (filling ports)



Fixation of the BULLFLEX® o-ring sealing in the lower area



Increase of the filling pressure up to 4 [bar] (58 [psi]) to achieve active pre-loading

Note: during inflation (cement injection), all default and recommended personal protective equipment must be used. BULLFLEX® structural sealings are resistant against mine water inflow; the fabric itself is only soluble in concentrated inorganic acids and phenol.

TBM O-Ring Sealing Installation Procedure (Hose-In-Hose System)



- Mounting of two hose-in-hose BULLFLEX® o-ring sealings for marking of the welding spots
- Welding of screws to the sealing holder
Note: BULLFLEX® groutable hoses must be protected against sparks and molten steel
- Fixation of the BULLFLEX® o-ring sealing in the lower area
- Fixation of filling pipes into the BULLFLEX® filling valves
Note: it is required to mark the filling pipes with different colors (see above)
- Phase 1: stepwise grouting of the inner sections of the first and the second hose-in-hose BULLFLEX® o-ring sealings – sealing of the annular gap between the excavation line (sealholder) and the TBM shield skin
- TBM advance until the tail has reached the second BULLFLEX® o-ring sealing (view against driving direction)
- Phase 2: grouting of the outer hose section of the first BULLFLEX® o-ring sealing – sealing of the annulus between the TBM shield skin and segment ring
- TBM advance until the tail has passed the first BULLFLEX® o-ring sealing
- Phase 3: grouting of the outer hose section of the first BULLFLEX® o-ring sealing – now both BULLFLEX® o-rings proof the annulus between excavation line and segment ring

Note: in principle, the sealing will work with one single BULLFLEX® o-ring hose-in-hose assembly as well. However, based on previous experience, a redundant sealing system is recommended.



TBM O-Ring Sealing Installation Procedure (Hose-In-Hose System)

Principle of the Hose-In-Hose System

- Phase 1: 2 sealings close the annulus between TBM skin and the excavation line
- Phase 2: The TBM's tail is located under the second sealing. The outer hose of the first sealing has been filled and seals the annulus between inner lining and excavation line

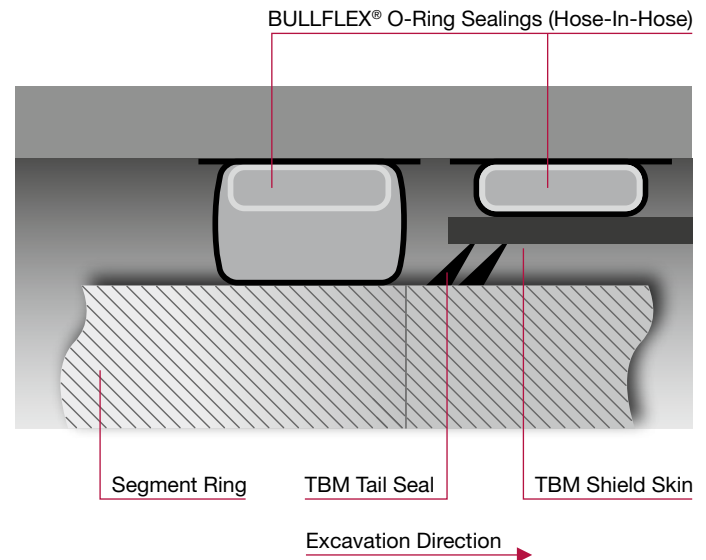
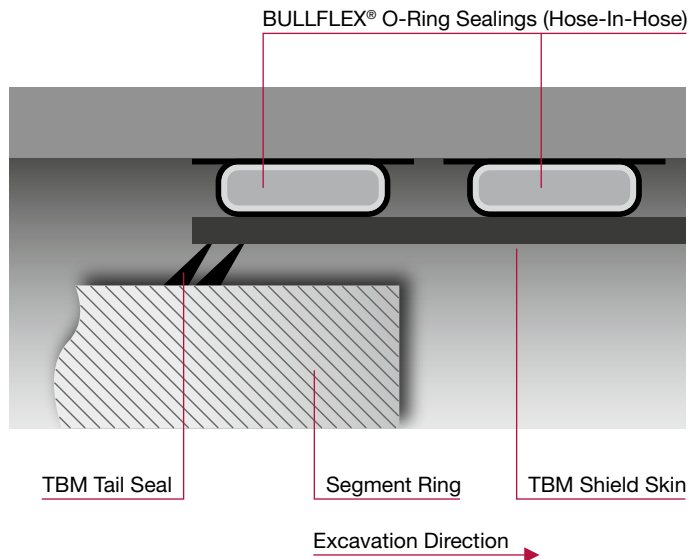

Recommendations for Installation

- Ensure that injection hoses are laid out without kinks
- Avoid contact with any sharp edges in order to prevent the fabric from being damaged
- Wherever there is a change of direction, the bending radius must not be less than six times the outside hose diameter
- Screw pumps are high-pressure pumps, therefore only steel-reinforced hoses may be used for grout transport
- Before starting the machine, ensure that easily workable grout is being used
- The intake hose must not leak anywhere (especially not at connections), and the inner side of the hoses must be sufficiently lubricated
- Before undoing the unions and the pump outlet flange, ensure that these components are de-pressurized by starting the main motor of the injection pump in REVERSE direction
- In order to prevent eye injuries, protective goggles must be worn, also when removing obstructions from the pump
- The person carrying out the task of pump operation must be at a safe distance from any material that may be discharged
- Accordingly, other people must be kept out of the immediate vicinity
- During inflation (cement injection), all default and recommended personal protective equipment must be used
- BULLFLEX® groutable hoses are resistant against tunnel water inflow; the fabric itself is only soluble in concentrated inorganic acids and phenol
- Further information is included in the BULLFLEX® material data sheet



BULLFLEX® Structural Sealings

Accessories

- BULLFLEX® filling nozzle
- Attachments for BULLFLEX® filling nozzles
- Flexible functional sealing inserts and protective inserts for the improvement of sealing capabilities
- Watertight inlets for up to 8 [bar] (116 [psi]) for emergency sealings and adjustment of existing sealings
- Steel-reinforced grout pumping hoses or grout pipes, minimum diameter: 51 [mm] (2 [in])
- Gunite pipes
- Valve extensions
- Repair kit
- DSI MAI® grout mixing pumps
- Other injection pump types are available on request



AT – GRP Injection System

Introduction

The AT – GRP Injection System is an AT-SYSTEM with glass fiber reinforced casing pipes (GRP), which is installed self-drilling. This system is mainly used when steel is not desired in the ground or where injection pipes are excavated by a TBM afterwards.

The injection pipes permit an insertion of any kind of ground influencing injection media into the ground. These injections may serve for ground improvement or waterproofing. The AT – GRP Injection System can thus be installed in jointed rock as well as in weak ground conditions.

Main Advantages

- Installation with standard drilling machines
- Drilling works can be executed by standard personnel under the supervision of application engineers
- Time-saving installation due to simultaneous drilling and tubing (self-drilling)
- GRP pipe length may be adapted to the space available
- GRP injection pipes can be cut and mucked out by a TBM cutting wheel



System Description

The AT – GRP Injection System is installed piecewise by rotary-percussive drilling with conventional drill booms.

The cooling of the drill bit and flushing of the cuttings take place inside the GRP tube.



AT – GRP Injection System

System Components

AT – Starter Unit with Drill Bit



AT – GRP Extension Tubes



AT – GRP Tail Casing Tube



Valves in Injection Holes



AT – GRP Drilling Adapter



AT – Adapter



Coupling Adapter and Drill Rods



Ready-For-Use AT – GRP Injection System



Specifications

- AT – 76 GRP; outer diameter 76 [mm] (3 [in]), wall thickness 8 [mm] (5/16 [in])
- GRP standard tube lengths: 1.0 / 2.0 / 3.0 [m] (3.3 / 6.6 / 9.8 [ft])

Technical Features

- The length of the AT – GRP Injection tubes can be easily adapted due to the piecewise installation
- Simple extension of GRP tubes even in confined working space
- High drilling accuracy during installation
- TBM drilling equipment may be used for installation

AT – GRP Injection System

Installation Procedure

1. The AT – Starter Unit with single-use drill bit is connected to the first AT – GRP Extension Tube. This part is then prepared on the drill boom together with the AT – Adapter and the drill rods.
2. Drilling of the first AT – GRP Extension Tube.
3. The next AT – GRP Extension Tube and the drill rod are connected with the previously installed part and are drilled subsequently.
4. Repeat the last step until the designed length including the AT – GRP Tail Casing Tube has been installed.

Accessories

- Injection flow-pressure meter
- Sleeve pipe packer
- Deep injection packer
- Grout mixing pump
- DYWI® Inject Systems
- Fishing tab
- Chain pipe wrench
- Drill rod wrench
- Centralizer
- Rock drilling equipment: shank adapter, coupling, and coupling adapter

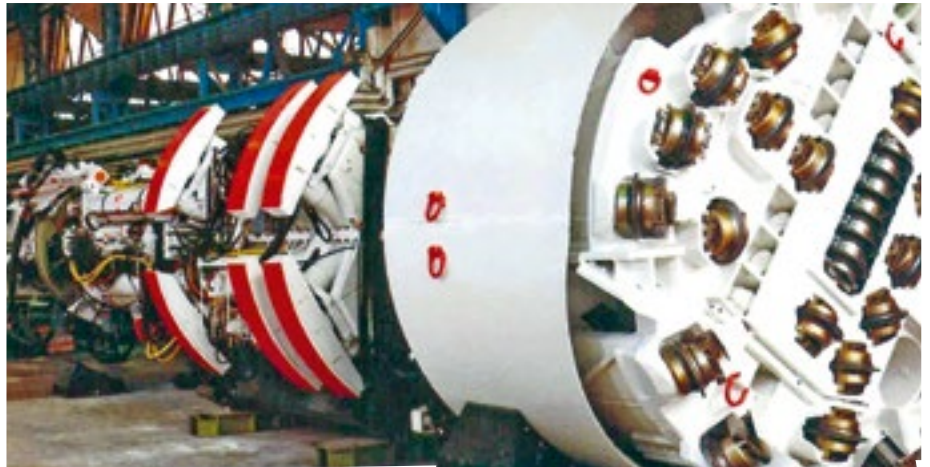

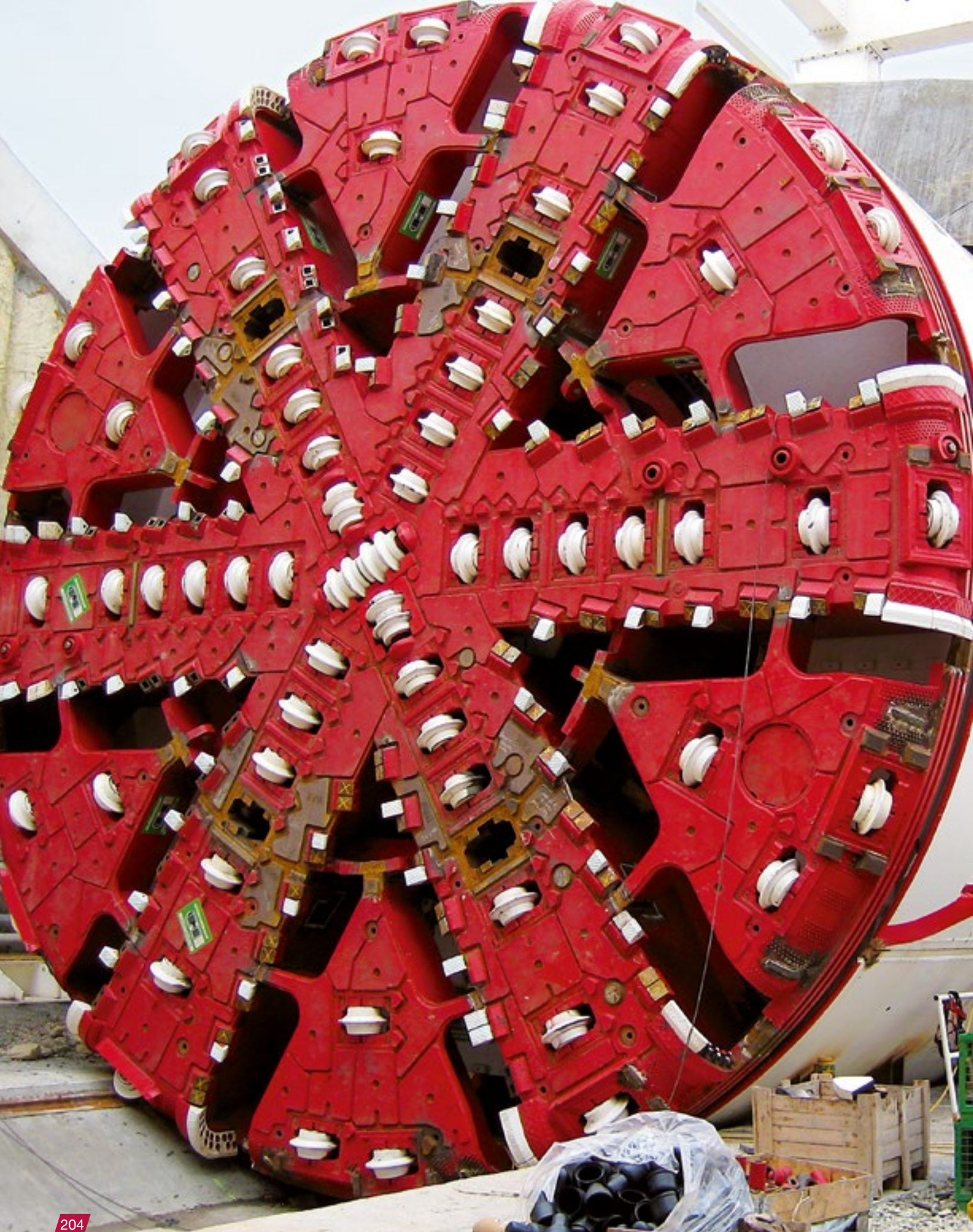







AT-B 407 895; PL-B 185 256; AT-B 411 781; AT-E 0 257 213; AT-B 412 739; AT-E 0 314 555;
CA-B 2 442 320; PL-B 197 261; RU-B 2278941; US-B 7 080 697; AT-E 0 332 436; ES 2262838 T5;
EP-B 1 381 756; TR 2006 03585 T4; AT-B 504 022; DE-C 101 05 827; AT-B 500 691; DE 101 19569;
HK 1066581; AT-U 8404; AT-B 501 875; AT-U 9287; AT-E 0 372 442; EP-B 1 682 745; AT-B 505 072;
AT-E 0 202 045; AT-U 10 289; AT-U 9597; AT-E 0 417 186; AT-E 0 514 836; EP-B 0 1 888 878;
AT-E 0 549 545; EP-B 1 886 056; AT-B 504 914; AT-B 505 158; AT-B 508 617; AT-U 12 096;
AT-U 12 097; AT-B 509 643; DE 10 2009 038 813; DE 10 2007 012 220; DE 10 2007 029548;
AT-U12444; EP-B 1 546 508; ES 2358738 T3; EP-B 1 546 508; TR 2011 02236 T4; EP-B 1 818 499;
AT-B 512 243; AT-E 614 034; EP-B 2 473 296; AT-U 13 162; AT-U 13 292; AT-E 705 881;
EP-B 2 556 205; AT-U 13 738; AT-U 14 223

Status: 2016-04

Austria

DSI Underground Austria GmbH
Alfred-Wagner-Strasse 1
4061 Pasching/Linz
Austria
Phone +43-7229-610 49 0
Fax +43-7229-610 49 80
E-mail office@dywidag-systems.at

USA

DSI Tunneling LLC
1774 Mellwood Avenue
Louisville, KY 40206-1756
USA
Phone +1-502-473 1010
Fax +1-502-473-0707
E-mail dsiunderground@dsiunderground.com



Please note:

This brochure serves basic information purposes only. Technical data and information provided herein shall be considered non-binding and may be subject to change without notice. We do not assume any liability for losses or damages attributed to the use of this technical data and any improper use of our products. Should you require further information on particular products, please do not hesitate to contact us.

"ALWAG" (AM 952/79, AM 3571/2008),
"AT" (AM 6138/2003), "AT-SYSTEM" (AM 6139/2003),
"DYWI" (4197869), "LSC" (AM 4326/2008),
"OMEGA-BOLT" (3258282), "POWER SET" (AM 6163/2002),
"ALWAGRIP" (AM 4327/2008), and
"TUBESPILE" (AM 4328/2008) are registered trademarks
of DSI Underground.

"Combi Coat" and "CT-Bolt" are trademarks of Vik Ørsta AS.
"BULLFLEX" is a trademark of BuM Beton- und Monierbau GmbH.
"MAI" is a trademark of MAI International GmbH.
DSI Underground is a partner of before-mentioned companies.

ARGENTINA
AUSTRALIA
AUSTRIA
BELGIUM
BOSNIA AND HERZEGOVINA
BRAZIL
CANADA
CHILE
CHINA
COLOMBIA
COSTA RICA
CROATIA
CZECH REPUBLIC
DENMARK
EGYPT
ESTONIA
FINLAND
FRANCE
GERMANY
GREECE
GUATEMALA
HONDURAS
HONG KONG
INDIA
INDONESIA
IRAN
ITALY
JAPAN
KOREA
LEBANON
LUXEMBOURG
MALAYSIA
MEXICO
NETHERLANDS
NIGERIA
NORWAY
OMAN
PANAMA
PARAGUAY
PERU
POLAND
PORTUGAL
QATAR
RUSSIA
SAUDI ARABIA
SINGAPORE
SOUTH AFRICA
SPAIN
SWEDEN
SWITZERLAND
TAIWAN
THAILAND
TURKEY
UNITED ARAB EMIRATES
UNITED KINGDOM
URUGUAY
USA
VENEZUELA

www.dywidag-systems.at
www.dsiunderground.com